

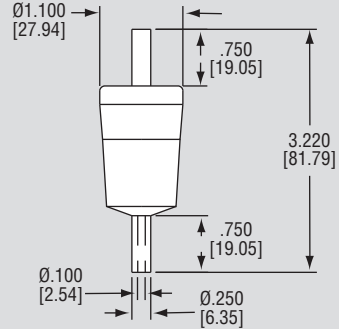

Model  
F195

# Disposable In-Line Filter

## Flowmeter Accessories and Options



Remove **99.99% of unwanted particles** from within your gas flow with the Model F195 Disposable In-Line Filter. Encapsulated microfiber filter elements are able to filter particles as small as 0.1 micron. Filters are completely disposable – simply remove the filter from your line and throw it away when it becomes dirty. The transparent nylon housing makes it simple to determine if the filter needs to be changed.

### Line Pressure vs. Flow

Line Pressure (psig)	1.5	10	20	30	40	60	80	100	125
Gas Flow (scfm)	0.6	0.9	1.3	1.6	2.0	2.7	3.5	4.2	5.7

\* 1.5 psi pressure drop.

### SPECIFICATIONS

**Filtration Efficiency:** 99.99% (removal of 0.1 micron particles).

**Housing Construction:** Nylon.

**Filter Tube Dimensions:** 0.59 ID x 1.39 L.

**Maximum Temperature:** 230°F @ 0 psig (110°C @ 0 bar), 120°F @ 125 psig (49°C @ 9 bar).

**Maximum Pressure:** 125 psig (8.6 bar).

**Maximum Differential Pressure:** 60 psi (4 bar) (in-to-out flow direction), 20 psi (1.4 bar) (out-to-in flow direction).

**Internal Volume:** 11.5 cc (11.5 ml).

**Connections:** Barbed for 1/4" ID tubing.

Model F195, Disposable In-Line Filter