

CARBON DIOXIDE/TEMPERATURE TRANSMITTERS

NDIR CO₂ Sensor, Universal Outputs, Optional Relay



North American style



Duct

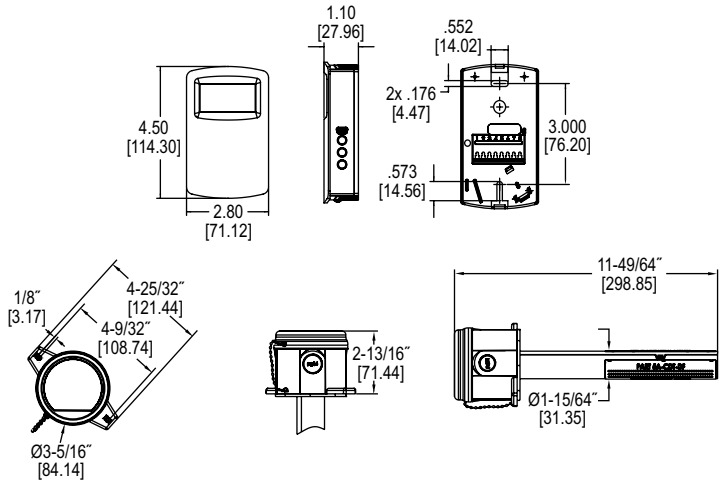

The **Series CDT Carbon Dioxide and Temperature Transmitters** accurately monitor the CO₂ concentration and temperature in indoor environments to help achieve energy savings. In order to achieve a higher level of accuracy, the Series CDT includes barometric pressure adjustment. The CO₂ universal output allows users to select the transmitter output to be 4-20 mA, 0-5 VDC, or 0-10 VDC to work with virtually any building management controller.

For applications that require visual indication, the wall mount configurations of the Series CDT can be ordered with an integral LCD display. To prevent tampering, the action of the buttons can be locked out using an internal dip switch selection.

BENEFITS/FEATURES

- Minimize inventory and save time by combining CO₂ and temperature measurements into one transmitter
- Reduces the number of devices mounted in the space with integral humidity and temperature sensors
- Requires minimal maintenance with Automatic Baseline Correction (ABC) to account for sensor drift
- Reduce operation costs using a low energy, reliable, and repeatable CO₂ sensor
- Simplify installation with backplate electrical connection

APPLICATIONS

- Demand control ventilation in schools, office buildings, hospitals, and other indoor environments
- LEED® certification

SPECIFICATIONS

Sensor: NDIR, 15 year life expectancy.

Range: CO₂: 0 to 2000 or 0 to 5000 PPM (depending on model); Temperature: 32 to 122°F (0 to 50°C).

Accuracy*: CO₂: ±40 PPM + 3% of reading (2000 PPM CO₂); ± 50 PPM + 5% of reading (5000 PPM CO₂); RH: ±2% (10 to 90% RH) (for units configured with humidity output); Temperature: ±1°C @ 25°C.

Response Time: 2 min for 90% step change.

Temperature Limits: 32 to 122°F (0 to 50°C).

Humidity Limits: 0 to 85% (non-condensing).

Power Requirements: 16-35 VDC or 19-28 VAC.

Power Consumption: Average: 2 w; Peak: 3.75 w.

Output: Current: 4-20 mA (max. 500 Ω); Voltage: 0-5 VDC or 0-10 VDC (min. 500 Ω); Relay: SPST NO rated 2A @ 30 VDC; RTD or thermistor per r-t curves on page 4 (depending on model).

Compliance: CE.

*The specified CO₂ accuracy is only guaranteed after three weeks of continuous operation in environments which are intermittently occupied.

MODEL CHART						
Example	CDT	-2	N	4	4	-LCD CDT-2N44-LCD
Series	CDT					Carbon dioxide/temperature transmitter
Range		2 5				0 to 2000 PPM CO ₂ range 0 to 5000 PPM CO ₂ range
Configuration			N D			North American style wall mount Duct mount
CO ₂				4		4-20 mA / 0 to (5 or 10) VDC
Temperature Output					0 4 A B C D E F	None 4-20 mA / 0 to (5 or 10) VDC 10 KΩ NTC thermistor type III 10 KΩ NTC thermistor type II 3 KΩ NTC thermistor Pt100 Ω RTD Pt1000 Ω RTD 20 KΩ NTC thermistor
Options					FC LCD RLY	Factory calibration certificate LCD display (wall only) Relay

ACCESSORIES	
Model	Description
A-449	Remote LCD display allows remote indication of select Dwyer® wall mount transmitters for validation or certification purposes
A-449A	Remote LCD display with buttons allows remote indication and calibration of select Dwyer® wall mount transmitters for validation and certification purposes



A-449