

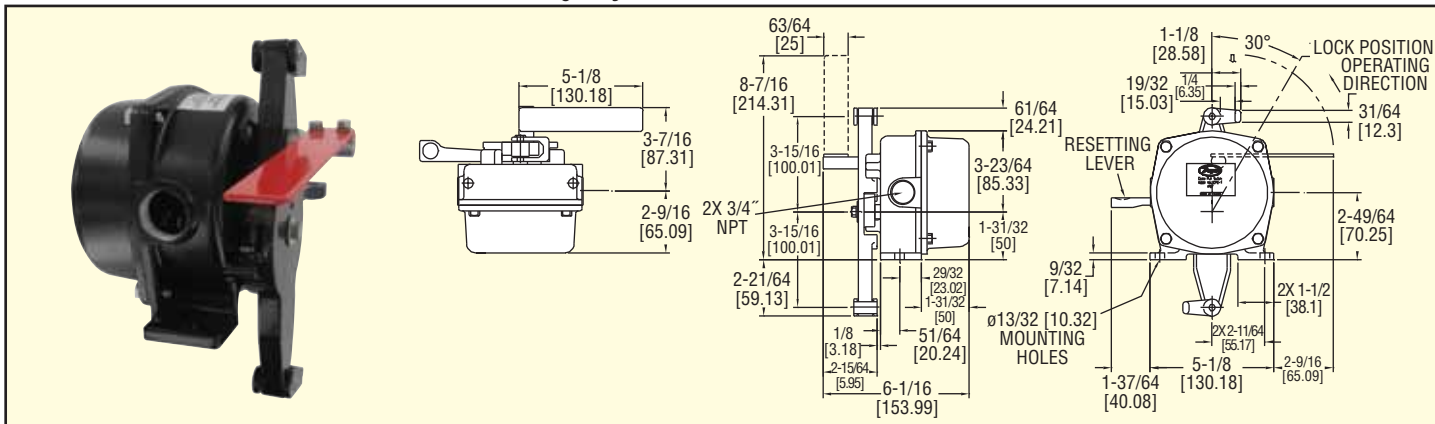

Model
CPS

Cable Pull Switch

For Emergency or Normal Shut-Off



The Model CPS Cable Pull Switch is designed to provide a switching system to isolate the power to the conveyor system or other similar process equipment in event of a shut-down condition. A steel wire is placed along the side of the conveyor and attached to the cable pull switch. When the cable is pulled at any point along the conveyor it will trip the cable pull switch causing the conveyor to shut down. To restart the conveyor the CPS must be manually reset. The CPS has a universal design for bi-directional activation and utilizes a highly visible red flag to indicate the switch status. The compact design makes it ideal for easy installation.

Model CPS-1, Cable Pull Switch

SPECIFICATIONS

Temperature Limits: -4 to 140°F (-20 to 60°C).

Enclosure: Die cast aluminum.

Enclosure Rating: NEMA 6 (IP67).

Switch Type: 2 SPDT.

Electrical Rating: 10 amp @ 125/250 VAC; 1/2 amp @ 125 VDC.

Electrical Connection: 3 screw type, common, normally open, normally closed.

Electrical Conduit: Two 3/4" female NPT.

Activation Angles: 30 degrees.

Activation Force: 11 ±2.25 lb. (5 ±1 kg).

Control Type: Manual reset.

Weight: 6.4 lb (2.9 kg).