

engineering and applications handbook

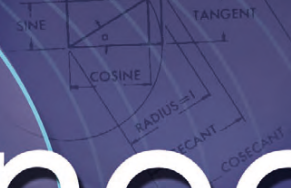
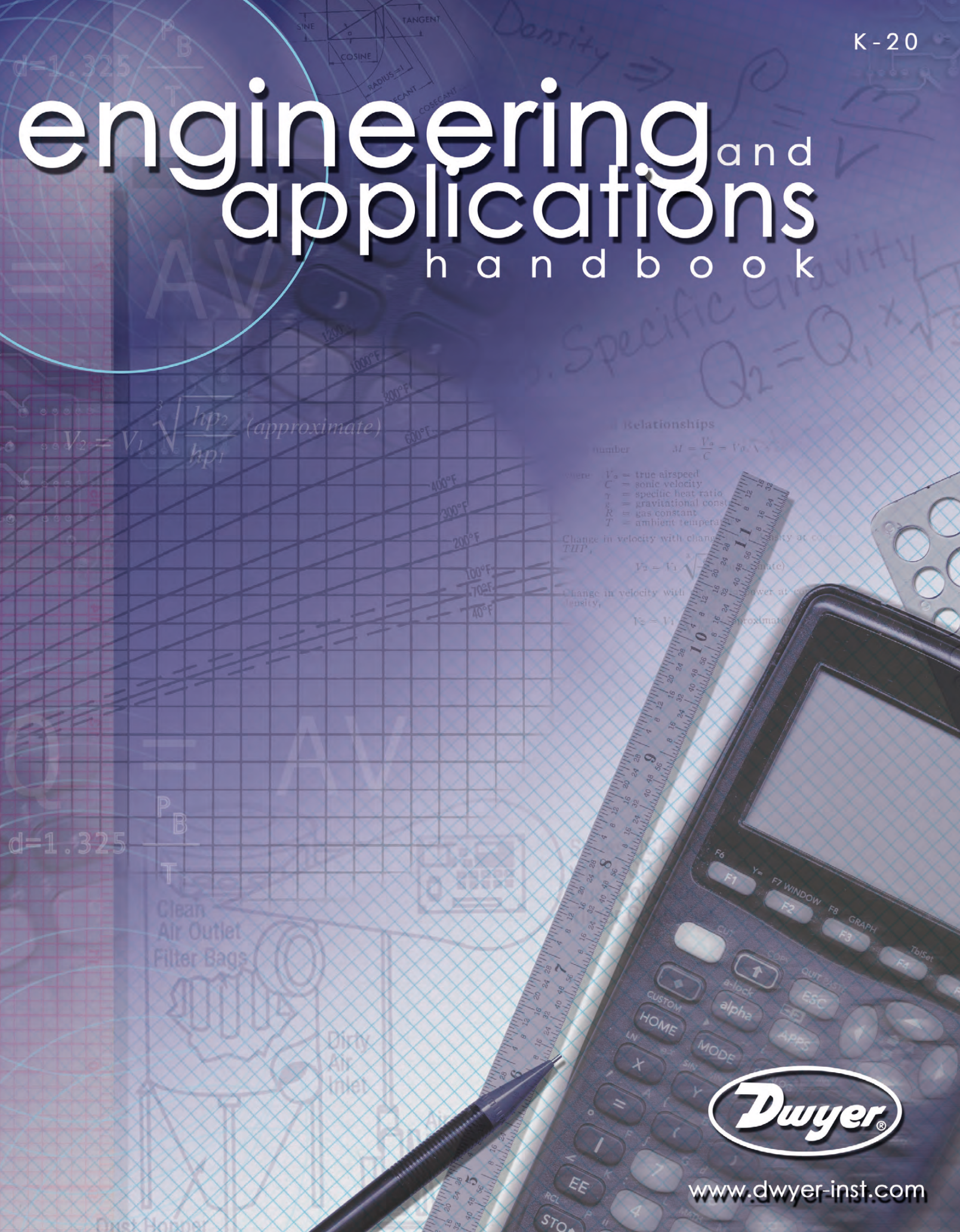

$d=1.325$

$v_2 = v_1 \sqrt{\frac{\rho_1}{\rho_2}}$ (approximate)

400°F
300°F
200°F
100°F
70°F
40°F

Relationships

Number $M = \frac{V_a}{C} = V_a \sqrt{\frac{\gamma}{RT}}$

- V_a = true airspeed
- C = sonic velocity
- γ = specific heat ratio
- R = gravitational constant
- T = gas constant
- T = ambient temperature

Change in velocity with change in density at constant temperature, TTP ,

$V_2 = V_1 \sqrt{\frac{\rho_1}{\rho_2}}$ (approximate)

Change in velocity with change in temperature at constant density,

$V_2 = V_1 \sqrt{\frac{T_2}{T_1}}$ (approximate)

$d=1.325$

P
B
T

Clean Air Outlet Filter Bags



Dirty Air Inlet



total instrument solution



Founded in 1931, Dwyer Instruments, Inc. produces a broad range of competitively priced precision instruments for measuring, transmitting and controlling pressure, temperature level, flow and related applications.

Many of these instruments are widely known by their individual brand names, such as Magnehelic® and Spirahelic® pressure gages, Photohelic® switch/gages, Rate-Master® and Visi-Float® flowmeters and Hi-Flow® valves. Divisions include well-known brand names such as Mercoid, W.E. Anderson, Proximity Controls and Love Controls.

Headquartered in Michigan City, Indiana, the company has four more Indiana manufacturing facilities, as well as manufacturing facilities in Anaheim, California; Fergus Falls, Minnesota; Kansas City, Missouri; and Naguabo, Puerto Rico.

In addition to making and selling quality precision instruments, Dwyer is committed to a standard of customer service – including competitive prices and knowledgeable, courteous technical support – that generates and sustains long-term relationships.

Customer Service

CUSTOMER SERVICE

Fast, friendly customer service professionals are available to process and provide assistance with your order – whether it is by phone, fax, e-mail or through our website.

Technical Support

TECHNICAL SUPPORT

Have an application question? Our technical support professionals are trained to provide you with the answers you need.

Prompt Shipments

PROMPT SHIPMENTS

After you place your order, Dwyer's dedicated shipping staff packs and ships your order promptly and completely – within 24 hours on most in-stock items.

WEBSITE

Dwyer Instrument's website delivers the convenience you want. Go to www.dwyer-inst.com for the most complete ordering and product support information at your fingertips – anytime, day or night. Installation and operating manuals are available on products that are easily downloadable to your computer or printer.

Total customer service the way you need it.



Dwyer Instruments, Inc.
accepts Visa® and
Mastercard®.

www.dwyer-inst.com

e-mail:
General: info@dwyer-inst.com
Literature: lit@dwyer-inst.com
Technical: tech@dwyer-inst.com
Quotes: quotes@dwyer-inst.com

website:
<http://www.dwyer-inst.com>
<http://www.love-controls.com>
<http://dwyer-inst.com/retail>
<http://proximitycontrols.com>

Address:
Dwyer Instruments, Inc.
102 Indiana Highway 212
P.O. Box 373
Michigan City, IN 46361 U.S.A.

Telephone:
(800) 872-9141
(219) 879-8000

Fax:
(219) 872-9057

introduction



Dwyer Instruments, Inc. Engineering and Applications Handbook

To help engineers solve design, manufacturing and physical plant problems, Dwyer Instruments, Inc. has developed this Engineering and Product Applications handbook. When such problems involve the measurement or control of gage or differential pressure, temperature, level or flow, chances are there is a Dwyer Instruments product that can provide the solution.

Reviewing the applications illustrated in this handbook may trigger an idea for a new approach to solving your engineering problems. For design engineers, these applications may also suggest ways to solve a customer problem and become the basis for a new product development.

The information contained in this handbook may also suggest a more reliable, convenient and lower cost approach when reworking an existing product or system design. In many cases the application suggestions may cut costs by increasing efficiency through continuous control of systems and processes.

The Engineering and Applications handbook also illustrates how engineers and technicians find applications for Dwyer controls and gages on a wide range of products serving a broad spectrum of industries and markets.

The Dwyer Instruments, Inc. full-line catalog and its websites deliver the convenience and assistance you want from an instrumentation company. Our catalogs are available to you free of charge via telephone, fax or websites. In addition, our websites contain installation and operating manuals on our products that are easily downloadable to your computer or printer.

Total customer service is our goal.

Index

Helpful Information 1 – 4

Glossary of Terms 4

Products from Dwyer 5 – 7

New Products 8

Pressure

Measurement 9 – 12

Control 12 – 24

Flow/Air Velocity

Air/Gas 24 – 33

Liquid 34 – 40

Level

Liquid 40 – 43, 45

Process 41

Control 43 – 45

Temperature

Control 45 – 49

Valves

Control 48 – 49

Process 50

Miscellaneous

Process 50

Analyze/Measure/Control 51

Reference 52

Important Note:

The gage and control hook-ups and sketches, and other application information shown in this Handbook are generalized and abbreviated to present the basic application idea only and no proprietary information has been revealed.

We believe this application information to be reliable, but is intended for use by persons, at their own discretion, having technical skill and knowledge of the business. Neither Dwyer

Instruments, Inc., nor the Mercoïd, Proximity, Love Controls or W.E. Anderson Divisions, shall be liable for loss, damage, or expense directly or indirectly arising from the use of any product described herein. In no event shall any of these Companies be liable for direct, indirect, special, or consequential damages. ©Copyright 2003 Dwyer Instruments, Inc. No part of this handbook may be reproduced in any form without the express written consent of Dwyer Instruments, Inc.

helpful information

Note these important design precautions:

As you start to design a new product or system that includes Dwyer Instruments components, you undoubtedly plan to achieve maximum performance, reliability and safety. A thorough knowledge of the characteristics of the Dwyer products included will help ensure the most successful result.

The following recommendations are based on years of field experience. They should prove invaluable to you in specifying the most suitable and efficient components for your application.

Pressure

The specified pressure ratings for Dwyer differential pressure gages, differential pressure switches, manometers, and flowmeters must be carefully observed. The Dwyer catalog lists options available for higher-than-standard pressure operation of the Dwyer Magnehelic® differential pressure gage and Photohelic® differential pressure switch/gage. In addition, small safety relief valves are available for these gages. The valves can be teed directly into the sensing line.

Pressure relief valves with adequate venting capacity should be used in any system if the supply is capable of delivering the air, gas, or other fluid at pressures greater than the system capability. If the system gas or fluid is noxious or toxic, be sure to dispose of this material properly by piping the pressure relief valve vent to a safe area.

When pressure regulators are used to reduce high-pressure air or gas for use in low-pressure systems, pressure relief valves should be installed on the low-pressure side of the regulator to protect the system in case of regulator failure or operator error. If pressure relief valves are not provided, pressure supply equipment should be selected with maximum pressure capability less than that which is safe for all components in the system.

Temperature

Because of the variety of elastomers and fluids used in Dwyer differential pressure controls and gages, specified operating temperature ranges for these products will vary. Pay particular attention to the temperature specification in the Dwyer catalog or installation and operating manual when you consider an application at high or low temperature. Options are available in some instances to provide for operation at lower than the specified minimum temperature, but such options may limit the ranges available and reduce the permissible maximum operating pressure.

If you specify manometers using water as the indicating fluid, take care to ensure that these manometers are never used in ambient temperatures below freezing. Call your nearest Dwyer sales office for information if you need special products and ratings to meet temperature and pressure conditions beyond the specifications of standard Dwyer products.

Electrical

To obtain maximum operating life, the electrical specifications for Dwyer controls and gages must be carefully observed. In order to provide specified performance, particularly in the low ranges, Dwyer differential pressure switches utilize a microswitch with a small contact gap and low spring rate to minimize operating force and movement. Because of the small contact gap, the maximum ratings are limited to resistive AC loads. The microswitch does not have a DC rating, as the gap can maintain a DC arc when the contact is broken under load even at very low currents.

However, AC arcing associated with resistive loads is self-extinguishing, as the voltage goes to zero at a rate equal to the line frequency. Inductive AC loads also require significant derating of the switch. This is due to the high voltage surge created when the circuit is broken, resulting in heavy momentary arcing which can destroy the switch contacts.

The best solution to control DC or inductive AC loads with Dwyer differential pressure switches is the use of an appropriate interface device, such as a mechanical relay or solid-state switching unit.

In "dry" circuit applications, where extremely low or no current flow is involved, specify the gold contact option for the microswitch to ensure reliable long-term operation.

Compatibility

It is important to ensure that the media coming in contact with a Dwyer control or gage be compatible with the materials of the wetted parts. This is necessary to prevent eventual failure of the control or gage or the contamination of the media itself. The various materials used as components of Dwyer controls and gages are specified in our catalogs. Various optional elastomers, metals, and plastics are available to meet specific customer requirements. In addition, special cleaning of all Dwyer controls and gages is required for oxygen service (except the Dwyer Photohelic® differential pressure switch/gage, which is not suitable for oxygen service).

We have data available on a wide range of media regarding compatibility with various stock or special products. Visit our website or call your Dwyer sales office for assistance in matters of material compatibility.

Reliability

Ideally, all pneumatic instrument systems should work with clean filtered air or gas which is non-toxic and dried to a dew point well below any ambient temperature in which the system will operate. Since this is not always practical, it is important to remember that, with few exceptions, air contains a substantial quantity of dirt and moisture. Over a period of time, the dirt accumulates until it plugs static tips, pitot tubes, sensing lines, even the gage and switch itself.

Changes in temperature in the sensing system, particularly in outdoor applications, may cause moisture in the system air or gas to condense. The accumulated water then creates problems in the gage, control, or sensing line. Such accumulations can produce corrosion, damage due to freezing, or simple blockage while in the liquid state.

Sensing and control systems are particularly susceptible to problems when operating in dust laden air, corrosive and wet media such as flue gases, and the moisture laden air associated with scrubbers and dryers. In the case of dust laden air or dirty liquids, sensing lines (and vented gage or control ports in ambient industrial conditions) should be equipped with filters having adequate surface area. The filters, as well as static tips or pitot tubes, should be inspected and cleaned frequently.

To protect against condensation, water separators, or drop legs should be installed in the sensing system at the low points where condensation will accumulate. The drop leg need only be made of a pipe section teed into the line and extending vertically downward from the desired location with a valve at the bottom to drain the water periodically. Using a large diameter pipe for the drop leg increases storage capacity and minimizes the number of times it must be drained.

Corrosive gases are often both dirty and moist. They may require both of the preceding precautions plus careful attention to compatibility with the wetted parts of the control or gage.

helpful information

It is most important to approach pneumatic systems design with the understanding that, despite careful design and safeguards, everything will eventually become dirty, wet, or corroded. Thus a good preventive maintenance plan is the key to maximum reliability.

Where the control or gage will be installed in a harsh environment, the added protection of a suitable housing is highly desirable. If a control or gage must be mounted outside, exposed to the elements, it should be protected as much as possible from direct exposure to the sun, rain, wind, heat, and cold. Weatherproof housings are available for most Dwyer controls and gages and certain models are inherently weather-proof.

A tropicalization treatment can be ordered for Dwyer differential pressure switches to be installed in hot, humid environments.

Although Dwyer sales personnel can advise you regarding materials compatibility and the proper application of Dwyer instruments and controls, system design is beyond the scope of their activities and the coverage of Dwyer's product liability insurance policy. For aspects of system design beyond the capability of the designer, we suggest retaining the services of a consulting engineer.

Safety

All of the above precautions are basic to the safe operation of any system employing pneumatic controls and gages. Particular emphasis should be placed on these precautions when systems are operating near the maximum rated pressure for the components, or when the gas or fluid in the system is noxious, toxic, or combustible, or where the system environment itself is hazardous due to explosive fumes or gases.

Dwyer offers various options and models to provide controls and gages capable of safe operation in an explosive environment. For example, you can order optional non-removable valve stems for Dwyer flowmeters to prevent the accidental release of pressurized or hazardous materials.

Before using combustible gases to operate Dwyer differential pressure gages, discuss your plan with a sales engineer. Potential compatibility and leakage problems may require a special modification for your application. These gages do not have built-in restrictors normally employed in combustible gas equipment.

Perhaps most important of all in designing a safe system is to realize that even the most reliable component, properly specified and installed, can and will fail eventually. Therefore, we recommend that systems be designed to fail-safe, i.e., the system will shut down or the process will stop if any critical component fails.

The system should be designed to anticipate failure due to loss of pneumatic pressure, loss of electrical power or any other possibility of failure related to the installation. Where positive operation is essential, back-up or redundant controls and power should be provided.

Performance

In general, differential pressure controls and gages will perform best when provided with the maximum differential pressure signal you can obtain in the application.

Higher-range gages and controls are generally less susceptible to problems related to vibration and shock, mounting position, temperature changes and accumulation of dirt and moisture. They are therefore easier to install and maintain. For example, when using a Dwyer

Magnehelic® gage as an air-flow monitor in a ventilation system, favor measuring total differential pressure across the blower versus sensing only static, velocity, or even total pressure on just one side or the other.

When it is necessary to repeatedly pressurize and depressurize a system, you can minimize or eliminate unwanted switch closures or annoying full-scale gage pointer deflection by placing suitable restrictors in the line on both sides or in some cases, only the low-volume side of the switch or gage.

When using Dwyer Magnehelic® differential pressure gages or Photohelic® differential pressure switch/gages in sensitive leak test systems, it is best to specify our "leak test option" when ordering the gage itself. This will reduce erroneous readings due to normal slight leakage in the instrument itself.

Although it is not possible to completely eliminate leakage in instruments with elastomer diaphragms, our special "leak test option" procedures and extra care will usually reduce the leakage to an acceptable level.

To minimize the potential for gage error due to a shift in the zero point reading, it is good practice to install two-way vent valves in both ports of a differential pressure gage. These valves permit closing off the sensing lines in an operating system while simultaneously venting both ports of the gage to the atmosphere to permit checking the zero setting or re-zeroing as necessary.

Your nearest Dwyer field sales engineer will be glad to review your application with you. He/she may help ensure maximum performance of the Dwyer control or gage specified.

Additional Design Precautions for Mercoïd Products

In general, the preceding design precautions also apply for Mercoïd pressure, temperature, and level controls. However, as Mercoïd products can be applied to a wider range of media under higher temperatures and pressures, often in more hostile environments, the following added design precautions should be considered.

As in any control application, the switch electrical specifications must be carefully observed. However, the availability of mercury switches in Mercoïd controls provides a unique advantage to the specifying engineer as they offer the capability for handling more demanding electrical loads than a snap-action switch. The mercury switch is preferred for higher alternating or direct currents, both in resistive and inductive loads.

In addition, the sealed mercury switch offers a level of inherent protection in hazardous conditions. It also provides excellent long-term reliability where control actuation is infrequent as the sealed switch configuration protects against contact corrosion which can cause other types of switches to malfunction.

Mercury switches are also ideal for low-voltage and low-current (dry contact) circuits such as encountered in computer controlled applications. However, the design engineer should give consideration to concerns about potential mercury contamination in switch applications where this may be a factor.

In applying Mercoïd Bourdon tube pressure switches, the use of a surge tank, snubber and/or capillary tubing connection is recommended where pulsation or pressure surge cannot be avoided. Additional protection against vibration and pulsation can be obtained by specifying the Delrin bushed movement option.

Additional Design Precautions continued on next page

helpful information

Additional Design Precautions for Mercoird Products, continued

For steam service of 35 psig or higher, or high temperature media, a siphon or remote connection is recommended to ensure that the ambient temperature rating of the switch is not exceeded.

When applying a Mercoird Bourdon tube pressure switch with flammable, hazardous or toxic gases or liquids, a stainless steel Bourdon tube control should be specified as the welded Bourdon tube will reduce chances of leakage in case of fire. For applications with any chloride media, the use of a 316SS Bourdon tube pressure switch is also recommended. For additional protection, a diaphragm seal can be specified to prevent corrosive, viscous or other damaging media from entering the Bourdon tube in the control.

An over pressure diaphragm should be specified where the normal system working pressure is low but pressure may occasionally rise above the range of the control to as high as 5000 psig. The over pressure seal is designed to protect the control if pressure increases beyond a predetermined point. When a set range is exceeded, the diaphragm seats and no further motion is allowed, effectively limiting transmitted pressure.

As with all instrumentation, care should be taken to avoid freezing of the media in the pressure element to prevent operating failure and damage to the control.

In applying bulb and capillary temperature controls, specifying a protective well for the bulb may be advisable. The well will permit removal of the control from the system without the problem of escaping media or the need to shut down the system. In addition, the well may provide required media compatibility. However, protective wells do increase the response time of the temperature control, a factor to be considered in their specification.

Level controls with cast iron housings should not be specified for use with flammable, explosive or toxic media. In the intense heat of a fire, cast iron housings can crack and release the media.

Where a liquid level control must function reliably under conditions of extreme vibration, a special anti-vibration mechanism is available and should be specified.

Specifying engineers should obtain a free copy of the Mercoird Catalog, Bulletin E-60-M, a technical guide to the selection and application of Mercoird DA Series temperature and pressure controls.

Finally, consult the factory or Dwyer field sales engineer if you have any questions regarding the application of Mercoird products.

Glossary of Terms

Absolute Pressure (psia) – The total force per unit area exerted by a fluid. The sum of atmospheric and gage pressures.

Alternating Current (AC) – Current that reverses polarity at a uniform frequency.

Atmospheric Pressure – The force exerted per unit area by the weight of the atmosphere.

Cavitation – Process in which small bubbles are formed and implode violently.

Contacts – Elements used to mechanically make or break an electric circuit.

C_v or Valve Flow Coefficient – The number of US gallons per minute of water at 60°F that will pass through the valve with a pressure drop of 1 psi.

Direct Current (DC) – A current with a constant polarity.

Double Pole Double Throw (DPDT) Switch – Two separate switches that operate simultaneously, each with a normally open and a normally closed contact and a common connection.

Gage Pressure (psig) – The measure of force per area exerted by a fluid using atmospheric pressure as the zero reference.

Humidity – The amount of moisture in the air.

Impedance – The opposition in an electric circuit to the flow of an alternating current consisting of inductive reactance, ohmic resistance and capacitive reactance.

Maximum Surge Pressure – Safe pressure for the switch housing but which may damage the mechanism by continuous or repetitive application.

Normally Closed Switch – A switch in which the contacts are normally closed. Actuation opens the contact.

Normally Open Switch – A switch in which the contacts are normally open. Actuation closes the contacts.

NPT – National Pipe Thread.

Null Switch – A floating contact switch with a zone of no contact. Often used to operate reversible motors.

pH – An indication of the acidity or alkalinity of a solution in units ranging from 0 (most acidic), to 7 (neutral), to 14 (most alkaline).

Pressure Drop – The difference in upstream and downstream pressure of the fluid flowing through a valve.

Range – The span of differential pressures or flow rates within which the sensing element of a given switch can be set to actuate an electric switch.

Rated Pressure – The maximum pressure that the actuating components of the switch in contact with the media can withstand continuously and/or repeatedly without risk of permanent damage.

Relative Humidity – The ratio of the quantity of water vapor in the air to the quantity of water vapor required for saturation at the same temperature.

Repetitive Accuracy – The ability of a pressure or flow switch to operate repetitively at its set point under consistent conditions.

Saturation Point – The point at which condensation is formed.

Serial Transmission – Sending one bit at a time on a single transmission line.

Set or Actuation Point – The exact air pressure or flow rate which will cause the electric switch to actuate.

Single Pole Double Throw (SPDT) Switch – A switch combining both normally open and normally closed switch contacts.

Solid State – Any element that controls current without moving parts, vacuum gaps or heated filaments.

Temperature Compensation – The correction for the influence of temperature on a measurement.

Transducer – Any device that generates an electrical signal from physical measurements.

Transmitter – A device that translates the low-level output of a sensor or transducer to a higher level signal suitable for transmission to a site where it can be further processed.

Viscosity – The resistance of a fluid to flow when subjected to shear stress.

products from Dwyer



Magnehelic® differential pressure gage



Capsuhelic® differential pressure gage



Photohelic® pressure switch/gage



Capsu-Photohelic® pressure switch/gage



Minihelic® II differential pressure gage



Mini-Photohelic® differential pressure switch/gage

Differential Pressure Gages and Switch/Gages

All Dwyer dial-type differential pressure gages employ the Magnehelic magnetic linkage principle to measure differential pressures from 0.25" Water Column (w.c.) to 30 psig in total pressure environments up to 500 psig. This family of gages provides a direct indication of differential pressure on easy-to-read 4" dials (Magnehelic®, Capsuhelic®, Photohelic®, and Capsu-Photohelic® gages) and 2-1/2" dials (Minihelic®, Mini-Photohelic® gages) utilizing a reliable, shockproof, diaphragm actuated mechanism that provides a low-cost gage with high performance. While primarily applied in the measurement of low differential pressure in air and gases, Dwyer Capsuhelic® differential pressure gages are suitable for use with compatible liquids. Standard Capsuhelic® differential pressure gages and Capsu-Photohelic® switch/gages have aluminum bodies; brass bodies are available and are required for water service. New Mini-Photohelic® differential pressure switch/gage combines the time proven Minihelic® II differential pressure gage with two SPDT switching setpoints.

The Dwyer Photohelic® and Capsu-Photohelic® series of differential pressure switch/gages add phototransistor actuated relays with easily adjusted set points to provide low and high limit electrical control in addition to the measurement of differential pressure. All of these gages are commonly employed to measure and control pressure, velocity, or flow in stacks, air conditioning systems and clean rooms, to monitor furnace draft, to indicate pressure drops across orifice plates or venturi tubes, and to measure liquid levels with bubbler systems, fume hood exhaust velocities, blood or respiratory pressure in medical equipment, cooling air pressure in electronic equipment enclosures, etc.



Model 424 Durablock® Inclined-Vertical



Mark II



Series 490 wet/wet handheld digital manometer



Model 1211 Slack-Tube® roll-up



Series 475 Mark III handheld digital manometer



Series 1223 Flex-Tube® U-tube

Manometers

Dwyer manufactures a wide variety of virtually unbreakable plastic manometers. Both portable and stationary manometers of the U-tube, well-type, inclined and inclined-vertical types provide for the measurement of low range air pressures, pressure differentials and vacuum. Several models of Flex-Tube®, U-tube and Slack-Tube® (roll-up) manometers provide high accuracy at low cost for field work. Mark II molded styrene-acrylonitrile plastic models serve minimum-cost industrial applications. Durablock® solid acrylic machined manometers function as standard references in the laboratory and for field work as well. New handheld digital manometers offer convenience and accuracy in compact, portable units.



Series 7100 Spirahelic® gage



Series 7000B Spirahelic® gage



Series DPG digital pressure gage

Series 64000 Stainless Steel Pressure Gage



Series 62000 Pressure Gage



Pressure Gages

Dwyer Spirahelic® gages incorporate spirally and/or helically wound Bourdon tubes. All feature solid-front design with a simple, reliable direct drive mechanism. Models are available in ranges from 0-30 to 0-10,000 psig and metric equivalents in kPa, MPa and Bar. Units are available in both turret and panel mounts, digital displays, NEMA 4X housing, and accuracies up to $\pm 0.25\%$ of full scale, ASME Grade A, 2A & 3A. Special Test Gages feature a precision knife edge pointer, finer minor divisions and a mirrored band to prevent parallax error.

For digital indication, the Series DPG offers exceptional accuracy ($\pm 0.25\%$ of full scale) in a NEMA 4X housing. The DPG is battery-powered, has a 4-digit display to reduce reading errors, and is an economical replacement for outdated analog gages.

Other pressure gages available include the Series 62000 and 64000. The Series 62000 is an extremely versatile, low cost gage that offers a dual scale in psi and kPa, with ranges up to 300 psig (2100 kPa) and selectable back or bottom mounting positions. The Series 64000 stainless steel pressure gage is ideal for applications involving pressure spikes, vibrations and pulsations, and delivers accurate readings in the harshest environments.

products from Dwyer

Model 1638

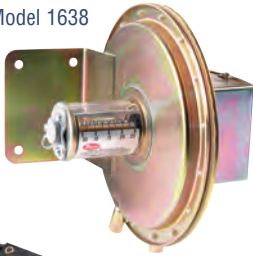

Model H3



Model 1950 explosion-proof



Series MDA Pressure Switch



Series MDS Pressure Switch



Model 1910



Model 1823



Differential Pressure Switches

Dwyer offers a wide range of differential pressure switches, including explosion-proof models, which are precision diaphragm operated and which can be actuated by positive, negative or differential pressures. Designed for low and very low pressure differential, ranges from .03" w.c. to 200 psid are available. These switches are most commonly used to control or prove air flow in air conditioning, refrigeration, ventilating and combustion systems. The W.E. Anderson® Model H3 Explosion-proof differential pressure switch serves process applications requiring higher ranges and operating pressures and/or aggressive gas or liquid media. Series MDA & MDS miniature pressure switches are perfect for low pressure control. The MDS has a double diaphragm design to protect against false actuation due to shock or vibration, and the MDA has a field adjustable setpoint.



Series 605 Indicating transmitter



Series 607 transmitter



Series 616C transmitter



Series 645 Wet/Wet differential transmitter



Series 604A transmitter

Differential Pressure Transmitters

The Dwyer 605 Differential Pressure Transmitter combines state of the art sensor technology with the proven design of the Magnehelic® gage. The transmitter provides a standard 4-20 mA analog signal output in ranges as low as 0.1" w.c. to 200 psid and 0-3" w.c. to 0-100 psid for the Series 616C transmitter and is accurate within $\pm 2\%$ in normal ambient temperatures. The Series 616C features exceptional $\pm 1\%$ accuracy. Applications include controlling of variable-speed fans, blowers and positioning of system dampers. Supplies data on air velocities in ducts and pressure drops across air filters. In the medical field it can interface with a computer to provide blood and respiratory pressure data. Series 607 is ideal for reliability in critical applications where 0.25% accuracy is required. It is designed to resist shock and vibration while maintaining an accuracy of $\pm 0.5\%$. The Series 645 is designed especially for liquid and air applications and has an amazing accuracy of $\pm 0.25\%$. It is available in bi-directional ranges and optional 3 valve manifold.



Model H-2 Duotect® pressure switch



Series A1PS/A1VS pressure switch



Mercoird® 1000 Series pressure switch



Series APS/AVS adjustable pressure switch



Mercoird® DA Series pressure switch

Pressure Switches

The Mercoird® Division of Dwyer Instruments, Inc. manufactures a broad line of Bourdon tube and diaphragm operated pressure switches, most models offering either mercury or snap action electrical switches and adjustable deadbands. Ranges to 8000 psig are available with explosion-proof or weatherproof options. The Mercoird DA Series with optional mercury switches are well-known for their long term reliability and resistance to contact corrosion. They are ideal for both high and very low direct current applications. For use in liquid and gas applications.

W.E. Anderson® manufactures the unique dual pressure Duotect® explosion-proof pressure switch with one diaphragm actuating two snap switches. The switches operate independently of each other and can be adjusted to settings of up to 1500 psig.

Series A1PS/A1VS are economical pressure switches that provide field adjustable control and are available in vacuum, pressure or compound ranges. The Series APS/AVS provides reliable switching for pressure/vacuum alarms.

Flow Switches



Model V4-2-U Flotect® flow switch



Model V10 Flotect® mini-size flow switch



Model V-6 Flotect® flow switch



Series P5 shuttle flow switch

The W.E. Anderson® Division of Dwyer Instruments, Inc. provides a line of Flotect® vane operated flow switches for installation in pipelines or ducts to protect equipment against excess flow, low flow, or stoppage of liquids, gases, or slurries.

Explosion-proof construction is standard for most of these switches. They can be installed in pipes with diameters from 1/2" up to 20" or more.

Other models such as the Model V10 are ideal for compact, cost effective requirements. The P5 PVC shuttle flow switch is designed with one moving part for long life and minimum maintenance.



Series SFI 800 sight flow indicator/transmitter



Model 300 sight flow indicator



Model 360F flanged sight flow indicator



Series GFC gas mass flow controllers/meters

Sight Flow Indicators & Transmitters

For liquid flow, the W.E. Anderson® Division manufactures a broad line of spinner, flapper, rotor and see-through sight flow indicators for pipe sizes from 1/4" to 4" in bronze, stainless steel and polysulfone housings. Dwyer Series GFC gas mass flow controller is a versatile solution to applications where strict flow metering and controlling are imperative. Field selectable 0-5V or 4-20mA linear output is standard.

products from Dwyer

Below, left to right:
Rate-Master®
Models RMC,
RMB, & RMA



Below, left to right:
Visi-Float®
Models VFCII,
VFB, & VFA



Below, left to right:
Series DR direct reading
glass flowmeter;
Series VA Teflon®/
glass flowmeter



Right:
Series UV
Ultra-View™
polysulfone
flowmeter



Flowmeters

Dwyer flowmeters are used in a multitude of applications in industrial, commercial, scientific and medical equipment where the flow of air, water, oil, or compatible gases or chemicals must be monitored or controlled. Dwyer offers a multitude of variable area flowmeters for these applications. Three sizes are offered in the extremely popular Rate-Master® series. Manufactured from durable molded polycarbonate, choose from the many available ranges in air (0.1 to 1800 SCFH) or water (1 GPH to 8 GPM). Dwyer's Visi-Float® flowmeter series, manufactured from machined acrylic, are available in three body sizes and many ranges – 0.1 SCFH to 100 SCFM of air and 0.6 GPH to 20 GPM of water. The latest edition to Dwyer's variable area flow meter family is the Series UV Ultra-View™. Highly engineered, the Series UV flow meter is made of Polysulfone and does not contain any metal wetted parts, making the Series UV perfect for applications involving ultra-pure water. Units are extremely accurate and can withstand 100 PSI (10.3 bar) pressure at 212°F (100°C). Dwyer's VA glass flowmeters offer superb precision and control. Materials of construction and universal scales offer the ideal flexibility when measuring different gases and liquids. The Series DR direct reading flowmeters give users the overall advantage of glass flowmeters while displaying flow rates on a direct read scale.



Series L10
Flotect® mini-size
level switch

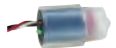

Model OLS-
12 optical
level switch



Series F7 level
switches-vertical



Mercoid
Series
190
displacer
type level
control



Series L8 Flotect®
liquid level switch



Anderson Model
L-4 level switch

Level Controls

Level controls from the Mercoid® Division cover a broad range of applications in the process, refining and utility industries. Chamber type level controls are available with operating pressure ratings to 2300 psig. The Series 190 displacer type control features adjustable level setpoints and is ideal for industrial sumps. Other models available for boiler water level control. Most Mercoid® level controls are available with either mercury or snap action switches. Explosion-proof float switches with wetted parts of brass or stainless steel are available from W.E. Anderson® Division to monitor liquid levels in tanks. Explosion-proof float switches with wetted parts of brass or stainless steel are available from W.E. Anderson® Division to monitor liquid levels in tanks. The L-8 Level Switch features a leak proof body and optional weatherproof enclosure; Series L10 Level Switch installs easily in-wall or externally and accommodates liquids with low specific gravities.



Mark II
Inclined-vertical



Model 250.5
Durablock®
inclined manometer



Dial type Magnehelic®
air filter gage

Air Filter Gages

The Magnehelic® dial-type differential pressure gages and the manometers described above are also offered as complete air filter gage kits to measure resistance of air flow to indicate whether a filter is clean or dirty. The kits are provided complete and ready to install, including static pressure pick up tips and connecting tubing. The Capsuhelic® gage is suitable for measuring differential pressure across many liquid filters.



Series 475-1T-
FM-AV air
velocity kit



Model 400-10
air velocity meter

Model VT-200
vane thermo-
anemometer



Model 471-3 digital
thermo-anemometer

Air Velocity Instruments

Dwyer differential pressure gages and manometers are offered individually and as complete air velocity measuring instrument kits. Supplied with gage, Pitot tubes and connecting tubing, this group includes a wide variety of types and price ranges from exacting laboratory needs as well as plant or field use. These gages are calibrated to read air velocity directly in feet per minute as well as static and velocity pressure in inches of water column. Pitot tubes are offered in numerous models. The Series 641 Air Velocity Transmitter delivers precise readings in ranges to 15,000 FPM or 75 MPS and has an optional LED read-out. The VT-200 vane thermo-anemometer is the ideal instrument for HVAC applications, measuring air volume, air velocity and temperature and storing up to 1000 measurements with built-in datalogging capabilities.



Series TS digital
temperature
switch

Series M-51
bimetal
temperature
switch



Temperature Switches

The Mercoid® DA-7035 Series bulb and capillary type temperature switches utilize the same Bourdon tube switching mechanism as the DA Series pressure switch. Temperature ranges to 530°F are available. The Series M51 is designed for use as a limit or alarm switch or as a fan control on furnaces, ovens, dryers, etc. with ranges to 650°F. The low-cost Series TS digital temperature switch is a state-of-the-art control used in heating and refrigeration systems.



Series DA-7035
temperature switch

products from Dwyer



Temperature/Process Controls and Sensors

The Love Controls Division manufactures a wide variety of temperature/process controllers for the packaging and molding industries. These controllers are available in 1/4, 1/8, 1/16 and 1/32 DIN sizes. Selectable control ON-OFF, P, PI or manual PID, or automatic SELF-TUNE® PID control is available. Series TST dual probe digital temperature switches are economically packaged with three SPST relays for refrigeration and defrosting applications.

Valves and Position Indicating Switches

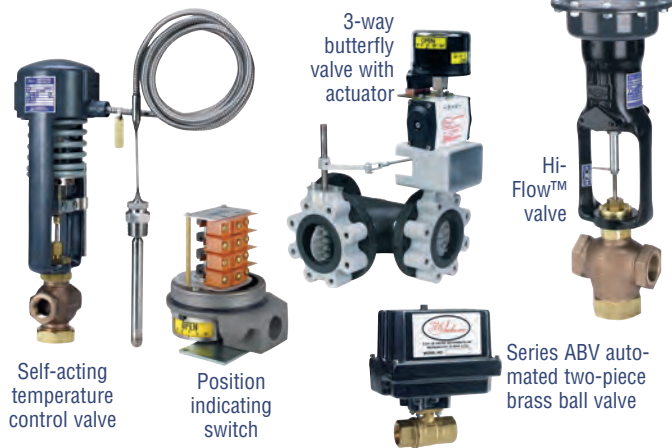

W.E. Anderson® pneumatic control valves are used in temperature control applications to protect sensitive equipment from overheating. Sizes available are 1/2" to 2" in bronze or 316 stainless steel material. Butterfly valves are also available from W.E. Anderson® in sizes 2" to 16" to meet your difficult application. 3-way butterfly valves with actuator are used to control the flow of water accurately in a water-side economizer system. Series ABV automated two-piece brass ball valves incorporate a full port brass ball valve for great flow rates with minimal pressure drop. Proximity® Controls Division manufactures position indicating switches that can mount on the Hi-Flow® valves and Plast-A-Vane® butterfly valves to give visual indication of and switch output of the valve position.



No. 1200-B
Combustion Test Kit

Combustion Testing Instruments

Individual Dwyer instruments measure furnace draft, the CO₂ content of flue gases, stack temperature, and smoke density. Usually supplied as a complete, portable kit for combustion efficiency testing, these instruments serve to adjust gas, oil, or coal fired furnaces and boilers for maximum combustion efficiency.

The Dwyer CO₂ indicators and monitors are also available separately, in various ranges for use in testing atmospheres on board ships and submarines, in greenhouses and in CO₂ blanketed flammable liquid tanks and compartments. The Dwyer 450 CO monitor is ideal for quickly monitoring carbon monoxide in ambient air and for detection of Carbon Monoxide in residential/commercial heating systems. Alarms may be set to give an audible indication of reaching a threshold.



Series 450
CO Monitor

New Products from Dwyer Instruments, Inc.



Minihelic® II
differential
pressure gage



Mini-Photohelic
differential pressure
switch/gage



Series 490 wet/wet
handheld digital
manometer



Series 616G
transmitter



Series DPG digital
pressure gage



Series DCT dust
collector timer controller



Series VR
View-Rite
Level
Indicator



Series 641 air
velocity transmitter



Series SFI 800
sight flow indicator/
transmitter



Series UV
Ultra-View™
polysulfone
flowmeter



Series PBLT (left) &
SBLT submersible
level transmitters



Series PLS
paddle level
switch



Series MPC
pump controller



Series P4
Ryton® Piston
Flow Switch



Series TS digital
temperature
switch



16S



Series
450 CO
Monitor

pressure

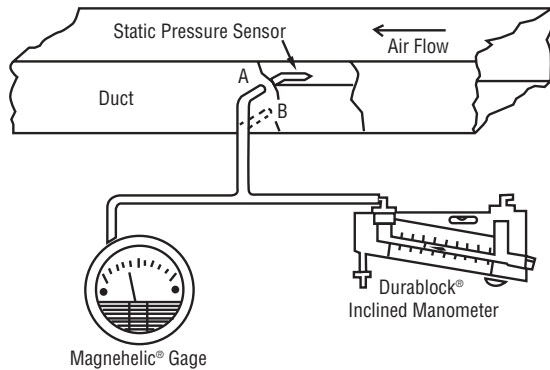

Measuring static pressure in an air duct or plenum.

Static pressure relative to atmosphere down to less than .01" wc can be measured directly using a Dwyer Magnehelic® differential pressure gage or any Dwyer manometer, inclined or vertical. If a manometer is used, an inclined type may be preferred to provide adequate resolution, particularly at very low pressures.

A static pressure sensor installed in the duct or plenum and connected to the high or low pressure port of the gage, as appropriate, does the job. While a static pressure sensor, or tip (A in the illustration) is recommended to reduce the effects of the turbulence, a flanged connection to a hole free of burrs in the wall of the duct (B) is also satisfactory for static pressure measurements when static pressure is relatively high and velocity relatively low.

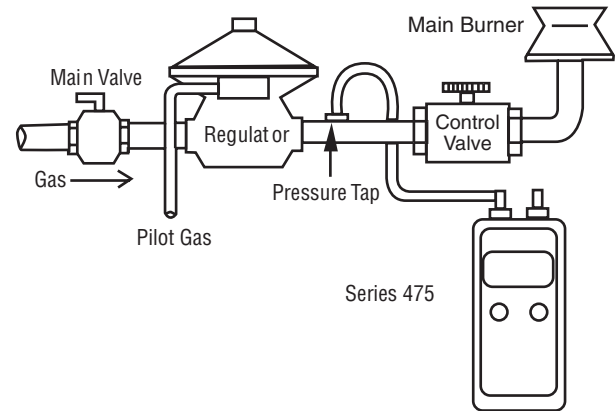

Digital Manometers used to check gas pressure to a heating burner.

Checking the gas pressure to a heating unit on the burner side of the regulator is a standard installation and service routine. The Dwyer Series 475 Handheld Digital Manometer is a low-cost, durable device that is easily transportable in a pocket or briefcase. Units are highly accurate with 0.5% full scale accuracy. Some servicemen prefer our portable Dwyer Magnehelic® differential pressure gage with dial type scale for field use.

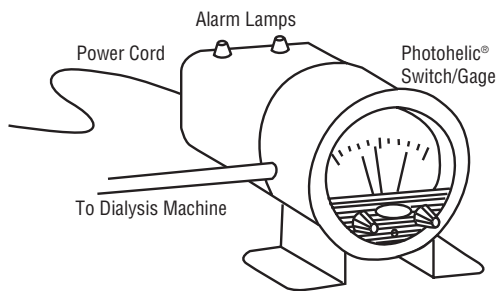

This portable monitor uses a Photohelic® switch/gage to show pressure and actuate hi-lo alarm signals during kidney dialysis.

This application for the Dwyer Photohelic® differential pressure switch/gage utilizes a standard unit as a self-contained arterial blood pressure monitor to be used with any kidney dialysis equipment. The gage is connected to drip chamber in the arterial blood line and monitors the pressure in the chamber. Instead of inches of water column, the gage is calibrated in millimeters of mercury. When blood pressure falls below or exceeds preset limits, a buzzer sounds and a "high" or "low" lamp lights which, for maximum patient safety, must be reset manually when pressure is again within the preset limits.

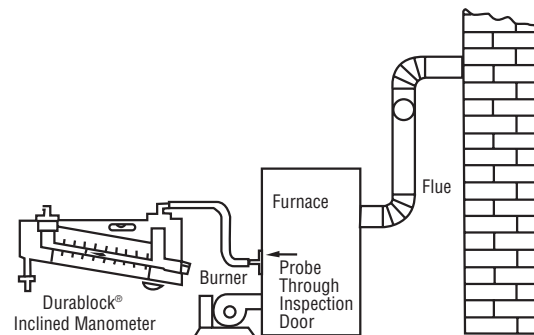

Using a draft gage to adjust for efficient combustion.

The amount of draft over the burner fire in oil, gas, or coal fired residential, commercial, or industrial furnaces and boilers is an important factor in combustion efficiency. A Dwyer Durablock® portable inclined manometer (when used in this application, it is commonly called a "draft gage") provides an easy, accurate measurement of the negative pressure over the fire or in the flue. A Magnehelic® differential pressure gage can also be used to make such a measurement. It offers advantages if continuous monitoring requires a permanent installation; it is easy to read, has no fluid to evaporate, and costs less. To optimize furnace combustion efficiency, use a Dwyer Model 1200 combustion test kit which tests for draft, CO₂, smoke density and stack temperature.

pressure

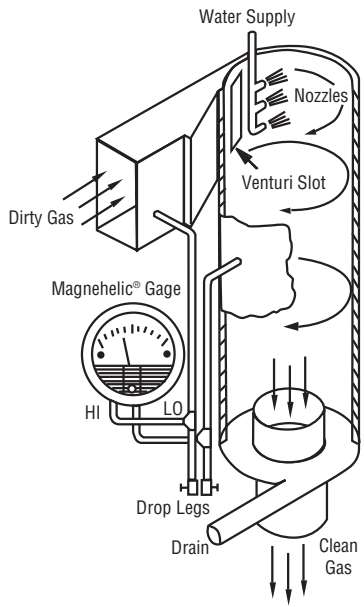

Differential pressure gage assists operator in adjusting venturi pressure drop in dust scrubber.

This scrubber design removes unwanted dust or particulate matter from air or gas using an adjustable throat venturi. To adjust the pressure drop across the venturi, a jack-screw-actuated sliding vane varies the slot width. A permanently mounted Dwyer Magnehelic® differential pressure gage indicates

the venturi pressure drop while the operator adjusts to the desired or design setting. Where water may possibly enter the gage sensing lines, as in this application, drop legs with drain valves are needed to permit draining the lines at their lowest point. Good engineering practice dictates that the Magnehelic® gage always be mounted above the sensing tap when possible to prevent moisture accumulation in the lines and gage. At minimum, mount the gage above the lowest point in the sensing lines.

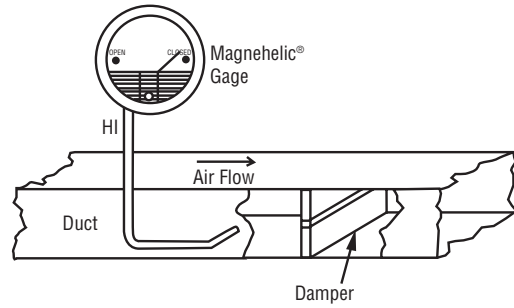

Gage indicates fire damper position in heating/AC duct.

The Dwyer Magnehelic® or Minihelic® differential pressure gages provide convenient visual indication of HVAC system fire damper position. Mounted in access doors (or another convenient location) with the high pressure port sensing upstream static duct pressure, the gage will read upscale should the damper close due to some failure. During system operational checks, each damper reaction can be easily monitored. This application eliminates difficult and time-consuming visual inspections - and encourages more frequent inspections for proper operation. If the rear of the gage will be exposed to dust-laden ambient air, a filter plug should be placed in the pressure port and vented to the atmosphere to prevent dust from accumulating in the gage over a long period of time.

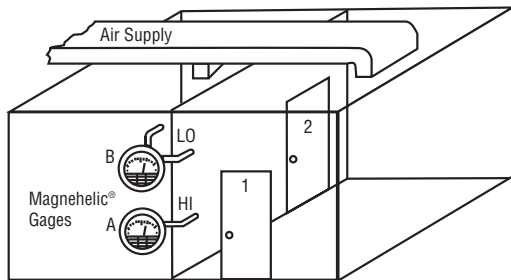

Dwyer gages indicate pressurization of special rooms.

A zero-center Dwyer Magnehelic® differential pressure gage with an 0.25" wc range either side of zero makes an effective monitor for proper operation of room pressurization systems. In the example, differential gage B has its high pressure port open to room 2 and its low pressure port to room 1; gage A has its high pressure port open to room 1 and its low pressure port open to the atmosphere. With the makeup air supply damper adjusted properly, room 2 will be a higher pressure than room 1 which is at higher than atmospheric pressure; both gages will read positive. Should the air supply to room 2 be obstructed, gage B will read negative. If the air supply fails entirely, both gages will read zero. For even better security, a Photohelic® switch/gage will provide automatic alarm or start-up of a backup system.

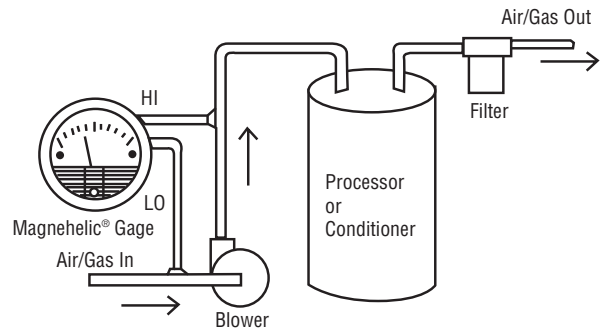

A choice of several Dwyer products will monitor or protect this processor.

When air or other gas must be pumped through a processor, measuring the differential pressure across the blower with a Magnehelic® differential pressure gage will monitor the flow rate as a function of blower static pressure to indicate proper operation. As an alternative, a Dwyer Photohelic® switch/gage can be used where deviations from normal flow due to filter loading, other restrictions in the system or blower failure require automatic shutdown of the system. Either a Minihelic® differential pressure gage or a Mark II manometer will serve if a lower cost gage is desired. If no visual gage is required, a Dwyer differential pressure switch will provide the automatic shutdown or alarm function.

pressure

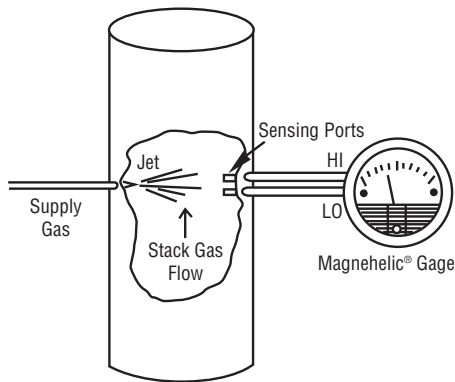

Sensitive gage measures low flow of stack gas.

In a hostile environment or in very low flow situations such as those encountered in stack gas flow measurements, flow can be measured more reliably by a proprietary device called a “fluidic flowmeter”. A jet of compatible supply gas envelopes both symmetrically placed sensing ports but is displaced in proportion to the flow of stack gas being measured. This results in a difference in pressure between the ports when flow is other than zero, causing the Dwyer Magnehelic® differential pressure gage to read upscale. Calibration can be direct or in inches of water in conjunction with a calibration curve or table. This device can be cleaned remotely by injecting solvent into the system. It also provides a measurement “gain” enabling lower velocity readings to be taken than is possible with other techniques.

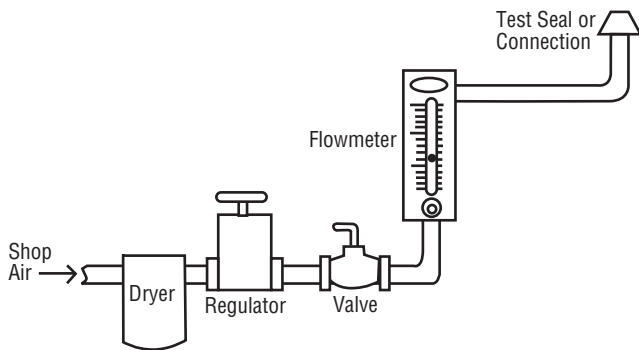

Another system of leak testing uses a Dwyer flowmeter.

A fast, repetitive check for leakage in various containers, valves, assemblies, etc. can be made with this test setup. During testing, the valve is opened after the dry air supply is set to the proper test pressure. As a low range Visi-Float® flowmeter is used to obtain sensitivity, the float will go to the top of the bore. However, as soon as a unit under test is placed in position, the float will fall to the zero mark if no leakage exists. The rate of any leakage will be a function of the flow indication. Dry air is usually necessary to prevent the float from sticking in the bore due to accumulated moisture.

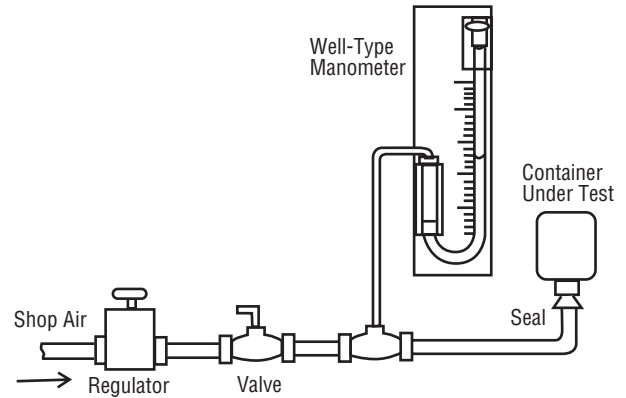

Dwyer well-type or inclined manometers used to check for leaks in containers or assemblies.

This setup provides a low cost means of checking containers or assemblies for no leakage or an acceptable rate of leakage. With the unit under test in place on the seal, the operator opens the valve to pressurize the system to the test level set by the regulator. After the well-type manometer stabilizes, the valve is turned off. Any leakage is reflected as a drop in the manometer reading, the leakage rate being proportional to the rate of drop in the reading. A Dwyer inclined manometer can provide an even more sensitive indication if required.

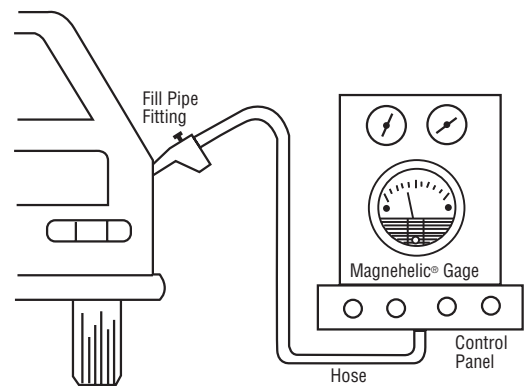

In-house engineers use a Dwyer gage on production line test for integrity of auto fuel systems.

An automobile manufacturer uses an in-house designed system for production line testing of fuel systems. The total system is a complex, integrated fluidic circuit that charges the automobile’s fuel system through the gas tank fill pipe. One section of the system senses leaks due to disconnected lines of faulty connections by monitoring the differential pressure between the auto fuel system and a reference tank with a Magnehelic® differential pressure gage after the charged system is sealed off.

pressure

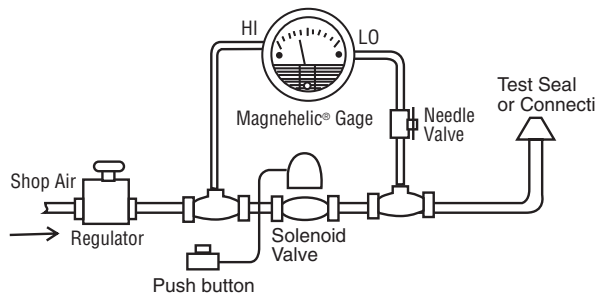

Leak testing done with low range differential pressure gages.

This setup provides a very sensitive and relatively fast method of leak detection. With one hand, the operator places the unit to be tested on the test seal and, with the other hand or one foot, operates the solenoid valve control button. With the unit under test in place, the normally open solenoid valve permits equal pressurization of both sides of the Dwyer Magnehelic® differential pressure gage, with a resulting zero reading. The needle valve is adjusted once to equalize the time it takes to pressurize both gage chambers and to minimize upscale gage readings during pressurization. When the solenoid valve is activated (closed) any leak quickly reduces the pressure on the low side of the gage and an upscale reading results. The availability of very low range Magnehelic® gages allows selection of a model which will quickly respond to a small leak with a significant reading, even at modest test pressures. As an alternative, use a Photohelic® differential pressure switch/gage to provide an alarm or, in automatic testing, “kick-out” of the leaky unit.

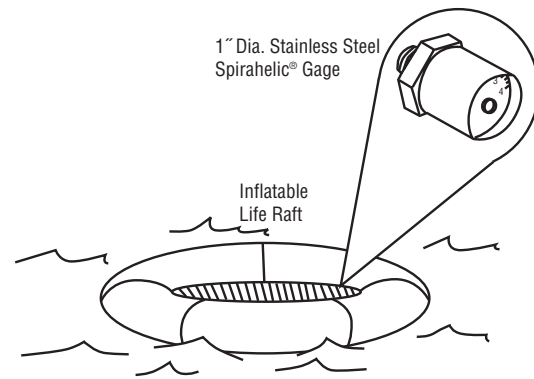

Inflatable life rafts include small 1 inch diameter gages.

Inflatable life rafts used on military and commercial aircraft require highly reliable components for obvious reasons. The inflation systems on some of these rafts include a very small version of the Spirahelic® gage to reveal the pressure in the compressed air bottle so it can be easily checked prior to flight. A Spirahelic® gage in a stainless steel case only one inch in diameter provides the required performance and reliability.

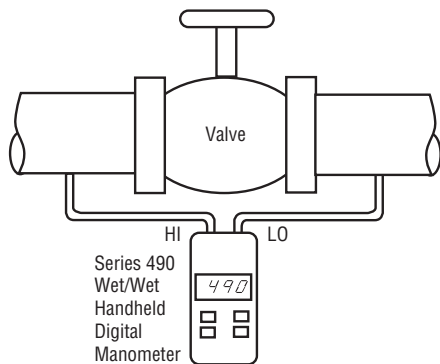

Measure pressure in hydronic applications.

The Dwyer Series 490 Wet/Wet Handheld Digital Manometer is a portable, industrial instrument designed for processes with liquids or gases. The 490 is often used to measure pressures in hydronic applications, but with all 316 stainless steel wetted parts it can also be used in systems where aggressive media is present.

In the above application, the 490 is used to measure the pressure differential on a control valve in a multi-story building water system. The user balances the pressure differential on the control valve to ensure every floor receives approximately the same pressure.

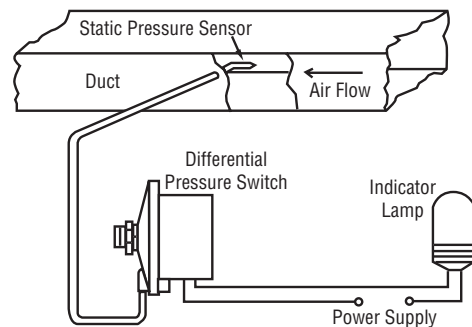

A differential pressure switch and warning lamp monitor static pressure.

The existence of a static pressure above or below a required level (compared to atmospheric) is easily determined by connecting an appropriately installed static pressure tip to the appropriate port of a differential pressure switch, such as a Dwyer Series 1600, 1800 or 1900 differential pressure switches. When the pressure reaches the preset switch point, the contacts are closed to activate a warning lamp or other alarm device. It is good practice to mount the differential pressure switch with the ports down to prevent moisture from entering the diaphragm chamber. The diaphragm should be vertical and in the same plane as any vibration or anticipated shock movement.

pressure

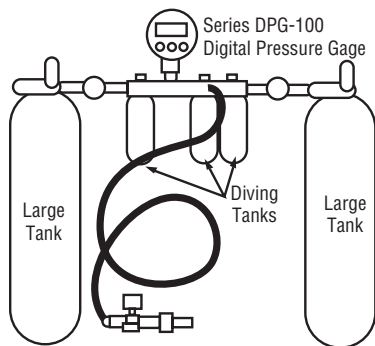

Filling Scuba Diver's Air Tanks.

The Dwyer Series DPG with oxygen cleaning and 5000 psi range is used in gas blending applications for filling scuba diver's air tanks. The DPG is the master mixing gage in this manifold apparatus. Two or three gases may be blended with the manifold to produce the appropriate blend of breathable gas depending on the diver and the depths they will reach. With the flow adjustment knobs and the 0.25% full scale accuracy DPG, precise tank charging rates are maintained.

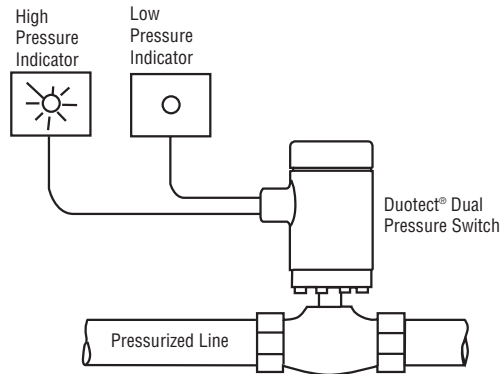

One diaphragm actuates two independent explosion-proof switches in Duotect® pressure switch to monitor pressure.

High pressure lines or systems for air, gases, or liquids can be monitored for proper pressure between desired limits with a Duotect® dual pressure switch. Independent low and high alarm or control points can be set from 5 to 1500 psig. With two individual switches operating from a common diaphragm, one Duotect® switch does the job. The high and low pressure indicators or alarms are activated only when the limits are exceeded; both are deactivated when the pressure is within the limits. The Duotect® switch is explosion-proof and can be used with hazardous media or in explosive atmospheres.

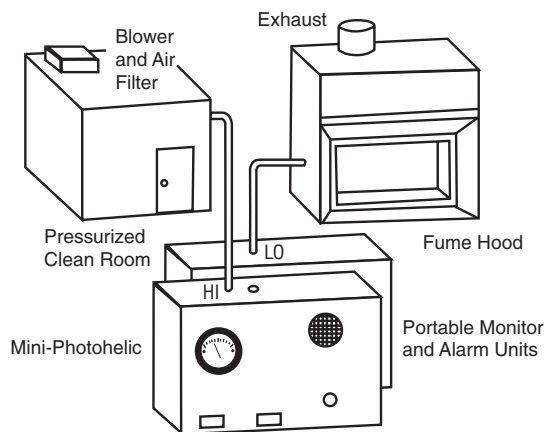

Compact switch/gage monitors pressure, actuates alarm.

This portable pressure monitor alarm utilizes a Dwyer Mini-Photohelic differential pressure switch/gage to monitor either positive pressure, as in a clean room, or negative pressure, as in a fume or paint spray hood. It sounds an alarm, both audible and visual, when pressure exceeds either a preset high or low limit. The unit can be used temporarily to verify proper operation after initial installation. Or it can be mounted permanently for continuous monitoring. In applications where a single fixed alarm pressure level is sufficient, a differential pressure switch can be used instead.

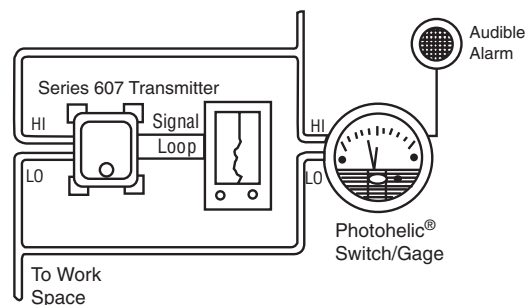

Transmitter and Photohelic® switch gage monitor negative pressure during asbestos removal operations.

During asbestos removal operations, it is essential to monitor and record the negative pressure compared to atmosphere which must be maintained in the work space to prevent escape of airborne asbestos particles. A Dwyer Series 607 transmitter provides a 4-20 mA control loop signal proportional to pressure to a strip chart recorder with a 4-20 mA input configuration. Thus, a permanent record of work space pressure is obtained. To provide an audible alarm should the pressure go positive for any reason, a Dwyer Model 3000-00N SR Photohelic® switch gage is connected in parallel with the transmitter sensing line and connected electrically to an audible device. The Model 3000-00N-SR features an offset zero pressure point to actually allow below zero indication of pressure plus a single setpoint adjustable from the front of the gage for setting the alarm level at or within a few hundredths of an inch of water column of zero room pressure.

pressure

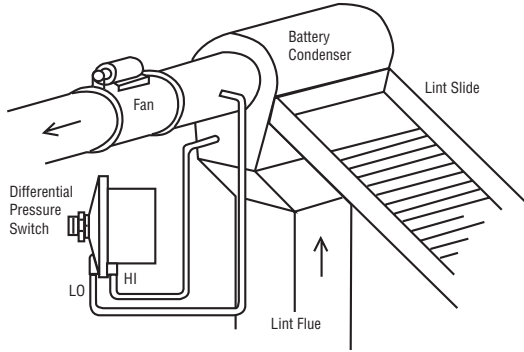

Switch senses air pressure changes in textile equipment.

In the textile industry, a Dwyer differential pressure switch is used to determine when cotton is passing through a battery condenser. It is used with a control unit to stop a water pump and turn down a burner when no cotton is being ginned. The switch works by sensing the difference in air pressure between the two sides of the condenser screen. When no cotton is on the screen, the pressure difference will be almost zero. When a batt of cotton is being condensed, the air pressure inside the screen will be lower than the air pressure in the lint flue. The switch senses this difference and closes an electrical contact. Filters are recommended at the tap end on the sensing lines in this type of application, as particulates can clog the sensing lines or accumulate in the switch.

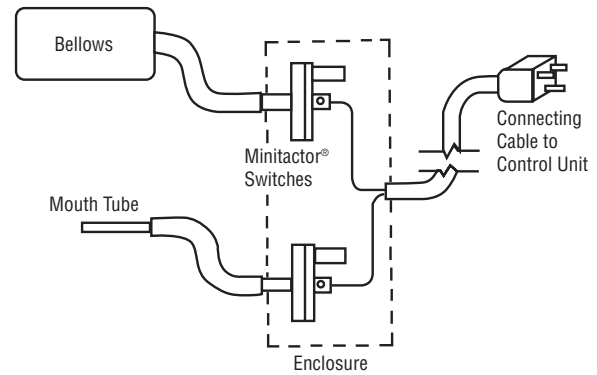

Physically challenged individuals control equipment with Dwyer switches.

Low cost Dwyer Minitactor® differential pressure switches will sense pressures produced by physically challenged individuals to control electrical devices which render them assistance. The soft cushion-bellows can be squeezed by almost any body contact and the gooseneck mounted mouthpiece blown into by mouth to activate the Minitactor® switches. The mouthpiece can also be teed into a third Minitactor® switch on the low pressure side so both blowing and sucking can produce separate control functions. These sensors are both very sensitive and safe as the electrical circuits are isolated from the individual by the rubber tubing.

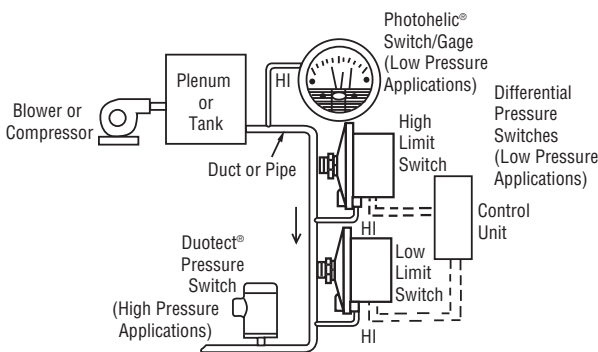

Controlling pressures in air or gas systems.

Air pressure can be controlled in a system by using a Dwyer Photohelic® differential pressure switch/gage, one or two Dwyer differential pressure switches, or a W.E. Anderson Duotect® pressure switch, depending on the range of control and/or levels of pressure involved. All of these switches monitor the pressure in the system and will cause the pressure source - a blower, compressor or pump - maintain the system pressure within the preset high and low levels. For systems using low pressures (.01" wc to 10 psig), the Photohelic® switch/gage or Dwyer pressure switches are the best choice. For higher system pressures (5 to 1500 psig), we recommend the Duotect® pressure switch. When you install differential pressure switches on air systems, it is best to mount the switch with ports down to prevent moisture from entering the diaphragm chamber - and with diaphragm vertical and in the same plane as any vibration or anticipated shock movement.

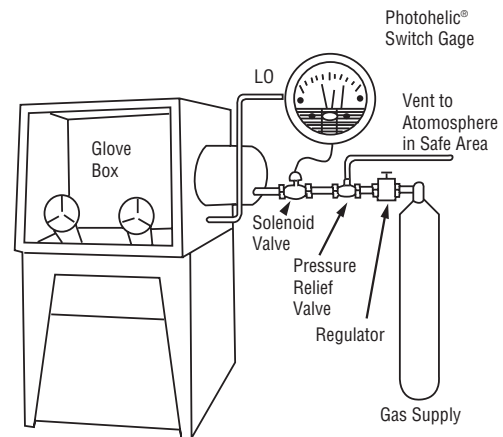

Zero-center switch/gage controls the inert atmosphere in glove box.

A controlled inert atmosphere "glove-box" is used in the fields of physical chemistry and metallurgy for handling and welding special or hazardous materials. A Dwyer Photohelic® differential pressure switch/gage serves as an automatic and readily adjustable pressure control for the helium, argon or nitrogen gas used in the system. The box is first evacuated, then pressurized with the required gas. Therefore, a zero-center Photohelic® switch/gage is used, permitting both pressure and vacuum to be read and controlled by a single gage. Use of the low pressure gage connection (rear chamber of gage) and a Buna-N diaphragm is suggested to minimize leaks from or to the atmosphere.

pressure

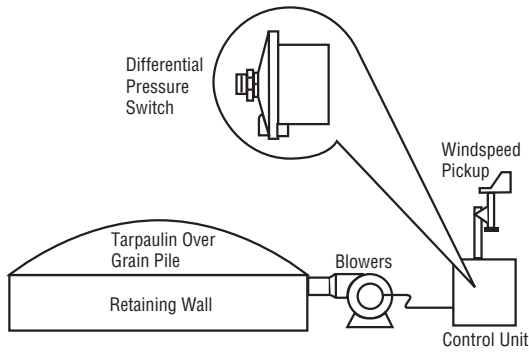

Dwyer Wind Speed Indicator and differential pressure switch control fans to hold down grain pile cover.

Grain piled out of doors must be protected from the weather by a tarpaulin cover. To hold the tarpaulin in place during periods of high wind, this system utilizes a row of exhaust blowers mounted through one retaining wall to create a negative pressure under the cover. The blower control unit uses a Dwyer Wind Speed Indicator pick-up to sense velocity pressure and activate a Dwyer differential pressure switch at a pre-determined wind velocity. Therefore, the fans are turned on only when necessary to conserve electrical energy. A Photohelic® switch/gage could also be used to provide readout of velocity pressure and visual indication of the blower activation setpoint as well as easy field adjustment of the setpoint to meet varying conditions.

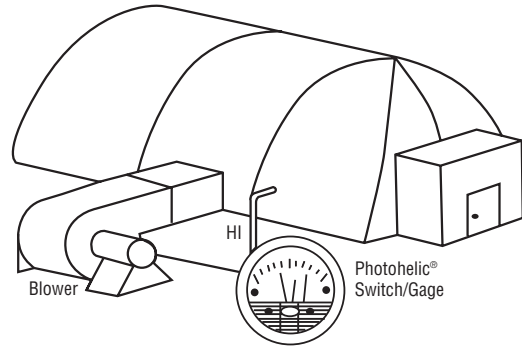

Switch/gage regulates pressure in air-inflated buildings.

To control pressure in air-inflated buildings, the high pressure port of a Dwyer Photohelic® differential pressure switch/gage is connected to a tap in the building wall. The unit senses over-pressure that may over-inflate the building - or loss of pressure that may result in collapse - and controls the blower to maintain correct pressure. The gage is easily reset to conserve power or provide extra pressure to resist strong winds. Although two regular pressure switches plus a latching relay may also control the blower automatically at lower cost, the Photohelic® switch/gage is preferred, as it permits both visual reading of inflation pressure and easy adjustment of set points to meet varying conditions.

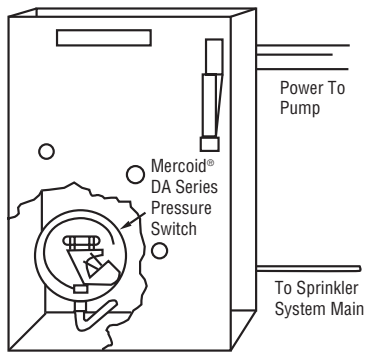

The Mercoid® DA Series is the industry standard pressure switch for fire pump controls.

Fire pump controls operate pumps, supplying water to building fire sprinkler systems. These controls turn on the main pumps when system pressure falls due to sprinkler heads being activated. Fire pump controls also turn on smaller make-up pumps to maintain system pressure, which may fluctuate due to small leaks. These controls almost always employ the Mercoid® DA Series pressure switch due to its rugged design and high reliability over long periods of infrequent operation. The DA Series switch provides independent high and low setpoints over the entire pressure range of the switch to meet varying requirements from system to system. The low setpoint maintains minimum pressure required for proper system operation while the high setpoint prevents damage due to over-pressurization of the system.

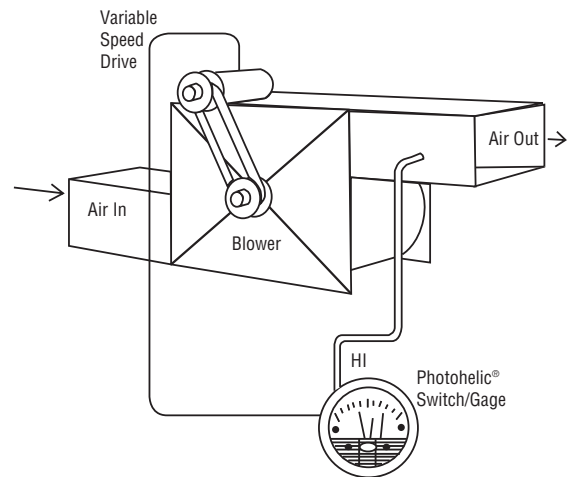

Switch/gage controls blower speed to save energy.

Variable-speed blower drives are gaining popularity as a very energy-efficient method of controlling air flow. In a typical system, a Dwyer Photohelic® differential pressure switch/gage monitors the static or velocity pressure in the duct downstream from the blower and, within the preset high and low pressure limits of the null band, the switch/gage controls blower drive speed to maintain the desired pressure. To meet changing conditions, the manual knobs on the Photohelic® switch/gage permit easy resetting of control limits.

pressure

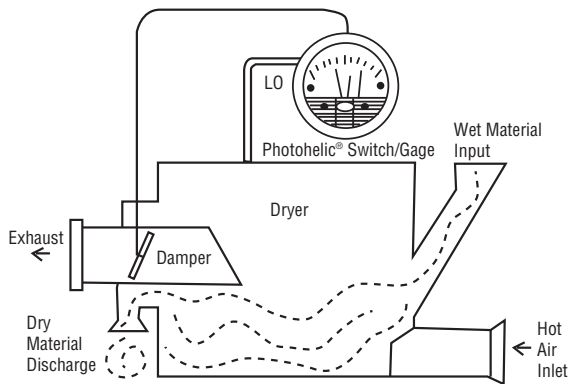

Fuel savings result from switch/gage draft control.

Automatic vent dampers conserve energy in residential furnaces by closing completely when burner is off to prevent wasteful heat loss up the flue. However, in some industrial heating applications like this asphalt plant dryer, burners run continuously. To save energy, another form of automatic damper control maintains a constant exhaust draft at the point required for most efficient operation. In this application, a Dwyer Photohelic® differential pressure switch/gage monitors the negative static pressure in the dryer and maintains the desired draft by signaling the damper actuator to change the damper position when the upper or lower limit is reached. Cost savings can be substantial in high fuel usage systems of this type.

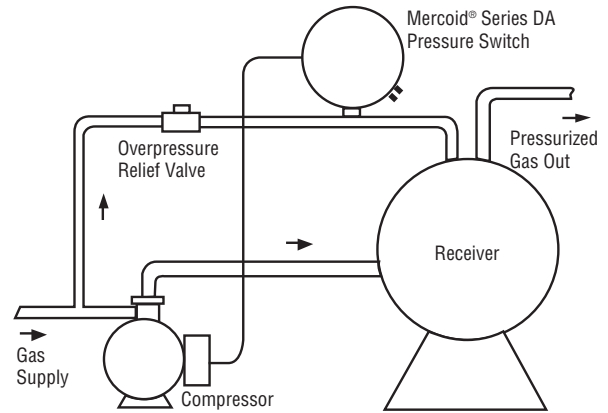

Mercoird® Series DA pressure switch maintains desired gas pressure in tank.

Demand for compressed gas varies in this gas line. So a Mercoird® Series DA adjustable deadband pressure switch is included to turn the compressor on at low pressure and off when the maximum pressure is reached.

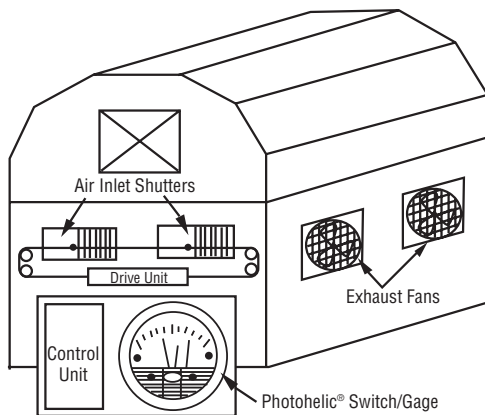

Power operated shutters on barn controlled by Photohelic® pressure switch/gage.

Controlled environment farm buildings are home to a variety of livestock and temperature and ventilation are as important to their well-being and growth as proper food and waste removal. The Dwyer Photohelic® differential pressure switch/gage, mounted in a control panel, will sense inside static pressure compared to outside atmospheric conditions and adjust the power operated shutters on the fresh air inlets. This maintains the required negative pressure in the building to ensure proper ventilation. Temperature sensors also provide input to control fan speed as necessary depending on outdoor conditions.

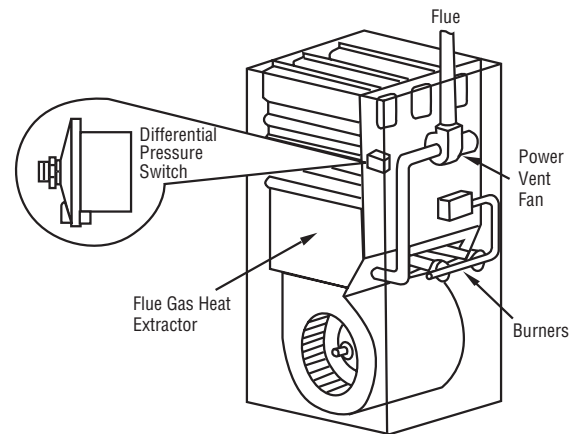

Furnace protected from inadequate draft by fail-safe differential pressure switch.

The high cost of home heating fuels has produced demand for more efficient furnace designs. One such furnace includes an additional stainless steel cell through which flue gases are routed to extract heat otherwise lost up the flue. The relatively cool flue gas then requires power venting by means of an induced draft fan. A Dwyer differential pressure switch is built in to prove adequate draft by sensing the negative draft pressure compared to atmosphere. If the fan or pressure switch should fail, the burners are shut off automatically.

pressure

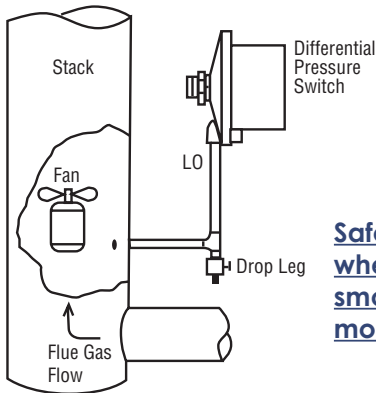

Safety is increased when draft in the smokestack is monitored.

In this boiler installation, a differential pressure switch signals when the natural draft in the smokestack is insufficient, and alerts the operator for corrective action. The low pressure port of the switch is connected to a tap at the base of the smokestack and the high pressure port is left vented to atmosphere. The same set-up can also be used to monitor operation of forced drafts and shut off firing if a fan fails. In addition to this switching function, a Dwyer Photohelic® differential pressure switch/gage will also provide a visual indication when required. Be sure to consider compatibility of the pressure switch components with the flue gases in applications of this type. In flue gas application, it is wise to provide condensate drop legs and drain valves in the sensing line.

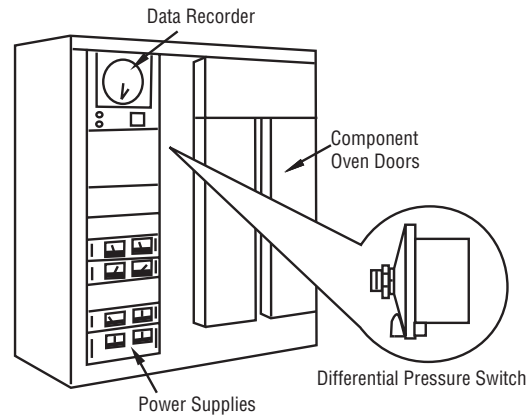

Differential pressure switch protects products on test.

The vast number of semiconductor devices manufactured for high reliability applications in computer systems, particularly memory devices, requires weeding out those that will fail early. They are subjected to a burn-in process, i.e., power is applied to the device to “exercise” it in a high ambient temperature. Fans move air over a bank of heating elements and then over the devices being processed. Failure of these fans can damage the burn-in equipment as well as delay completion of the testing of thousands of devices. A Dwyer 1900 Series differential pressure switch is installed to monitor air flow and signal an alarm immediately upon cessation of proper flow.

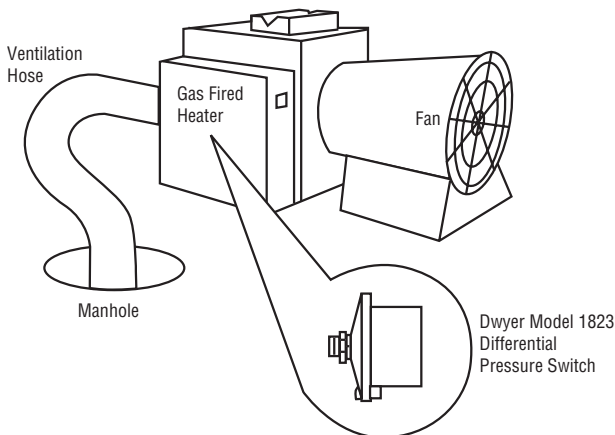

Utility manhole ventilation air heater protected by Dwyer differential pressure switch.

Manholes providing access to various underground utility systems must be ventilated with fresh air for worker safety. In cold weather, heating the ventilation air also provides worker comfort. This small gas-fired heater can be inserted between the ventilation fan and hose. A Dwyer differential pressure switch is used to sense air flow through the heater as a function of static pressure. It will shut down the gas burner if the static pressure falls below a level indicating insufficient air flow due to fan failure or an obstructed air intake.

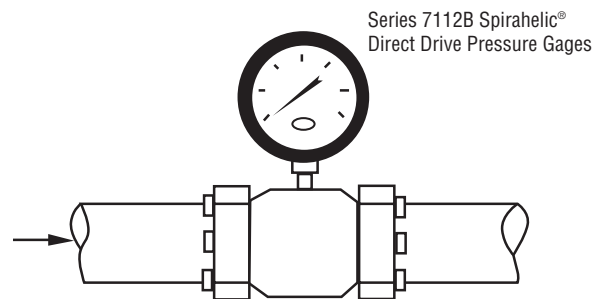

Process gage monitors line pressure.

The 7112B Spirahelic® gage with direct drive triple wound Bourdon tube and ASME Grade 2A accuracy is often used on process lines to monitor pressures. Ranges from 30 PSIG up to 10,000 PSIG are available along with several compound ranges for systems that experience pressures below zero. The triple wound Bourdon tube technology allows the Spirahelic® Gage to withstand vibration, pulsation and shocks without damage or the need for recalibration.

pressure

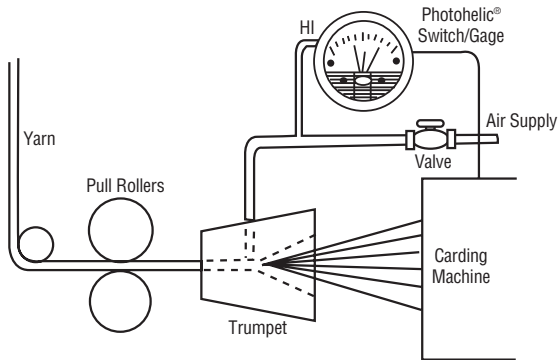

Yarn size from carding machine controlled by switch/gage.

The size of a “rope” of permeable materials, such as the yarn produced by carding machines in the textile industry, can be controlled by air pressure sensed by a Dwyer Photohelic® differential pressure switch/gage. On these machines, the amount of fiber supplied for the yarn causes its diameter and density to change proportionally. The backpressure created by a larger and denser yarn in the trumpet increases the pressure sensed by the switch/gage until the preset upper limit is reached and the switch causes the carding process to slow down. When it slows, the yarn becomes smaller and less dense until the pressure falls to the switch/gage’s preset low limit and the carding unit is signaled to speed up. The amount of air supplied controls the desired size of the yarn. Opening the valve reduces yarn size by providing the preset backpressure from a less dense yarn and vice-versa.

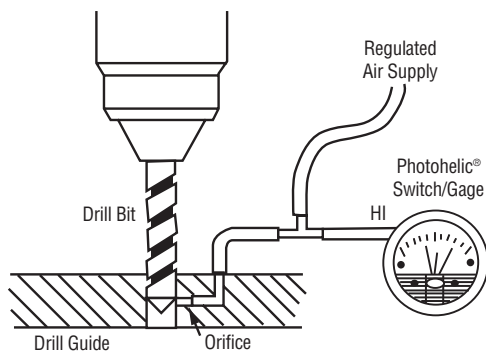

If drill breaks, switch/gage will stop machine.

A Dwyer Photohelic® differential pressure switch/gage on this fixture detects breakage of drills or reamers in automatic machines and shuts down the process immediately upon breakage. It prevents additional damage where tapping or other operations follow in the process. In the fully retracted position, an orifice in the drill guide is located just above the cutting lip of the drill. Regulated air pressure is supplied to the orifice and teed to a Photohelic® switch/gage. As long as the drill is intact, pressure remains high. If the drill breaks, the missing drill tip allows pressure to drop below the minimum set on the gage and the relay closure signals the process to stop. The switch/gage will also actuate an alarm if desired. Although a simple differential pressure switch could be used, the Photohelic® switch/gage is superior for this application, as it permits instant adjustment for various machine setups.

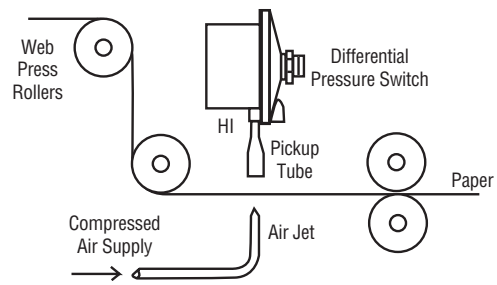

When paper web breaks on printing press, air jet reaches pressure switch, which signals control to stop press.

Large, high-volume web printing presses move paper through the press from continuous rolls at very high speed. When the paper strip, or web, breaks accidentally, the press must be stopped quickly or a large amount of paper is lost and cleanup takes valuable time. To prevent such losses, the integrity of the web is often monitored by a Dwyer differential pressure switch connected to a pickup tube opposite a jet of air on the other side of the web. When the web breaks, the air flow from the jet causes pressure to rise in the pickup tube, closing the switch which signals the main control unit to shut down the press. The pressman regulates the jet pressure to minimize air consumption based on the desired response time.

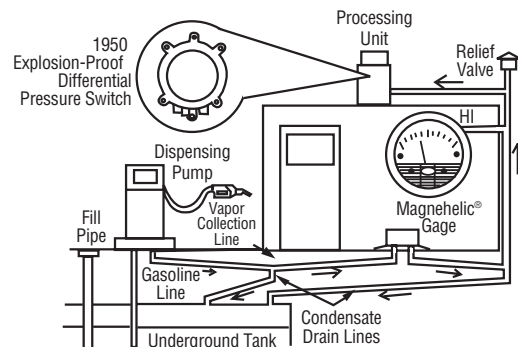

Gasoline vapor recovery system.

Some area pollution control agencies require that 90% or more of gasoline vapor vented at service stations when fuel is dispensed must be prevented from venting to atmosphere. Using a dual hose dispenser, this vapor recovery system is a vacuum assist, vapor burnoff type. The blower creates a low vacuum at the nozzle, routing vapor from the automobile tank to underground storage tanks. As uncondensed vapor pressure reaches 2” to 3” w.c. pressure, a Dwyer 1950 Series explosion-proof differential pressure switch activates a rooftop burnoff unit, which ignites excess vapor. The Magnehelic® differential pressure gage mounted on the station wall monitors tank pressure to verify system operation. The gage is calibrated in inches of gasoline, from +6 to -2. This allows the operator to determine the necessary level correction due to tank pressure prior to dip-sticking the tanks through the fill pipe.

pressure

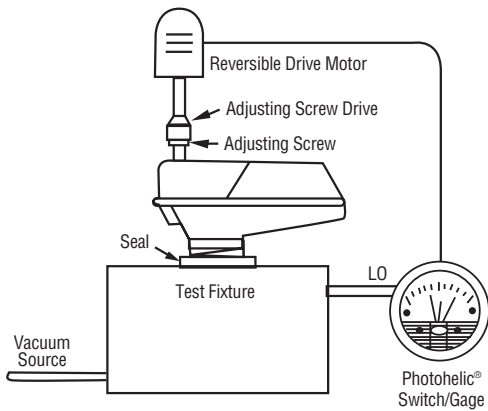

Dwyer switch/gage controls tank fill valve setting.

This unique toilet tank fill valve replaces older ballcocks and floats. It is controlled by a diaphragm exposed to the head of water in the tank. An adjusting screw allows the installer to set the correct level of water in the tank for proper flushing with minimum water. During production, this fixture automatically sets the adjusting screw to a common 18" to 20" water column. The fixture draws a vacuum on the lower side of the diaphragm to simulate water pressure on the top side and a Dwyer Photohelic® differential pressure switch/gage samples this vacuum via the low pressure port. With presets at 18" low and 20" high limits, a reversible motor on the fixture engages the adjusting screw and drives it to the point where the valve closes in the desired 18"-20" range.

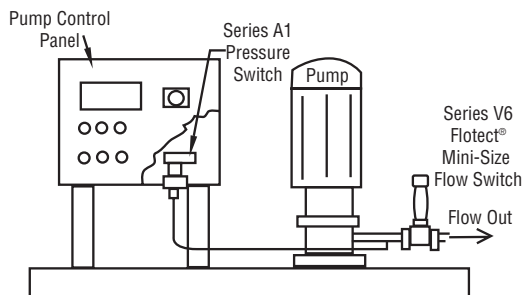

Mercoïd® A1 pressure switch and W.E. Anderson® V6 flow switch are incorporated into irrigation pumping station.

The pumping station is used to provide water for irrigation purposes and contains one to four pumps with a pump control system. To protect the pump a loss of prime protection is included in the system. A pressure switch is installed in the system and signals a low pressure alarm. Then if the V6 flow switch signals no flow a timer starts and if there is no flow through the system for a given time period the pump is shut down. The flow switch by itself also trips a low flow condition for pump shut down even if pressure does not fall. The A1B-OP is perfect for this application as it was designed to mount in the bottom of the pump station control panel. It mounts flush through the bottom of the panel and comes complete with a sealing gasket and nut to make sure the switch seals off tightly against the panel keeping it weatherproof. Mounting in this fashion saves the cost of using weatherproof pressure switches. The V6 flow switch is also well suited for this application with its robust and weatherproof design.

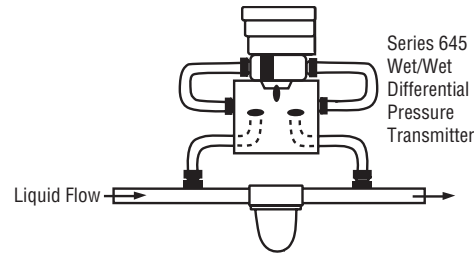

Three-valve manifold simplifies installation of wet/wet differential pressure transmitter.

When using differential pressure transmitters in fluid applications, it is essential to periodically make sure that there is no air in the system, as this can cause erroneous readings. Unfortunately, the necessary three-valve bleed system is often expensive and large, making installation difficult and bulky. For this reason, Dwyer offers the 3V option on all 645 Wet/Wet Differential Pressure Transmitters. This compact, lightweight, and economical bleed manifold is shipped factory-installed on the 645, eliminating the hassle of constructing a custom apparatus. The 645, when combined with the three-valve option, makes for an ideal setup to monitor hydraulic filter clogging or other fluid pressure sensing applications.

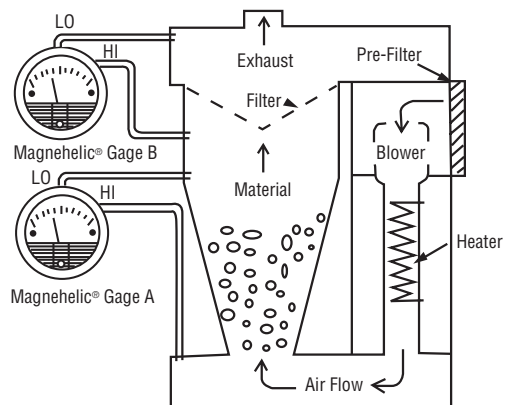

Two differential pressure gages reveal filter condition in lab dryer.

This laboratory dryer is used to dry small batches of chemical compounds, drugs, fertilizers, foods, etc., for research and development purposes or to prove production techniques. Room air is drawn in through the pre-filter, passes through the blower and over the heating coils. The blower forces heated air up through the material to be dried. The Dwyer Magnehelic® differential pressure gage A monitors the pressure drop across the material to detect any blockage developing. The exhausted air then passes through a final filter. To monitor the condition of that filter, Magnehelic® gage B measures the associated pressure drop. Minihelic® gages would also be suited to this application.

pressure

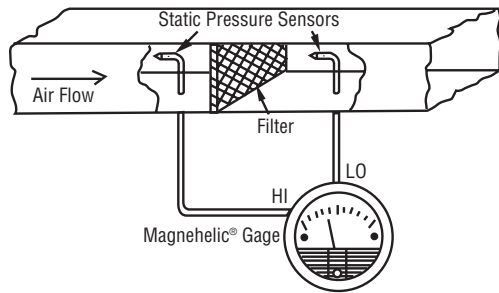

Several types of Dwyer differential pressure gages are well suited to monitor the condition of filters.

A Magnehelic® air filter gage instantly reveals when filters need servicing. Select a Magnehelic® gage model with range appropriate to the filter manufacturer's recommendation for maximum permissible pressure drop across the filter. Install the gage with a red adjustable signal flag (optional) set at the maximum allowable pressure drop point for the air volume being handled. This speeds the reading of gage, even by relatively inexperienced personnel. Portable kits complete with static tips, tubing and hardware are available. Instead of the Magnehelic® gage, our Photohelic® differential pressure switch/gage will automatically actuate an audible or visual alarm when filter needs servicing. Where a very high degree of accuracy is required, an inclined manometer, such as the Dwyer 100 or 200 Series Durablock® models, can be used to measure pressure drop. If low cost is most important, our Mark II, Model 25 manometer will indicate pressure drop.

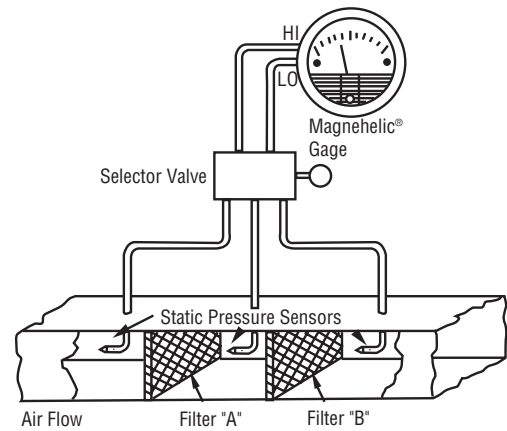

Two filters served by one gage and Dwyer selector valve.

Where dual filters are installed, a single Magnehelic® differential pressure gage can be used to monitor the condition of each filter, using the arrangement illustrated above. With the knob on the Dwyer A-365 selector valve pushed in, the static pressure sensors across filter A are connected to the appropriate ports on the gage. Pull the selector valve knob out and you connect the static pressure sensors across filter B to the gage. Be sure to select a gage range appropriate to the specified pressure drop for both filters. If desired, substitute a Photohelic® differential pressure switch/gage or Durablock® inclined manometer for the Magnehelic® gage.

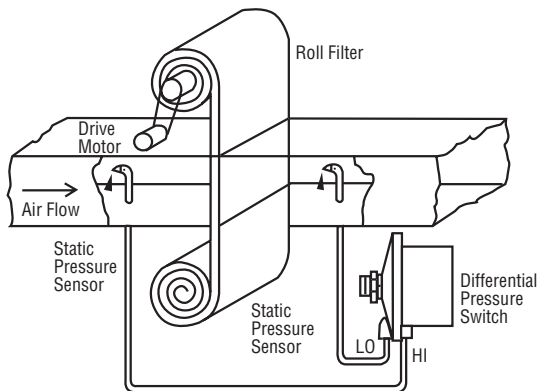

Differential pressure switch actuates roll filter motor when dust reduces air flow.

When dust build-up on this roll filter increases the filter's resistance to air flow, the increased pressure drop across the filter is sensed by the differential pressure switch, which starts a motor to roll a new section of filter into place. A Dwyer Photohelic® differential pressure switch/gage can also provide this type of automatic control. It has the added advantage of continuous visual indication of the pressure drop for routine checking by maintenance personnel, as well as front-mounted knobs for instant adjustment of high and low pressure limits.

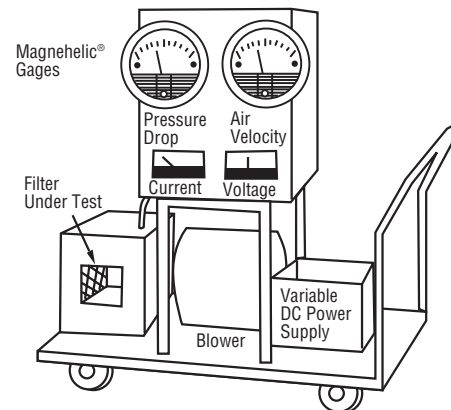

Test unit compares efficiency of various filter design.

The basic function of this filter testing system is to aid in conserving energy. It provides accurate comparative data for similar filters to help the operator select or specify the filters that provide maximum efficiency with minimum pressure drop. A variable speed blower draws air through the filter under test. Blower voltage and current are indicated on panel meters. One Magnehelic® gage monitors static pressure on the blower side of the filter, and exhaust air velocity is indicated by a second Magnehelic® gage connected to a Pitot tube in the exhaust duct. For a given air velocity, filter pressure drop and electrical energy required can easily be determined for various filter designs.

pressure

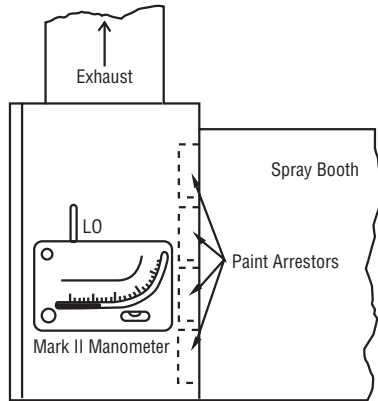

Low-cost Dwyer manometer indicates when to change filters in industrial paint spray booth.

Industrial spray-painting booths equipped with paint arrestors need monitoring to indicate when arrestor maintenance is required. The low-cost Mark II Model 25 manometer is widely used for this. Usually, the manometer is mounted to the outside wall of the booth for easy observation, and the low pressure tap is made directly through the wall of the booth to the exhaust side of the system. The manometer's high pressure port is left unconnected as the area around the spray booth is at ambient room pressure. A Dwyer Vaneometer can also be used to check face velocity at the open side of the spray booth.

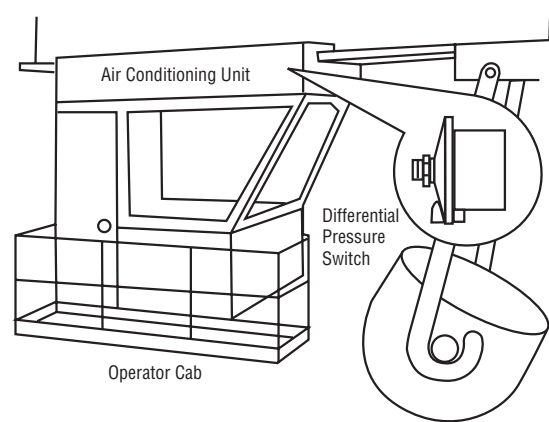

When A/C filters in operator's cab need cleaning, a Dwyer pressure switch actuates a visible or audible warning.

Concern for efficiency and safety, as well as compliance with federal regulations, has produced a need for operator enclosures on equipment used in areas with high ambient temperatures and heavy air pollution. Such enclosures are supplied with filtered and conditioned air to insure operator comfort and safety. Dwyer differential pressure switches are specified to monitor the pressure drop across the filters in the compact, heavy-duty air conditioners installed in the cabs. The switches actuate a visual or audible warning when filter cleaning or replacement is required.

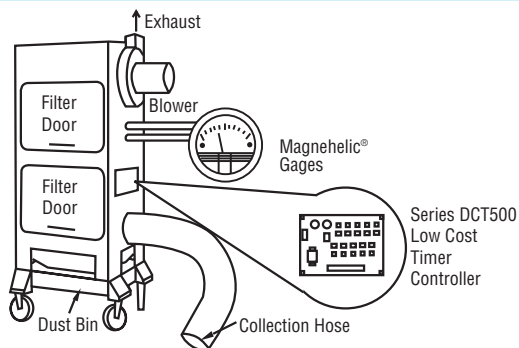

Dust Collector Timer Controller shows filter condition in dust collector.

This portable dust collector can be rolled from job to job in an industrial building. An operator places the large diameter collection hose where it is needed and dust is collected by filters located inside the access doors on the units side. The top mounted blower draws air through the filters. To monitor the pressure drop across the filters, the manufacturer supplies a Magnehelic® differential pressure gage. When the pressure drop due to dust build up on the filter indicates that cleaning is necessary, the DCT500DC Dust Collector Timer Controller is manually activated to initiate a cleaning cycle which involves solenoid valves releasing pulses of air. This process removes the dust from the filters where it drops into a storage bin. A Dwyer Minihelic® differential pressure gage can be used instead of the Magnehelic® gage, and, if automatic cleaning is required, a Photohelic® differential pressure switch/gage can provide the electrical contact to actuate the cleaning cycle when the pressure drop reaches the preset limit.

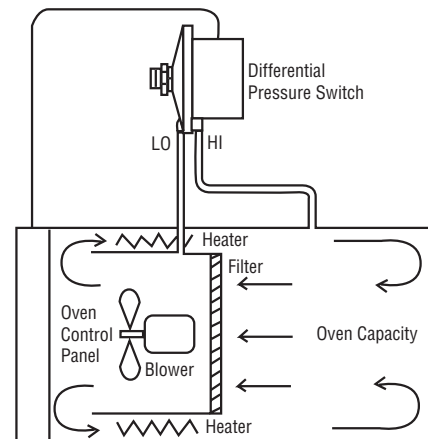

Commercial warming ovens include differential pressure switch to alert operator if fan fails or filter clogs.

Many large commercial warming and baking ovens require forced air circulation. They are protected against overheating due to blower failure or filter clogging by a Dwyer differential pressure switch, which monitors the pressure drop between the oven cavity and the inside of the fan duct. Should the pressure drop exceed the preset standard, the switch will turn off the oven heaters and light a panel alarm indicator.

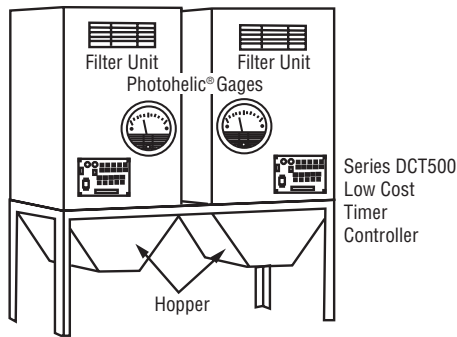

Automatic filter cleaning control system.

An automatic filter cleaning control system is created with the combination of the Dwyer Photohelic® switch/gage and a DCT500 Dust Collector Timer Controller. The Photohelic® gage monitors the filters for dust build-up. When the dust build-up and pressure drop across the filters exceeds a preset limit, the Photohelic® gage activates the DCT500's cleaning cycle. The DCT500 controls the cleaning process until the dust levels and corresponding pressure drop on the filters falls back below the preset limit. Static pressure taps and line filters are recommended to prevent migration of particulate into the Photohelic® gage.

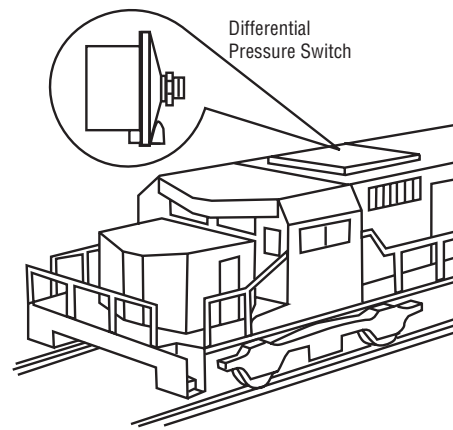

Alarm light triggered by Dwyer pressure switch alerts diesel engine maintenance crews to service air cleaners.

The large air cleaners on diesel locomotives must be serviced promptly when the particulate build-up on the filter element exceeds a safe level. To monitor filter pressure drop in this application, the engineers specified a Dwyer 1910 differential pressure switch. It performs reliably despite severe shocks and vibration as well as elevated ambient temperatures. When the pressure drop exceeds the preset level of the switch, a red alarm light goes on in the engine cab. The alarm is latched in the "on" position, alerting maintenance crews at the destination to the need for air cleaner service.

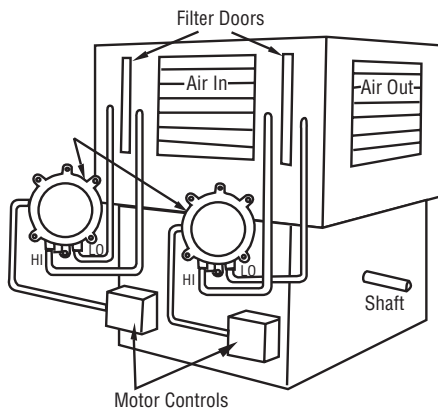

Cooling air for big motor passes through filter monitored by explosion-proof differential pressure switch.

This large electric induction motor has rotor mounted fans that draw cooling air into each end of the motor, across the rotor, and out through the stator into an exhaust duct. To prevent accumulation of dirt and dust in the motor, incoming air is filtered. The condition of each filter is monitored by a Dwyer 1950 explosion-proof differential pressure switch which senses the differential pressure drop across the filter. An explosion-proof switch is required since this inherently safe motor design is used to drive gas compressors. If the filter pressure drop reaches a preset high limit, the switch shuts down the motor and signals an appropriate alarm.

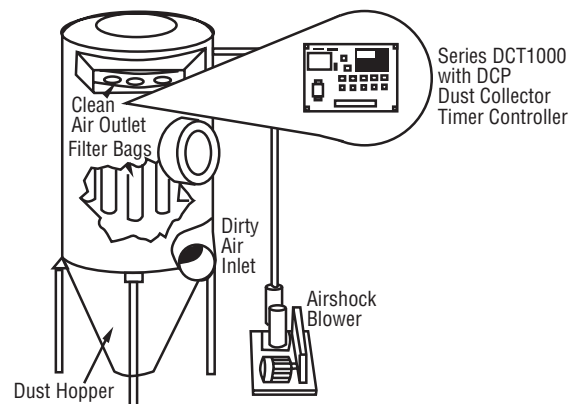

Bag house cleaning system uses Dust Collector Timer Controller to initiate optimum cleaning cycle.

A Dwyer DCT1000 Dust Collector Timer Controller with attachable DCP pressure sensing module monitors and controls the dust levels and corresponding pressure drop across the filter bags. The DCT1000/DCP control automatically activates the cleaning cycle when the DCT1000's pre-programmed set points have been exceeded. This on-demand control system alleviates excessive air compressor usage by preventing unnecessary cleaning which lowers energy and maintenance costs.

pressure

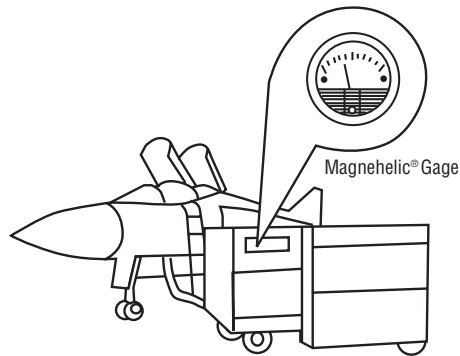

Military flight line air-conditioning system utilizes a Dwyer gage to monitor filter condition.

The extensive avionic systems on modern military aircraft require cool, conditioned air to remove heat generated by this equipment. In flight, the cooling air needs are met by the ambient air at higher altitude. However, during pre-flight maintenance, the high volume of cooling air must be supplied by easily transportable air conditioning systems like the unit illustrated above. Critical monitoring of the condition of the air must be supplied by easily transportable air conditioning systems like the unit illustrated above. Critical monitoring of the condition of the air filters used on these portable systems is provided by the Dwyer Magnehelic® gage. The Magnehelic® gage easily meets the reliability and ruggedness requirements of this application.

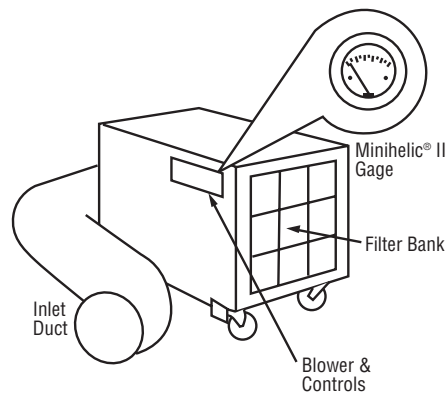

Differential pressure gage monitors filter loading in asbestos removal negative air system.

Removal of asbestos material from buildings requires careful containment of airborne fibers generated during the removal process. The work areas must be sealed off and maintained at a negative pressure compared to atmosphere to prevent the escape of fibers from the work area. The negative pressure air system illustrated above is portable and contains a HEPA filter to remove the asbestos fibers from the “suction” duct prior to exhausting the resulting clean air outside the work space. A Minihelic® II differential pressure gage is utilized to monitor the pressure drop across the filter bank and indicate when cleaning or replacement is necessary. A Series 1910 differential pressure switch is also sometimes used in parallel with the gage to activate a filter alarm lamp mounted on the system control panel.

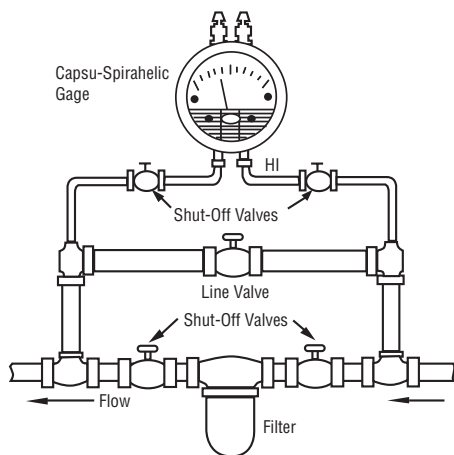

High pressure gage monitors condition of pipeline liquid filter.

In a typical high pressure liquid filter installation, a clean filter element will have a rated pressure drop for a given operating line pressure and rate of flow. As the filter accumulates particulate, the resistance to flow increases and the pressure drop increases until the level is reached when the filter element must be cleaned or replaced. The Capsu-Spirahelic gage will indicate the differential pressure across such filters up to 100 psig. The by-pass piping and valving permit changing either the filter or the gage without shutting down the system.

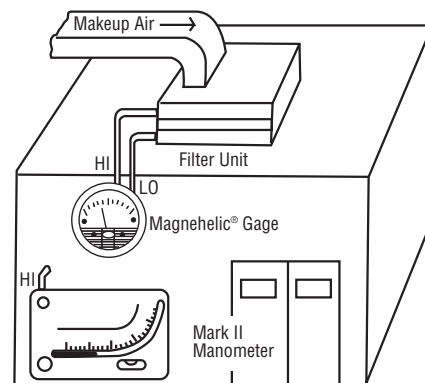

In pressurized hospital rooms, a Dwyer manometer reveals pressure while a Dwyer gage monitors air filter.

Hospital patients who are susceptible to dust or bacteria require the services of an “environmental care unit.” Sophisticated air filtration systems remove particulates from the incoming pressurized air. A Magnehelic® differential pressure gage monitors the pressure drop across the filter system to indicate when maintenance is necessary. The Dwyer Mark II manometer monitors positive room pressure to insure that adequate pressure above atmospheric will prevent an influx of unfiltered air when the doors are opened. If a dial type readout is desired, a Magnehelic® or Minihelic® differential pressure gage can be used in place of the Mark II manometer. Or, to provide a visual or audible warning of impending problems, Photohelic® switch/gages can be installed to serve both applications.

pressure/flow

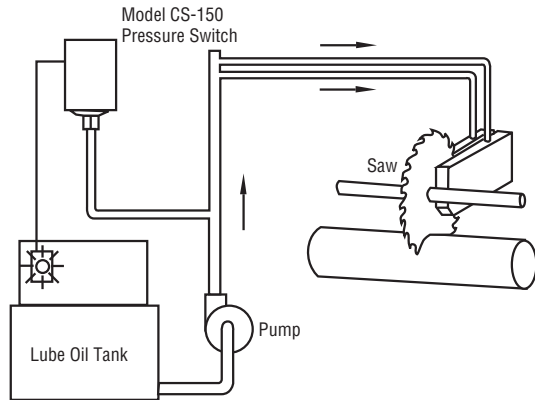

Mercoid® model CS-150 pressure switch senses loss of lubricating oil to saw blade in saw mill and actuates an alarm.

Since only a small amount of oil is used, the sawdust can be recovered and used as a fuel. The pressure switch (CS-150) sounds an alarm if the oil pressure is lost, preventing severe damage to the saw blade.

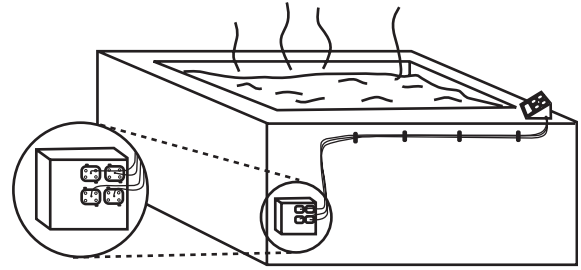

Miniature pressure switches ensure safe electronics in spas and hot tubs.

Control panels on hot tubs and spas must have their electronics completely isolated from any point where water could enter the system; however, control buttons must be easily accessible for proper operation. To accomplish this, pneumatic buttons are used, which when depressed, transfer a pressure through a tube to a Dwyer MDA or MDS Miniature Pressure Switch. When the switch senses the pressure, the circuit closes, sending a signal to the control panel to perform the intended function. As such, electronic components can be located in a safe, water-free area of the system.

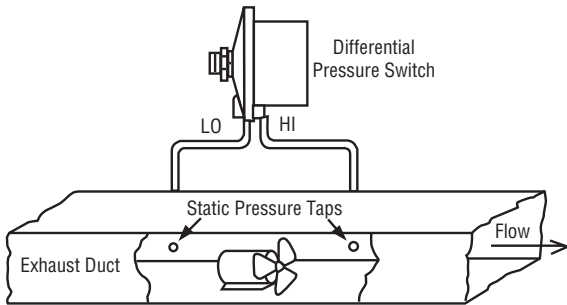

Dwyer differential pressure switch monitors fan operation.

Where it is necessary to prove operation of an exhaust fan, a Dwyer differential pressure switch performs well. The simplest technique requires connecting only the high pressure switch port to a static pressure tap downstream from the fan, if the fan is located at the beginning of the duct, or the low pressure port upstream from the fan if the fan is located at the end of the duct. The switch senses the slight pressure created by the fan compared to the atmosphere. If the fan is located somewhere within the duct, we recommend placing sensors ahead and behind the fan, as shown above. This takes advantage of the higher pressure differential across the fan to operate the switch. In all three cases, if the fan stops, the switch will signal a warning or start auxiliary equipment.

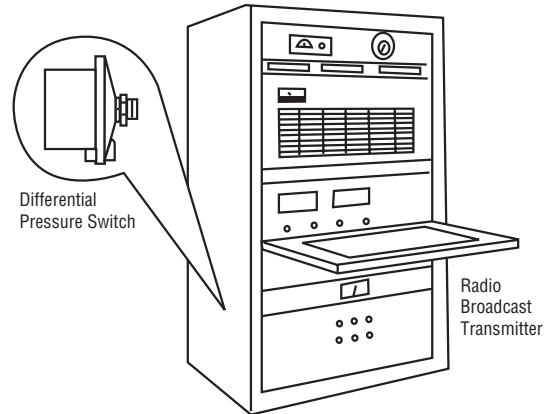

Dwyer switches protect electronic equipment should cooling air flow fail.

Dwyer differential pressure switches are specified to prove the existence of sufficient cooling air flow in electronic equipment. Large final amplifier tubes in broadcast radio transmitters require essential cooling air or overheating will quickly damage these expensive components. A total pressure pick up placed in the cooling air stream and connected to the pressure switch can instantly sense any drop in total pressure due to fan failure or air blockage. It will then sound an alarm or shut down the amplifier before failure occurs or temperature sensors cause a less desirable shutdown.

flow/air velocity

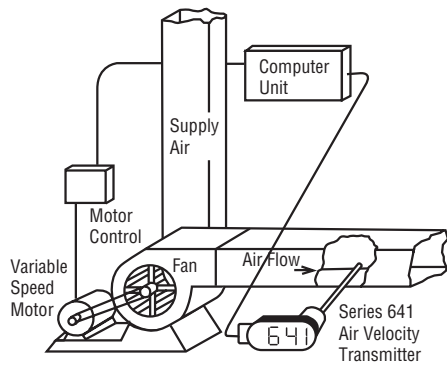

Dwyer transmitter signals precise air velocity adjustments to computer-controlled variable-speed fan motor.

In variable air volume (VAV) HVAC systems, a computerized control provides precise adjustment of air volume to meet changing system needs with maximum energy efficiency. The Dwyer Series 641 has an optional LED display for local indication of air flow. The LED display provides a quick, visual acknowledgement of proper system performance. The computer reacts to any change in velocity by signaling the motor control to increase or decrease fan speed to maintain the required velocity. The computer, taking inputs from other ambient condition sensors, will establish a new required air velocity and signal an appropriate adjustment in fan speed.

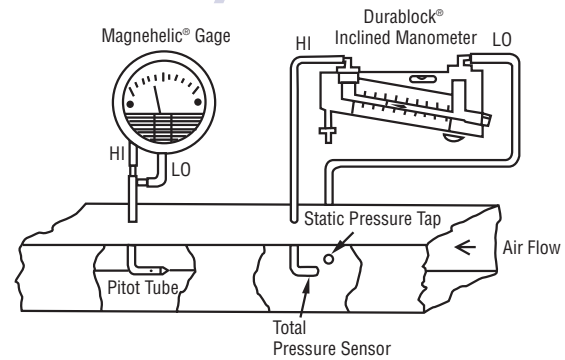

Either of two methods used to measure air velocity.

To measure air velocity, connect a Dwyer Magnehelic® or Minihelec® differential pressure gage, or a Dwyer Durablock® inclined manometer to a Pitot tube in the air stream as shown. The alternative method at right requires only a static tap plus a simple tube in center of duct to pick up total pressure. The differential pressure reading on the gage or manometer is velocity pressure, which may be converted to air velocity by calculation or reference to conversion chart. Where air density is known, the gage manometer can also be calibrated directly in velocity units. If you need an alarm or control function to maintain a preset air velocity limit, install a Photohelic® switch/gage. Dwyer stainless steel Pitot tubes are made in numerous lengths and configurations to serve in the smallest to the largest duct size.

air/gas

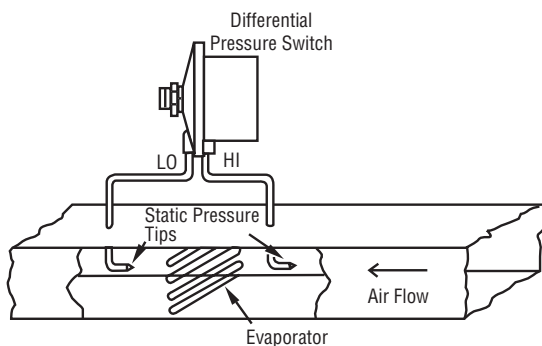

Dwyer switch senses ice build-up on cooling coils and actuates defrost cycle.

In this cooling application, the Dwyer differential pressure switch senses the increasing restriction to air flow caused by icing and actuates the defrost cycle. Two static tips are installed to sense the differential pressure across the cooling coils. In a low cost, low voltage and current, high volume product application, the Dwyer Minifactor® differential pressure switch is an economical unit to specify for this type of application. Dwyer offers six types of stainless steel static tips to suit any application. In service applications, the Dwyer Trail-Tail® static pressure sensor serves to take accurate static pressure measurements, as it automatically aligns with duct air flow. The Trail-Tail® sensor, when attached to a length of light tubing, can also be used to take measurements downstream from the point of access to the duct.

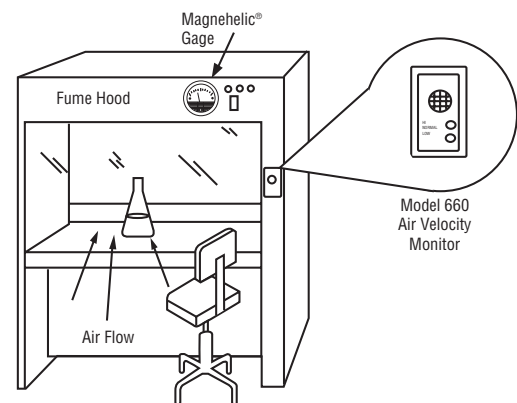

Ensure proper ventilation by continuously measuring fume hood face velocities.

The Dwyer 660 Air Velocity Monitor continuously measures fume hood face velocities to ensure proper ventilation in accordance with safety standards. An audible and visual alarm alerts the user when the lowest allowable safe operating limit of the fume hood has been reached. The 660 has an adjustable low limit range of 0-150 FPM (0-0.792 m/s) which allows the alarm point to be set in accordance with the proper agency safety standards. These cabinets often feature a Magnehelic® differential pressure gage on the control panel to monitor static pressure in the system as a check on proper blower operations and to monitor pressure drop across the filter to indicate when the filter should be serviced or replaced.

flow/air velocity

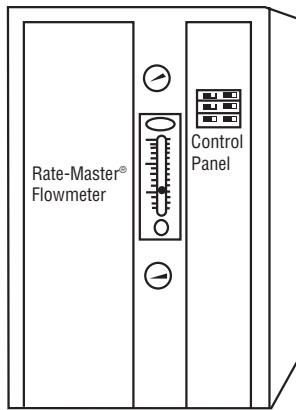

Air delivery source for telephone cables monitored by Dwyer flowmeters.

Telephone cables, both overhead and underground, are pressurized with dry air to increase the reliability of communications by protecting the cables from moisture. This compressor/dryer system utilizes a Dwyer RMB Series flowmeter to indicate the percentage of total system air capacity being delivered to the cable routes connected to the dryer.

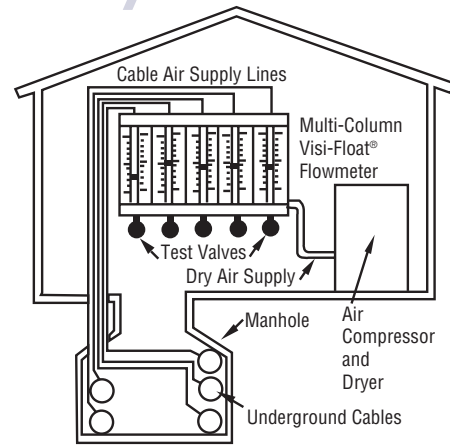

Flowmeters used to check dry air flow protecting cables.

Underground telephone cables are kept under pressure with dry air for protection of the electrical circuits against damage due to moisture. The flow of air to each cable is monitored to determine proper protection as well as to detect leaks that may develop due to cable damage. Special multi-column Dwyer Visi-Float® flowmeters are widely used in this application. A manifold bored in the flowmeter bank connects the supply air to the bottom of each flowmeter through an on-off valve located in each bore. The outlet of each flowmeter then feeds a single cable.

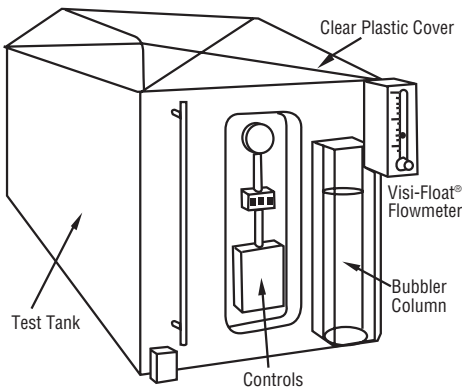

Salt corrosion test cabinet includes a Dwyer flowmeter for adjustment of bubbler air flow.

Prior to atomizing a heated salt solution to produce a fog inside this corrosion test cabinet, compressed air is bubbled through a heated water column to properly heat and humidify the air. A Dwyer Visi-Float® VFA flowmeter, as part of the system, provides precise adjustment of the bubbler air flow to meet test standards.

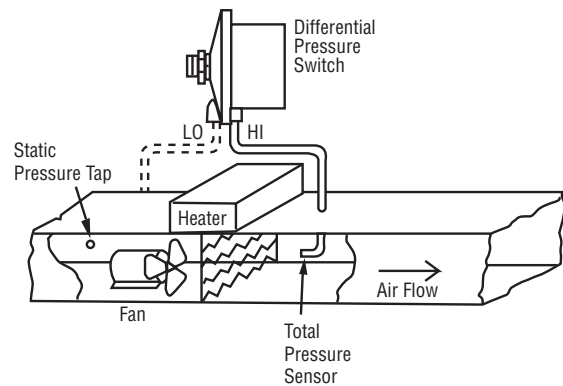

Dwyer switch protects duct heater if air flow fails.

Sensing total pressure (velocity plus static), the Dwyer Differential pressure switch in this application turns off the duct heater to prevent burning out the heating element if the air flow across the element becomes insufficient. In some cases, it may be necessary to sense the negative static pressure upstream from the fan (dotted lines) to develop a large enough differential pressure signal to operate the switch reliably.

flow/air velocity

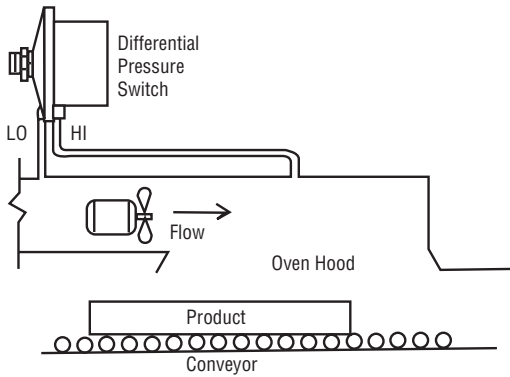

If oven air flow fails, a Dwyer switch stops the process.

In this conveyor fed oven, a differential pressure switch monitors the pressure increase across the fan to assure maintenance of proper air flow. The switch signals a warning or stops the process upon failure of the fan. A second differential pressure switch in parallel - and set for a higher pressure - can provide more complete protection by sensing the greater pressure drop that would result from blockage of the air intake. To add a capability for continuous visual monitoring by the operator, install Dwyer Photohelic® switch/gages for these functions.

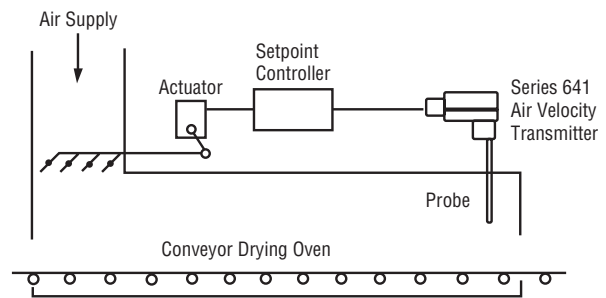

Air velocity transmitter controls drying oven air flow.

The flow of heated air is held to a constant predetermined velocity in this carefully controlled low temperature process drying oven. The constant temperature air supply is modulated by a set of inlet louvers operated by a servo-driven actuator. A Dwyer Series 641 Air Velocity Transmitter has an optional LED display for local indication of air flow. The LED display provides a quick, visual acknowledgement of proper system performance. The controller compares the Series 641's signal to the setpoint in the controller and continuously signals appropriate louver adjustments to the actuator.

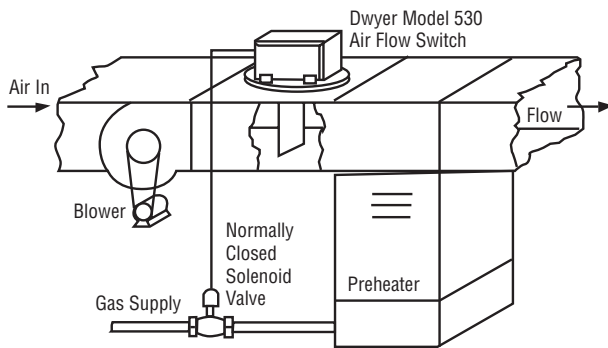

Air flow switch protects preheater from overheating.

Dangerous overheating would occur in this gas-fueled air preheater if the blower fails or the air flow is obstructed. To protect against this condition, a Dwyer Model 530 air flow switch wired to the gas supply solenoid valve will close the valve if the air flow fails. A normally closed solenoid valve is specified to provide for fail-safe operation of this protective system. Where hazardous ambient conditions exist, a W.E. Anderson® Model V4 Flotect® explosion proof flow switch can also be used. In addition, a Mercoid® Model M-51 temperature switch can be used to monitor preheater temperature.

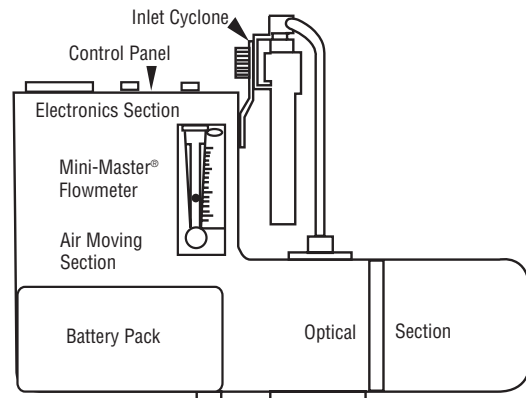

Operator uses Mini-Master® flowmeter to verify air flow into portable dust monitor.

The small size, accuracy, and low cost of the Dwyer Mini-Master® Series flowmeter lends itself perfectly to use in this portable, battery-operated dust monitor. Using a light scattering electronic sampler, a small vacuum pump draws air through the flowmeter into the sampling chamber, and the flowmeter verifies the proper volume of sample air flow. Readout is digital and directly in dust weight per cubic meter of air.

flow/air velocity

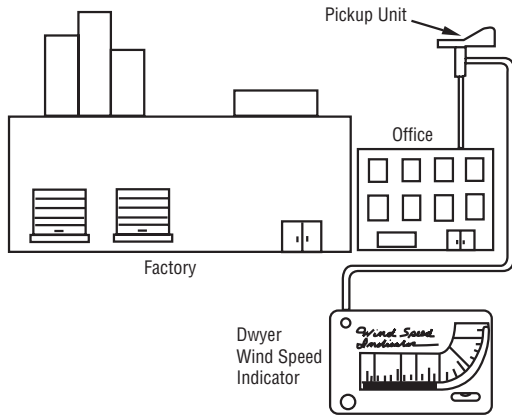

Dwyer Wind Speed Indicator is widely used in homes, offices, factories, marinas and farms.

The Wind Speed Indicator is a low-cost but durable unit for measuring wind speed. It includes a remotely located indoor readout instrument. It incorporates a simple, roof-mounted Pitot-tube type sensor and a low-cost inclined-vertical manometer. No electrical power is needed - neither external, wind generated or battery. Solidly made, the Wind Speed Indicator has been known to continue functioning in extreme wind and weather that destroyed other mechanical-electrical devices. Wherever the velocity of the wind in either MPH or KPH is required - at home, office, factory, farm or remote sites - the Wind Speed Indicator is highly useful.

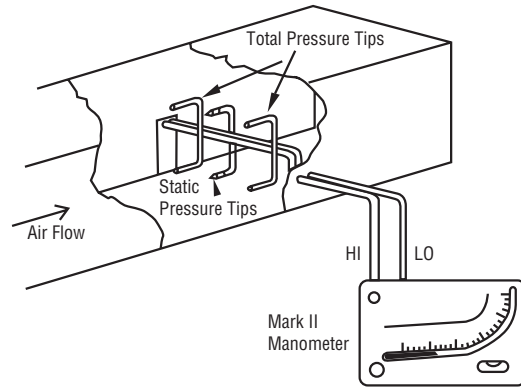

Permanent stations indicate air velocity round the clock.

The efficient operation of heating and air conditioning systems depends on delivery of balanced, pre-determined air flow. Permanent measuring stations installed in the ducts enable plant engineers to locate and correct problems before they affect efficiency. Such stations can use low-cost Dwyer Mark II manometers to indicate velocity pressure directly as the differential pressure between averaging total and static pressure tips. The manometer is calibrated directly in CFM, as the duct area of the station is known. A dial type Dwyer Magnehelic® differential pressure gage can be used as an alternative if preferred.

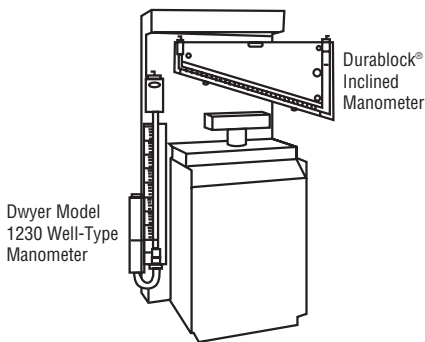

Engine component test flowbench utilizes precision Dwyer manometers to measure test pressures and air flow.

This self-contained flowbench is used to test internal combustion engine components such as cylinder heads, intake manifolds, throttle bodies, air cleaners, etc., for design changes to achieve maximum air flow and minimum pressure drops through critical flow passages. Flow changes as small as 0.5% can be measured. A Durablock® inclined manometer, indicating percent of flow, is utilized in conjunction with individualized calibration charts to determine air flow in CFM. Two 48" Model 1230 well type manometers are also employed, one to set and monitor test pressure and the other one for port mapping or auxiliary use. These Dwyer manometers offer the necessary resolution and accuracy to determine the effects of small changes in engine design needed to achieve maximum performance.

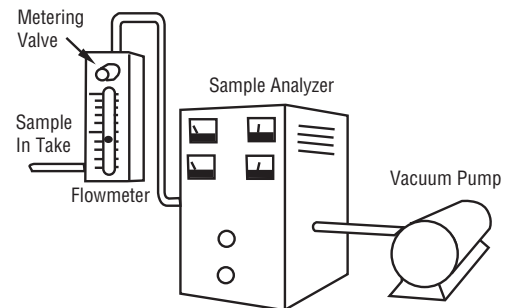

Metering valves on Dwyer flowmeters control air/gas intake on permanent air pollution analyzers.

Regulations regarding air pollution levels require continuous monitoring a source and ambient pollutants in areas where noxious gases are generated. Ambient air quality samplers utilize either Visi-Float® or Rate-Master® flowmeters to establish the proper flow of sample or carrier gases into the analyzer. Top mounted metering valves are recommended for flowmeters used in vacuum service to maintain specified accuracy.

flow/air velocity

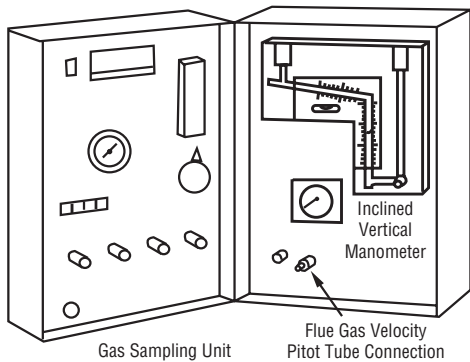

Portable sampler includes Durablock® manometer for accurate measurement of stack gas velocity.

Stack sampling regulations aimed at compliance with air pollution standards as well as the practical need for energy conservation require the use of many different instruments to make the appropriate measurements. A special Dwyer Durablock® dual column inclined/vertical manometer is used in the control unit of a portable particulate sampler which can perform all the required tests and measurements. While the illustration above does not fully represent the complexity of this instrument, the manometer's primary function is accurate measurement of the gas velocity in conjunction with a Pitot tube assembly in the stack probe.

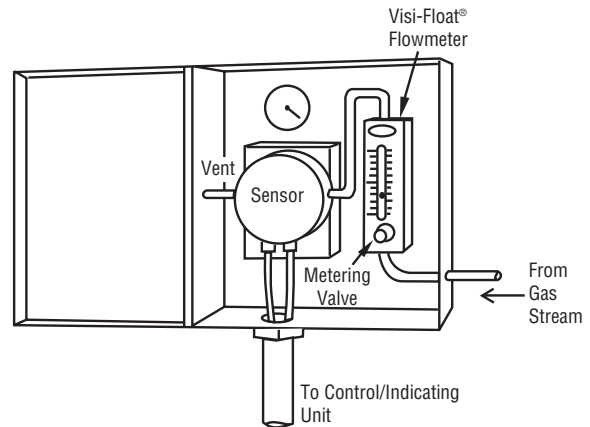

Instrument for monitoring dew point in gas streams uses flowmeter with metering valve to control gas.

A chilled-mirror sensor system provides a continuous monitoring of dew point in various gas streams or humidity chambers. The sample flows into the sensor under pressure with the proper flow rate set by the metering valve on the Dwyer Visi-Float® flowmeter.

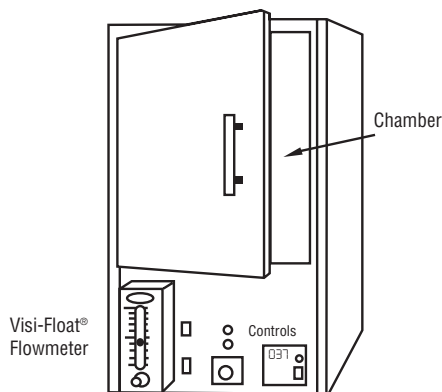

Designers of a bio-medical incubator rely on a Dwyer flowmeter to control CO₂ flow.

This low temperature incubator with CO₂ atmosphere is used in bio-medical applications, such as short term blood work and long term tissue culture studies. CO₂ is introduced at a high initial purge rate controlled by a timer. After the purge period, a Dwyer Visi-Float® flowmeter with a metering valve is utilized to adjust and monitor the CO₂ flow in cubic centimeters per minute. The Visi-Float® flowmeter provides the reliability and accuracy needed to complement the host of high performance features designed into this incubator.

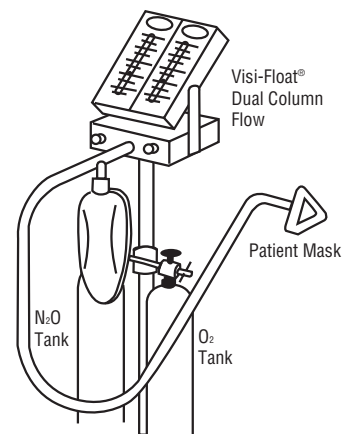

Durable dual-column flowmeter adds value for physicians and oral surgeons.

Physicians and oral surgeons who use anesthesia or analgesia in their offices on an occasional basis require a system that is reliable but small and portable. One such system employs special Dwyer dual-column Visi-Float® flowmeters to meter and monitor precise flows of nitrous oxide and oxygen to the patient. In addition to meeting the performance level demanded by this application, the Visi-Float® flowmeters are durable and attractive complements to this important and visible medical device.

flow/air velocity

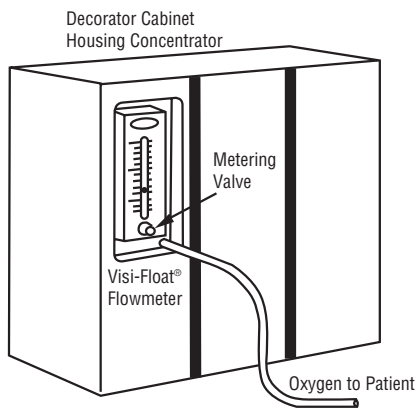

Oxygen concentrator replaces heavy tanks and includes Dwyer flowmeter for easy adjustment of oxygen flow.

Eliminating the need for cumbersome oxygen tanks, an oxygen concentrator delivers oxygen to the patient from the surrounding air. This is a great convenience and cost savings for those who frequently require oxygen at home. A Visi-Float® or Rate-Master® flowmeter with a metering valve is placed in the oxygen output line, so the patient can easily adjust the flow to the prescribed level.

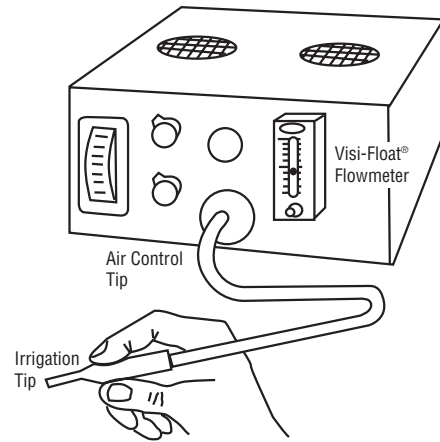

Designers of a medical irrigation unit specified a Dwyer flowmeter to control heated or cooled air flow.

Heated or cooled air is used for irrigation in certain medical procedures. Precise control of air flow, temperature, and time is required. The manufacturers of a device to provide this service rely on a Dwyer flowmeter to adjust and monitor air flow to the irrigation tip from the pump located in the unit.

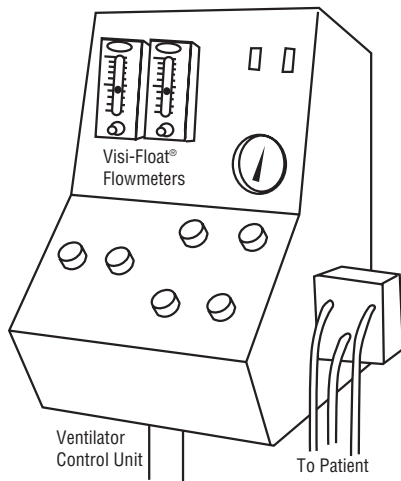

Metering valves on Dwyer flowmeters control precise mix of oxygen and air for infant ventilator.

Dwyer Visi-Float® flowmeters are specified to monitor and control the mixture of oxygen and air supply by an infant ventilator. Special scales and oxygen cleaning customize the flowmeter to this application. The built-in metering valve allows precise setting of flow for each gas.

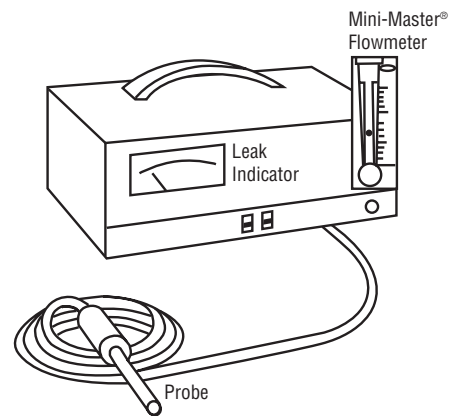

Small Dwyer flowmeter reveals proper suction flow into portable halogen leak detector.

This portable detector pinpoints halogen leaks as the operator probes suspected areas and observes the leak indicator. A Mini-Master® flowmeter provides a low-cost means of continuously checking that proper suction flow is maintained by an internal pump, so that leaks do not go undetected due to obstruction of the probes or failure of the pumping system.

flow/air velocity

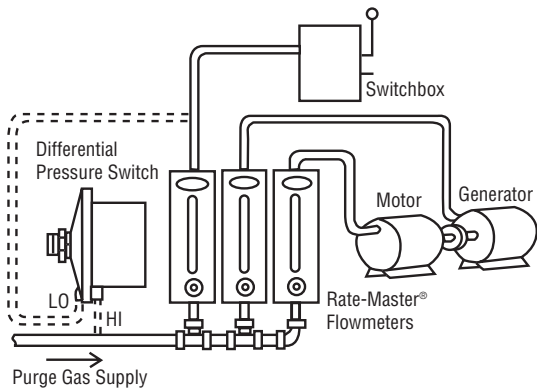

Flowmeters and/or differential pressure switches monitor vital purge gas flow to motors, switchgear, instruments.

To purge motors, generators, switchgear, and industrial instrument cases, Dwyer flowmeters are installed in the supply line to indicate a flow of air, manufactured inert gas, or nitrogen to these devices. The flowmeters (with valves) allow maintenance personnel to set the flow quickly and recheck anytime to make sure proper flow continues. A Dwyer differential pressure switch can also be used to monitor proper flow on a continuous basis and provide a signal or alarm if purge gas flow fails. Such an optional switch is shown above, monitoring proper flow of purge gas to the switchbox as a function of pressure drop across the flowmeter. The purging of electrical equipment in hazardous areas may require more extensive control and monitoring devices.

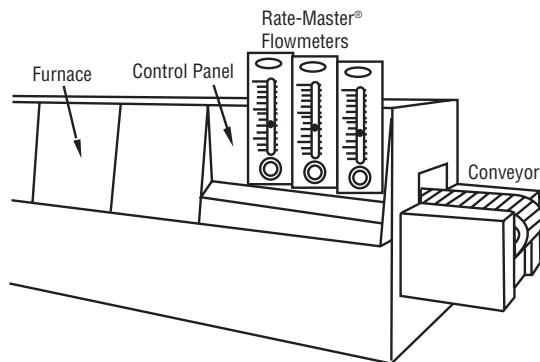

Flows of air and gases used in a special furnace are controlled by Dwyer flowmeters.

A total of eleven Dwyer Rate-Master® flowmeters function in the design of this sophisticated conveyor belt furnace used in manufacturing electronic devices. The flowmeters provide precise adjustment and monitoring of the flows of air and gases into the various portions of the furnace, which allow it to perform different operations, such as decarburizing and oxidizing, metallic package sealing, glass package sealing, and glass-to-metal sealing.

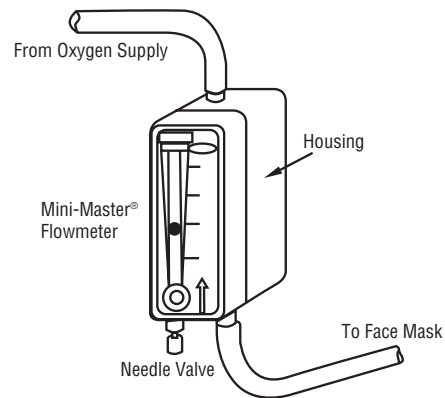

Oxygen supply in small aircraft controlled by a compact Dwyer flowmeter.

The Mini-Master® flowmeter is ideal for this small in-line oxygen flowmeter used to set and indicate proper flow of oxygen to pilots and passengers flying at higher altitude in small aircraft. To conserve oxygen and reduce the drying effect of excess oxygen on the nose and mouth, the exact required flow can be set using this device. The user simply holds it in a vertical position and adjusts the needle valve on the Mini-Master® flowmeter for a float position equal to the flight altitude. The needle valve and flowmeter connections are contained in the small housing. The entire unit can hang from an overhead oxygen outlet by the connecting tubing or dangle in any position after proper flow has been set.

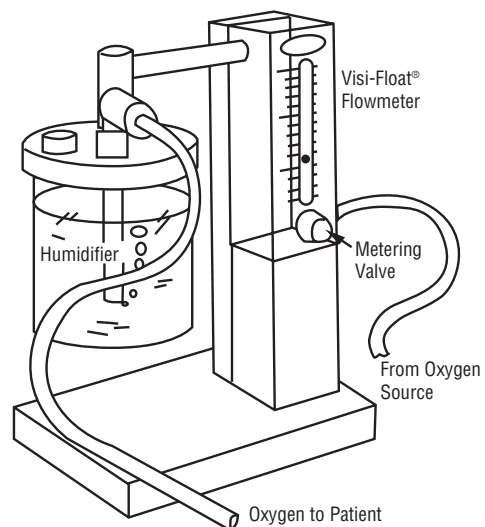

At-home patients can set metering valve on a flowmeter to deliver needed flow of humidified oxygen.

A portable device that meters and humidifies oxygen required by a patient at home also provides convenience of movement away from the oxygen source. A Visi-Float® flowmeter with a metering valve allows the patient to see the prescribed flow. This flowmeter's small size and light weight, as well as its smart appearance, make it well suited to the portability requirements of this device.

flow/air velocity

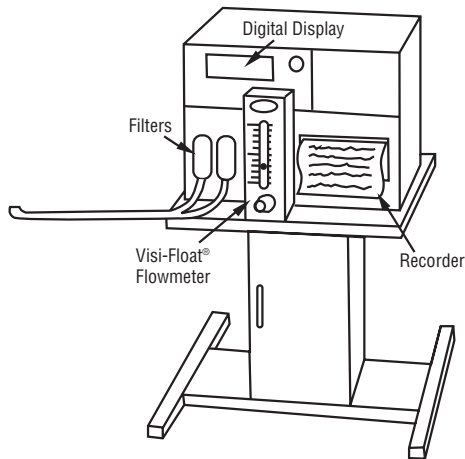

Patient breath sampler uses Dwyer flowmeter to adjust flow rate of expiration breath sample.

Continuous monitoring of the CO₂ in the expiration breath of a patient in intensive care or under anesthesia provides a rapid indication of changes in metabolism due to respiratory or circulatory problems. The designers of this monitoring device specified our Visi-Float® flowmeter to permit adjustment of the proper breath sample flow rate induced by a vacuum pump in the monitor.

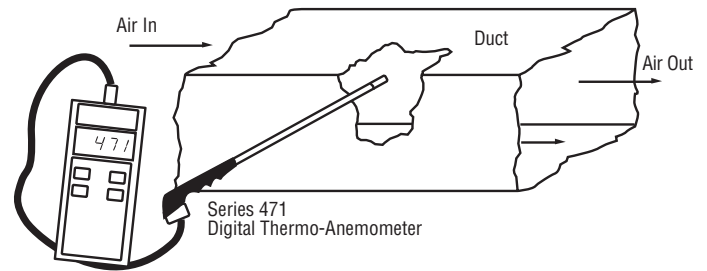

Determine air velocity and temperature levels in ducts or air supply grills.

The Dwyer Series 471 Digital Thermo-Anemometer is the ideal portable product for determining air velocity and temperature levels in ducts or air supply grills. The 471-1's versatility is due to its four field selectable ranges from 0-500 fpm (0-3 MPS) up to 15,000 FPM (70 MPS). With a push of a button, FPM and Fahrenheit readings are converted to MPS and Celsius. Readings may be stored and retrieved which allows the user greater efficiency with HVAC balancing at various locations in a building.

Model 471-2 has an extendable probe and model 471-3 provides a bendable extending probe for hard to reach sampling locations.

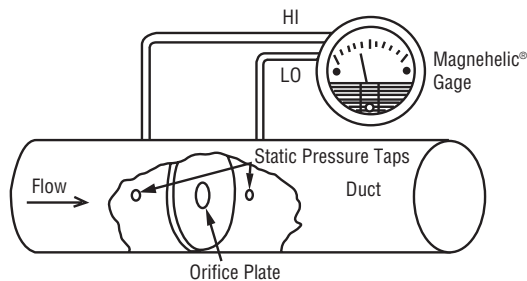

Measuring air velocity with an orifice plate.

In this set-up, the Magnehelic® gage measures higher air velocities as a function of the pressure drop across a sharp-edged orifice plate in the pipe. The pressure drops can be converted to air velocity using orifice plate data supplied by the manufacturer. Details regarding available sizes, ranges, installation, and limitations are available from orifice plate manufacturers and from standard handbooks. A Dwyer Durablock® inclined manometer or Photohelic® differential pressure switch/gage can also be used. In addition to the visual reading gage, the Photohelic® switch/gage provides an alarm signal or shutdown control function. Pressure sensing taps should be located on the side or top of the pipe or duct to prevent condensation from draining into sensing lines or gages.

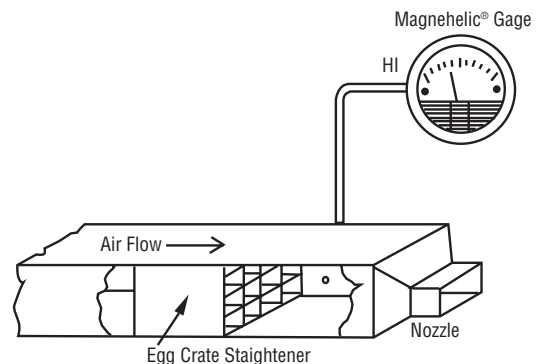

Measuring velocity or volume of air flow in duct.

A small flow nozzle with an egg crate air straightener located upstream in a large duct provides an accurate, easily constructed air velocity measurement system. Air velocity distribution at the point of discharge across the outlet of nozzle is uniform, and static pressure is zero (atmospheric). Consequently, in the low flow area upstream from the nozzle, static and total pressure at nozzle outlet. As a result, the air velocity and/or volume of flow is easily calculated. The Dwyer Magnehelic® differential pressure gage or manometer can be calibrated to read air velocity or volume directly - assuming standard or constant air density (i.e. temperature, humidity, and pressure). A Photohelic® switch/gage can be used if an alarm or control function is required at a given air velocity or volume.

flow/air velocity

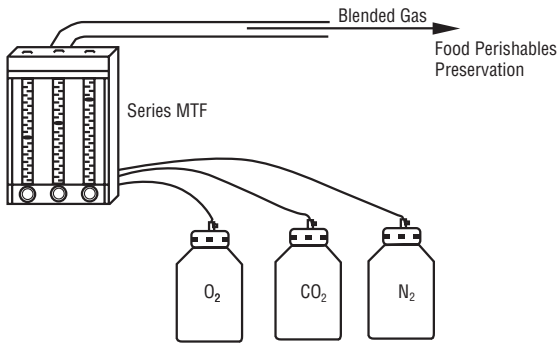

Enable accurate metering of gases in preservation of food perishables with Dwyer Multitube Flow System.

For blending or metering different gases, Dwyer's MTF Multitube Flow Systems are some of the industry's most reliable and requested products. Food packaging is one of many applications which require precise mixing of several gases. Oxygen, N₂, CO₂, and other gases are blended and injected into the packaging of perishable products to optimize the shelf life. The gas mixture replaces the previously evacuated air, providing the necessary preservation. By merging high precision valve technology with flowtubes that can be correlated to almost any gas, the proven design of the MTF imparts accurate gas measurement and control.

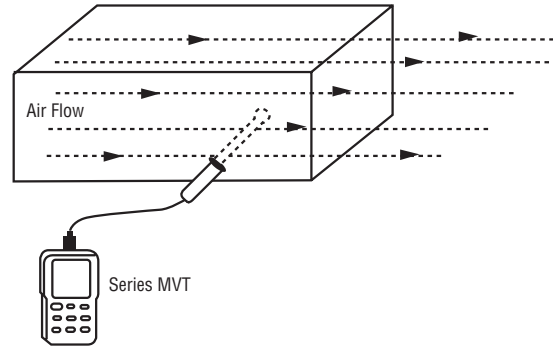

Handheld anemometer enables traversing duct flow measurements with a miniature vane and telescoping probe.

Handheld anemometers are an excellent, portable tool for performing tests on HVAC system performance; however, large rotating vanes can prevent easy access to ducts. Dwyer introduces the MVT Mini-Vane Thermo-Anemometer to eliminate this problem. With its 1/2" diameter vane, the MVT simplifies probe entry into the duct. Traversing measurements, which are difficult or impossible with other anemometers, are made easy with the MVT's telescoping, extendable probe. Additionally, simple keypad programming enables the user to view volumetric flow rates in CFM or CMM. Datalogging software is also available to easily record and view data on a PC or laptop.

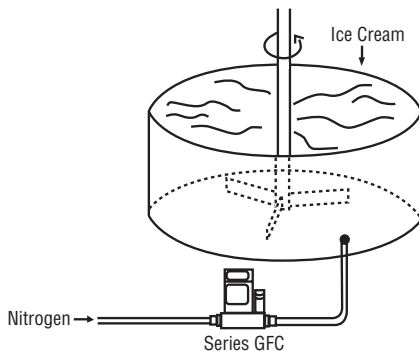

Provide simple, accurate flow control of various gases for many applications with a Gas Mass Flow Controller.

Dwyer GFC Gas Mass Flow Controllers are ideal for numerous applications where high accuracy gas flow control is required. Ice cream producers must generate an exact 50% air-to-cream ratio in order to comply with federal regulations. The GFC can measure the mass of air injected into the mixture, freeing operators from lengthy and potentially inaccurate procedures involving volumetric meters with manual valves. Dwyer GFC's are equipped with precision valves which can be controlled locally by an operator or remotely using industry standard analog signals. The controller also outputs an analog signal proportional to the flow rate for remote monitoring purposes.

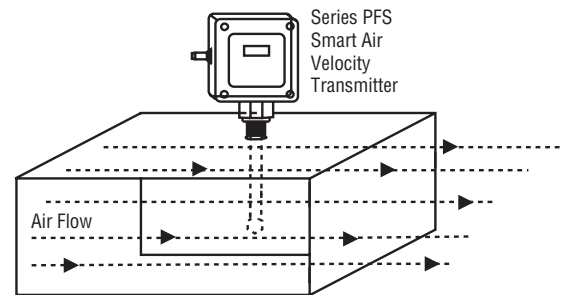

Eliminate the need for Pitot tubes, static pressure tips, orifice plates and differential pressure sensors with a Smart Air Velocity Transmitter.

Installing air velocity measurement systems can be a burdensome process – specifying Pitot tubes, static pressure tips, orifice plates, differential pressure transmitters, etc. Dwyer offers the PFS Smart Air Velocity Transmitter to consolidate these components into one convenient instrument. The PFS can be easily installed into the duct or air stream to accurately measure air flow while providing local indication as well as linear analog output. Microprocessor-based technology ensures accurate, repeatable results while state-of-the-art software allows for volumetric calculations and datalogging functions. The PFS combines these features for simple, reliable airflow measurement without the problems associated with complex, traditional systems.

flow/air velocity

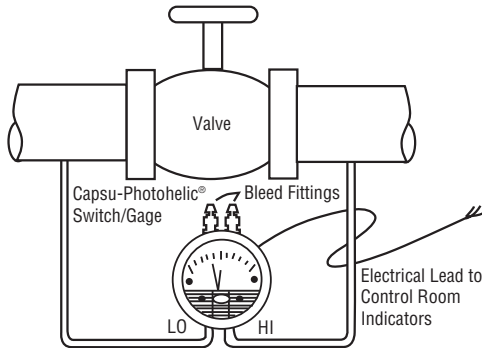

Zero-center switch/gage on pipeline signals flow direction to remote control room.

When used with water or other compatible liquids, a brass body Dwyer Capsu-Photohelic® differential pressure switch/gage serves as a simple, reliable flow direction monitor. It will signal flow direction in a pipeline at a remote location, such as in a control room. Taps in the wall of the pipe on each side of a conveniently located valve provide a method to indicate a small pressure drop due to a slightly restricted flow even when the valve is fully open. A low range zero-center Capsu-Photohelic® switch/gage registers flow in one direction as an upscale reading and opposite flow as a downscale reading. With the set-points adjusted each side of zero and consistent with the pressure drops involved, the switch/gage relay closure provides the required control of the flow direction indicators.

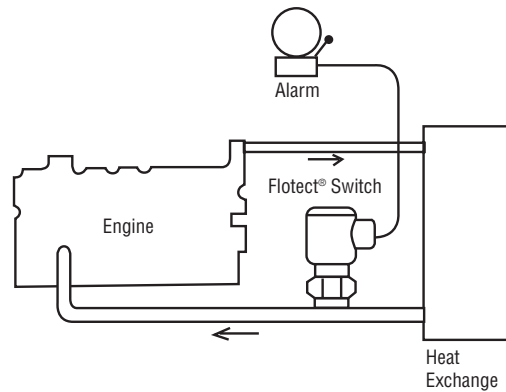

If cooling water flow fails, Flotect® flow switch sounds alarm or stops engine.

To insure the vital flow of cooling water to a large engine, a W.E. Anderson® V4 Flotect® flow switch can be placed in the cooling water line. It will sound an alarm if the flow falls below a safe minimum, or can even be connected to shut off the engine.

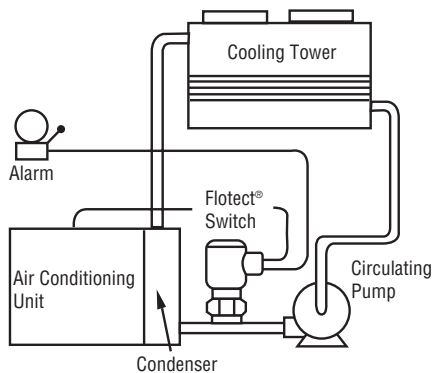

Flotect® flow switch ensures cooling water circulation before air conditioning compressor motor starts.

Large air conditioning and refrigeration systems which include water cooled condensers require that the water must circulate through the condenser and cooling tower in sufficient volume before the compressor is started. Here the W.E. Anderson® Flotect® flow switch is connected to the compressor control circuit to prevent starting or to shut down the compressor control circuit if the flow of cooling water falls below that required for proper operation. A dual Flotect® switch (available as an option) will also trigger a remote alarm to signal the operator of the shutdown as soon as it occurs.

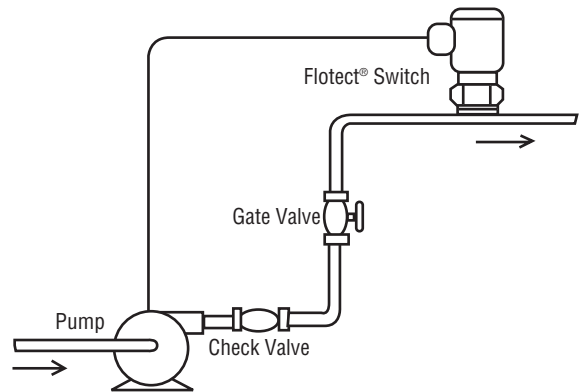

One of many options, a Neoprene boot over Flotect® flow switch vane hinge protects it from buildup of solids.

This W.E. Anderson® V4 Flotect® flow switch has an optional Neoprene boot (inside the pipe) to protect the vane hinge from an accumulation of solids. Installed on a storm sewer lift pump, the switch will stop the pump motor when flow ceases or falls below the set minimum, preventing pump cavitation and wasted power.

flow/air velocity

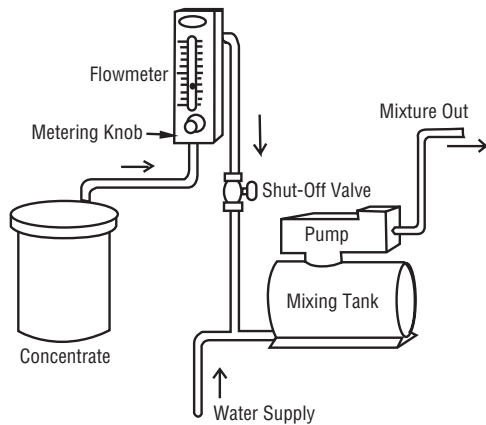

Flowmeter controls flow rate of a chemical concentrate.

When adding a chemical concentrate to a large volume of water or other fluid, you can determine the rate at which the concentrate is being added by using either a Dwyer Rate-Master® or Visi-Float® flowmeter. The concentrate is added on the input side of the pump. This draws the concentrate from its container and also utilizes the mixing action of the pump. While a metering valve is built into the flowmeter, a separate valve permits complete shut-off of the concentrate flow, if necessary, without disturbing the flow rate setting. Typical applications of this set-up include adding medicine to livestock water and detergent to pressure washers or car wash installations. Concentrates must, of course, be compatible with the plastics used in the flowmeter bodies.

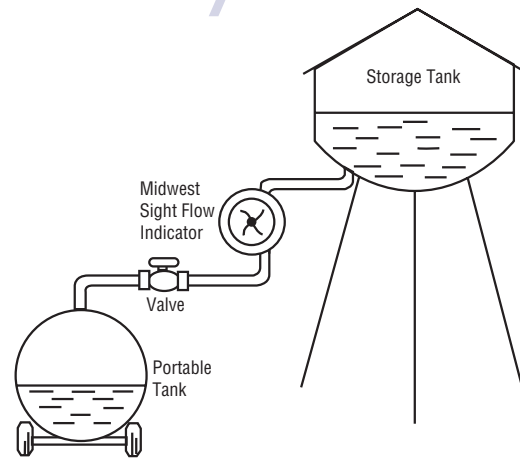

W.E. Anderson® Midwest Sight Flow Indicator reveals flow or stoppage.

In this gravity feed system delivering liquid fertilizer to portable tanks, a Midwest Model 100 sight flow indicator was installed. The operator can see the rotating vanes to check for adequate flow at any time.

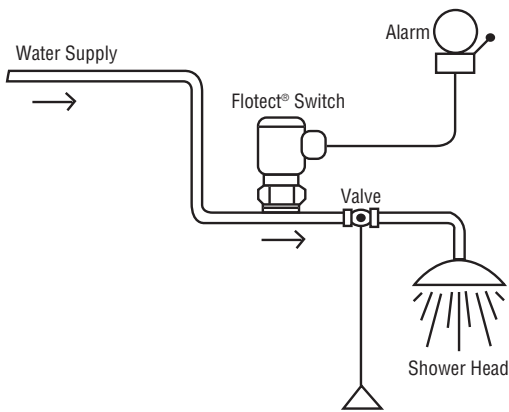

Use of this emergency industrial shower automatically actuates W.E. Anderson® Flotect® flow switch which sounds alarm to bring help.

In this emergency industrial shower, a V4 Flotect® flow switch has been mounted in the water supply pipe. It will activate either an audible or visual alarm (or both) to summon help when the shower is used by an employee who has been accidentally contaminated by hazardous material.

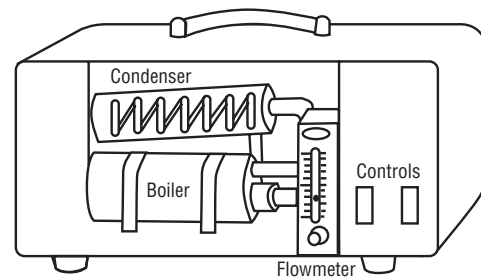

Operators of this laboratory still use the metering valve on a Dwyer flowmeter to set desired feed water flow.

This compact automatic distilling unit provides a small, but continuous supply of ultra-pure water for laboratory use. Using a Dwyer Visi-Float® flowmeter with a metering valve, the operator sets the proper boiler feed water flow consistent with lab requirements up to the rated capacity of the still in liters per hour. When the distillate receiver is full, a level sensor actuates a solenoid valve which shuts off the feed water flow. A Rate-Master® flowmeter can serve equally well in this application.

flow/air velocity

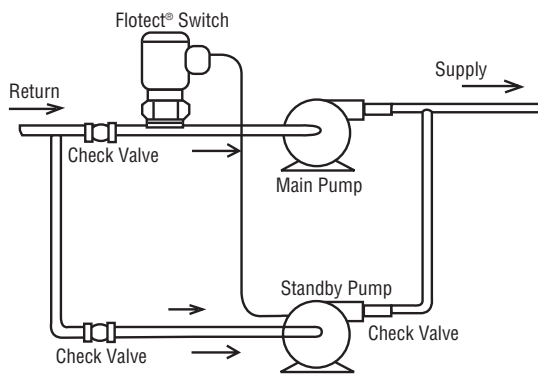

When main pump fails, Flotect® flow switch transfers to standby pump to maintain vital fluid circulation.

When proper fluid circulation in a system is critical, the W.E. Anderson® Flotect® flow switch will automatically start a standby pump should the main pump fail. The flow in the main path of the parallel system illustrated keeps the Flotect® flow switch in an open position. When the main pump fails, the flow will cease. The flow switch then closes, starting the standby pump.

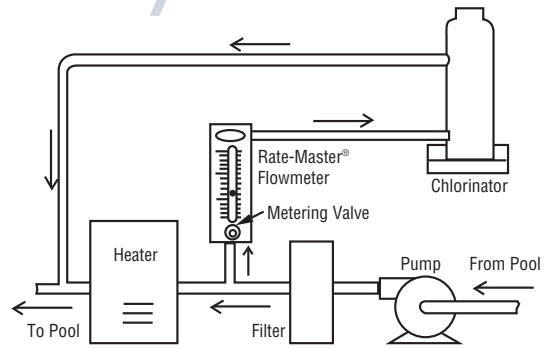

Flow of filtered water to pool chlorinator controlled by metering valve on economical Dwyer flowmeter.

Proper metering of the amount of chlorine added to swimming pool water is necessary to avoid irritation to the swimmer and excessive cost due to using too much chlorine. It also ensures sufficient flow to maintain proper sanitation. A Rate-Master® flowmeter provides a low cost but rugged metering device for this application. Filtered water is tapped from the main pool supply pipe and delivered to the chlorinator at the proper flow rate by the built-in metering valve on the Rate-Master® flowmeter. It then returns to the heated pool water supply line. When using plastic flowmeters such as the Rate-Master® Series for metering chemical solution, try to locate the flowmeter upstream of the chemical additive if possible. This will minimize compatibility problems between the chemical and the plastic body of the Dwyer flowmeter.

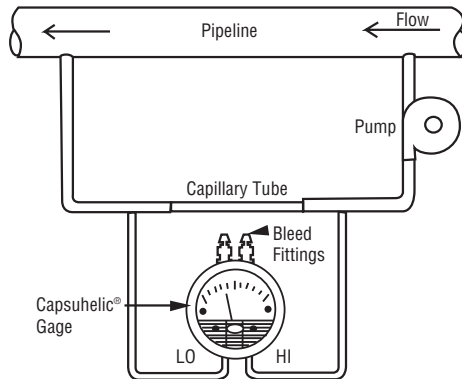

Fuel oil viscosity in pipeline is visually indicated by Dwyer gage or controlled by switch/gage.

Continuous monitoring of fuel oil viscosity is required in some combustion control systems. In this application, a constant flow pump forces a sample of the fuel oil through a capillary tube under temperature controlled conditions. A Capsuhelic® differential pressure gage measures the pressure drop across the capillary and, with the fuel oil at a constant temperature, the gage can be calibrated to read viscosity directly. If automatic viscosity control is desired, a Dwyer Capsu-Photohelic® differential pressure switch/gage will actuate appropriate valve openings and closings electrically.

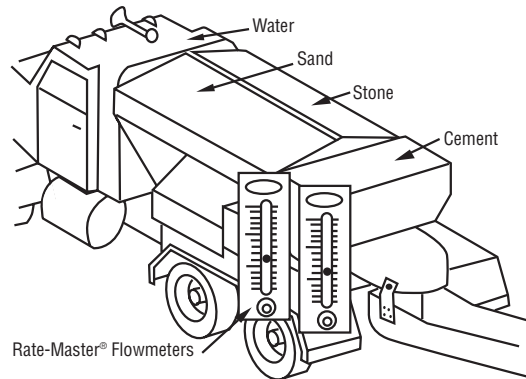

Flowmeters on industrial mixers show flow of special additives.

This mobile concrete mixer transports the unmixed materials to the job site and then prepares the concrete, delivering the exact amount and the proper formulation required for the specific job. On the control panel at the rear of the truck mounted mixer, Dwyer Rate-Master® flowmeters permit setting the proper admixture flows to add the specified quantities of accelerators, retarders, air-entraining agents, etc.

flow/air velocity

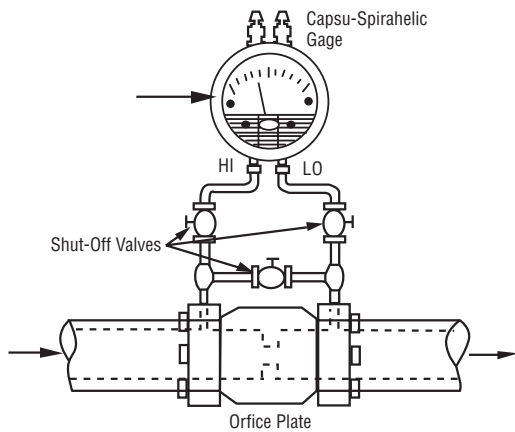

A differential pressure gage measures pipeline pressure drop over orifice plate.

A calibrated orifice plate located in a pipeline will create a pressure drop which can be measured up to 100 psig with a Capsu-Spirahelic differential pressure gage. The pressure drop can be read directly in psig or translated into flow units such as gallons per minute, barrels per day, etc., and read directly on a specially calibrated scale designed to meet customer specifications.

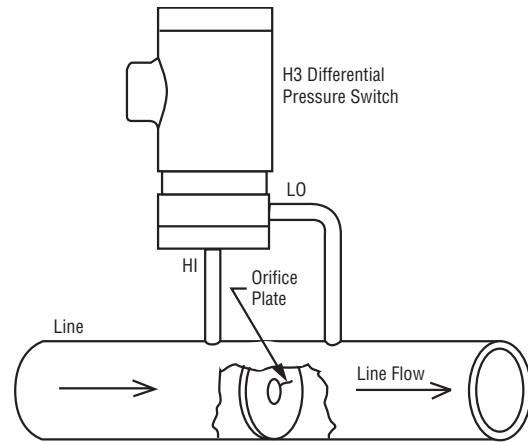

Pressure switch monitors flow in high pressure system.

In a liquid process high pressure line, the process may be adversely affected by flows above (or below) the desired flow. The W.E. Anderson® Model H3 can monitor flow in systems with operating pressures up to 1500 psig as a function of pressure drop across a calibrated orifice plate. The H3 set point is adjusted so that an alarm sounds or the process is automatically shut down if flow exceeds (or falls below) the desired rate.

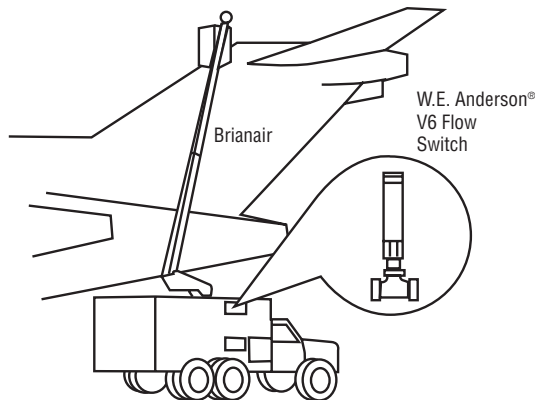

W.E. Anderson® flow switch protects aircraft de-icing equipment.

This aircraft de-icer saves time and heating fuel by heating only the fluid dispensed, not the entire tank. With the de-icing fluid heated by three large heat exchangers operating in parallel, de-icing can begin within 90 seconds regardless of ambient temperature. Three W.E. Anderson® Model V6 flow switches are used to sense adequate flow of de-icing fluid through the heat exchanger, one switch on each exchanger. Should fluid flow be interrupted or drop below a safe level, the burner for the affected heat exchanger will shut down. The V6 flow switch is well suited to this application because of its reliability and inherently weatherproof design.

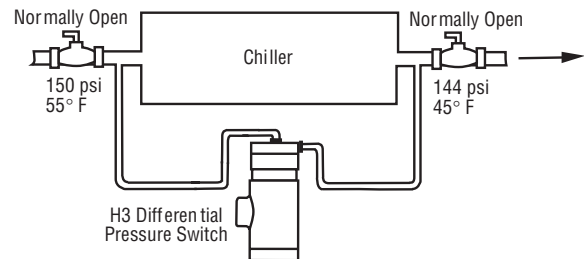

W.E. Anderson® H3 explosion-proof differential pressure switch protects water chiller.

If ice builds up inside water chiller, or if tubes become restricted, differential pressure across chiller increases. Differential pressure switch Series H3 senses the increase and actuates an alarm. Switch is typically set between 10 and 20 psid.

flow/air velocity

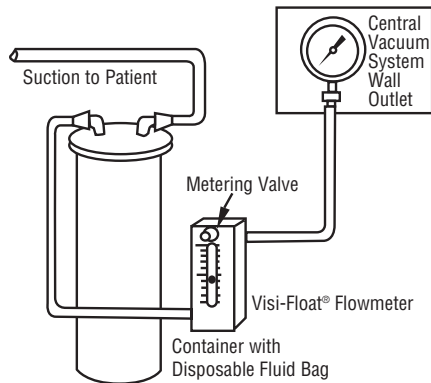

Suction system that removes fluids from hospital patients includes a flowmeter with top metering valve.

Many hospital rooms are equipped with vacuum lines to provide suction for removing fluids from patients. One disposable fluid container system for use with these in-room suction outlets employs a Dwyer Visi-Float® flowmeter with built-in top mounted metering valve. Using this valve, the attending nurse can set the prescribed rate of suction flow for each patient's need. This eliminates the guesswork employed when the wall valve alone is used for flow regulation. Often, the latter can result in either insufficient suction to remove all fluid or tissue damage if too much suction is applied. Top mounted metering valves are recommended for flowmeters used in vacuum service to maintain specified accuracy.

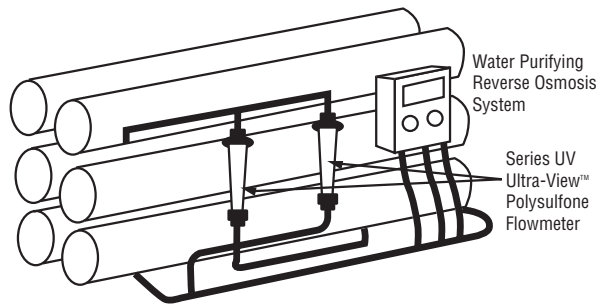

Ultra pure flowmeter for water purification equipment.

The Dwyer Series UV Ultra View™ Polysulfone flowmeter is an industrial, highly accurate flowmeter with excellent physical properties and wetted parts. The Series UV possesses all plastic wetted parts which include polysulfone, Viton®, and PTFE. There are no metal wetted parts that can possibly corrode over time.

Best suited for water purification systems such as reverse osmosis or de-ionized water systems, the Series UV monitors water that is passing through the purifying membranes. Depending on system size, rates may be a few GPM up to 40 GPM or more. Several ranges of the Series UV are available to satisfy these various sizes.

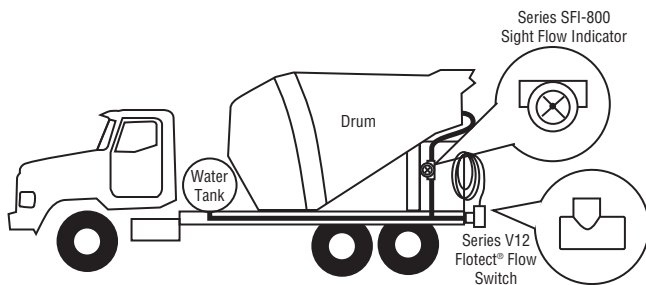

W.E. Anderson® Series SFI-800 and Series V12 indicate water flow in a concrete delivery truck.

Ready mix concrete is delivered in a large truck with a rotating drum that keeps the concrete from hardening. Also on the truck is a tank for storing water that is used to keep the concrete at a proper moisture level. An SFI-800 sight flow indicator and transmitter is installed in the water line between the water tank and the drum to monitor the amount of water added. The SFI-800 has a pulsed output that can be used for flow rate and flow totalization. A display in the cab of the truck allows the operator to monitor the flow from the SFI-800. Also on the truck is a hose line connected to the water tank, which is used to clean the concrete chute and any spills at the construction site. A V12 flow switch is installed in the hoseline to indicate that water is flowing out of that line. The SFI-800 is perfect for this application since it has a weatherproof transmitter package that is removable and replaceable in the field.

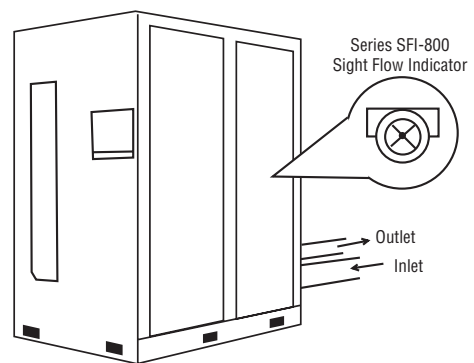

W.E. Anderson® Series SFI-800 indicates water flow in water treatment processes.

The treatment system exposes water to UV (ultraviolet) light that disinfects it. UV light has been shown to kill bacteria and pathogens and has become a viable method for water treatment that eliminates the need to use chemicals such as chlorine. Incorporated into the design of the system is an SFI-800 to monitor the flow rate of the water through the system. The SFI-800 has a visual indication of flow and a linear voltage output of flow rate used to control the flow. Controlling the flow through the system is important to make sure the water is exposed to the UV light the proper amount.

flow/air velocity

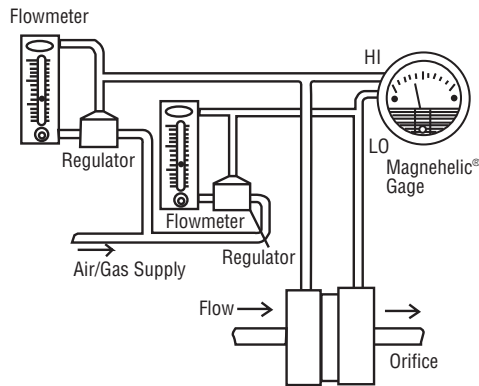

Purging orifice sensing lines with air permits use of a Dwyer gage as an orifice meter on liquid pipe lines.

Dwyer Magnehelic® differential pressure gages can be used as orifice meters in corrosive gas or liquid applications by purging the orifice with air or inert gas under pressure to protect the gage from direct contact with fluid and also prevent clogged meter lines. The gage is shown connected to two Dwyer flowmeters with constant differential pressure regulators supplying purge air or gas to both the low pressure and the high pressure tap lines. Our Photohelic® differential pressure switch/gage can also be used to position motorized control valves using a null band control mode, thus maintaining the proper rate of flow through the pipeline for varying conditions.

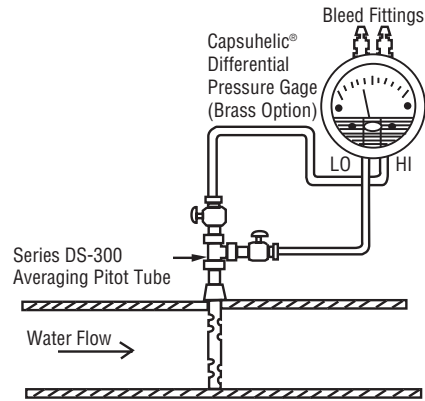

Brass body gage measures water flow rates.

A Dwyer brass body Capsuhelic® differential pressure gage, required for water service to prevent corrosion damage to the gage, is used in conjunction with a Dwyer Series DS-300 averaging Pitot tube. The Capsuhelic® gage provides a basic method of measuring water flow rates. As a guide in selecting the appropriate Capsuhelic® gage range, the designer can consult data provided with the DS-300 averaging Pitot tube. This relates differential pressure in inches of water column to the water flow in gallons per minute for the pipe size involved. The gage can be calibrated directly in GPM if desired. Bleed fittings installed in the top ports of the gage are recommended to facilitate removal of air from the system.

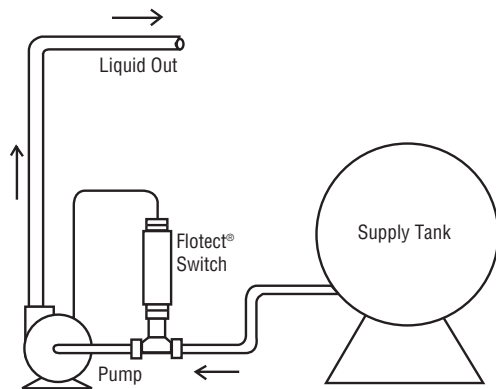

W.E. Anderson® Flotect® switch stops pump when flow stops.

When the liquid in this supply tank is exhausted, the W.E. Anderson® V6 Flotect® switch senses the loss of flow and stops the pump motor, preventing pump cavitation and saving energy.

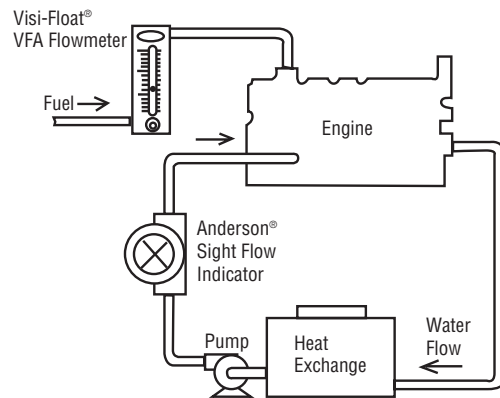

Fuel and cooling flow to large engines and compressors monitored by Dwyer flowmeter and W.E. Anderson® Sight Flow Indicators.

By indicating flow of cooling water to engines, compressors and other machinery, Sight Flow Indicators permit the operator to monitor the proper flow to protect the equipment. Engine fuel flow can be measured with a flowmeter. The Dwyer VFA flowmeter series is compatible with and can monitor the low flows encountered in fuel oil systems. W.E. Anderson® Flotect® switches (not shown), when inserted in the cooling water lines, can provide an alarm or system shutdown should the flow fall below a safe limit.

flow/level

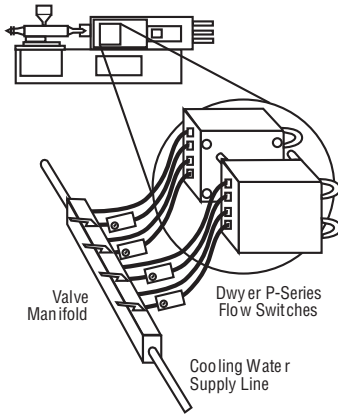

Dwyer P-Series Flow Switches prevent overheating of molds by ensuring water or coolant flow in injection molding machinery.

Plastic injection molding requires tight regulation of system temperatures to ensure perfect production. Overheating of molds is a common cause of production shutdowns and can result in faulty parts or even damaged molds. When installed into the mold cooling lines, Dwyer P-Series Flow Switches protect the expensive equipment by ensuring flow. If flow drops below the required rate or ceases entirely, the flow switches will enable system shutdown or alert an operator of the urgent situation. The switches can also ensure that water flow is turned on before the process begins by preventing start-up procedures until adequate flow is reached.

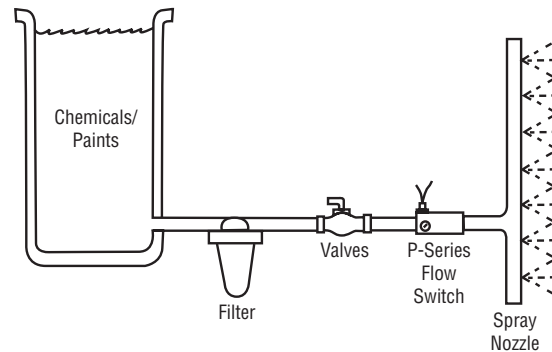

Dwyer P-Series flow switches protect pumps and ensure proper system operation in chemical and paint spraying processes.

Maintaining adequate flow rate is a critical factor in chemical and paint spraying systems. If fluid flow is inadequate, surfaces may not be covered evenly or efficiently. System pumps can also be damaged when flow falls off. A Dwyer P-Series Flow Switch can prevent these problems by indicating inadequate or fluctuating flow rates. By inserting the switch into the control circuit, system operation will cease before the equipment is allowed to function improperly. P-Series Flow Switches are ideal for this type of application because of their in-line design, high pressure limits, and easy installation and maintenance.

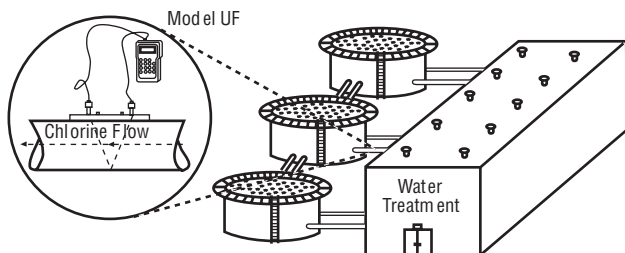

Water treatment facilities measure the flow rate of chlorine non-invasively with ultrasonic flowmeters.

Flow measurement of chlorine is a critical process in water treatment facilities. Using in-line flowmeters can prove to be very difficult due to the corrosive nature of the liquid. A portable Dwyer UF Ultrasonic Flowmeter can simply be strapped onto the outside of a pipe to accurately measure the flow rate of chlorine without ever coming into contact with the substance. Since Dwyer's ultrasonic flowmeters are easily installed and removed in seconds, they can be used to measure flow at different points in the process or even on completely different pipe sizes, eliminating the need for cumbersome fittings and threaded connections.

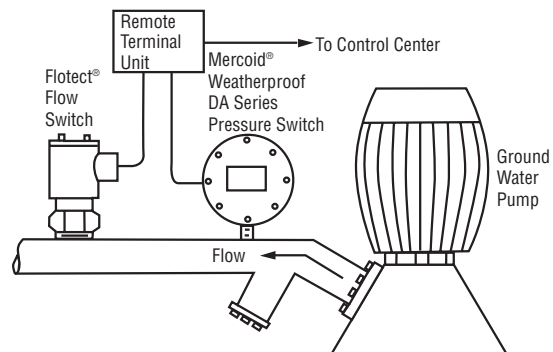

Flow and pressure switches protect large municipal water system pumps from damage.

Municipal water systems supplied by deep wells located at many locations throughout the system require reliable alarms at each pump in case of low suction or high discharge pressure conditions. Many systems also employ a Flotect® flow switch for added low suction alarm evidenced by low or no water flow. Both switches signal alarms to a remote terminal unit at the pumping location which, in turn, relays the alarm conditions and location to the central water system control station. The integral weatherproof construction of the Flotect® switch and optional weatherproof DA switch housing allow these controls to be located at outdoor pumping stations.

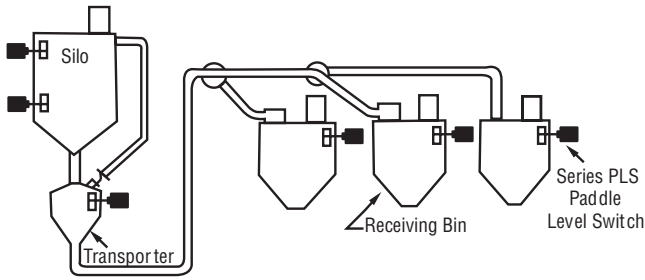

Proximity® Series PLS is used to indicate level status in pneumatic conveying systems.

Pneumatic conveying systems use air to transport powder and dry bulk solids through conveying lines. The air is pressurized by positive pressure or vacuum to move the product through the lines into and out of silos, transporters, and receivers. Typical applications have high and low level indication in the storage bins to control the flow of product in or out. The PLS is perfect for level use in these storage bins. It has a rotating paddle that is inserted into the bin. As the product level builds up in the bin it stops the paddle from rotating and triggers the level output. The PLS is great for this application as it not affected by pressure changes in the bin.

Mercoid® pump controller with level transmitter control pumps in wastewater lift stations.

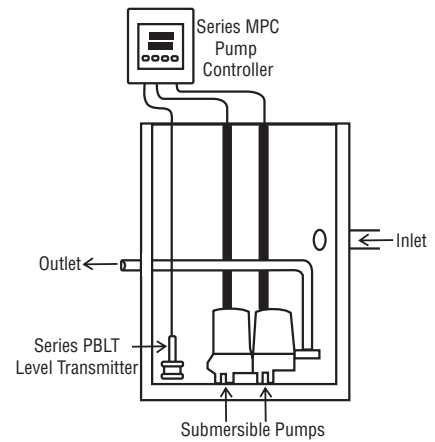

Lift stations are used to transmit wastewater to the treatment facility. Wastewater is transmitted by gravity feed so it has to be continually elevated to provide height to generate the flow. Lift stations are pits located at points in the wastewater system to collect the wastewater that usually have two submersible pumps. Wastewater in the lift station is pumped out to a higher level from where it can flow on to the next lift station or to the treatment facility. The Mercoid® Series MPC pump controller is used with the Series PBLT level transmitter to control the level in the lift station. The PBLT is a level transmitter that is submersed in the tank and sends a linear output of the height of wastewater above it. The MPC takes the height input and controls the pumps according to how it has been programmed. For a lift station, the primary pump comes on when the tank hits a high level and turns off when the level decreases to the set low level. The second pump is used if the first pump cannot drain the station and comes on at a set higher level above pump 1. High and low level alarms, submersible pump seal failure indication, pump over temperature protection, and pump alteration all are built into the MPC.

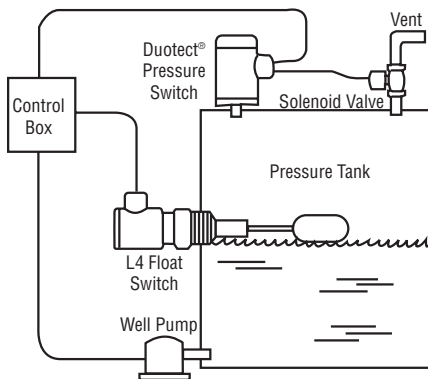

Switches control water level and tank pressure.

A hydro-pneumatic tank with a deep well pump maintains desired pressure in a water system. The pump, however, delivers entrained air along with make-up water, requiring periodic tank venting to prevent excess pressure buildup. As both water level and tank pressure must be maintained, one side of the W.E. Anderson® Duotect® pressure switch is interlocked with the W.E. Anderson® L4 float switch via the control box. When tank pressure falls below the preset system pressure due to water draw-down, the Duotect® switch starts the pump and transfers control to the float switch. When the preset water level is reached, the float switch turns the pump off. If entrained air has increased the pressure beyond the limit set in the other side of the Duotect® pressure switch, after a time delay covering several normal cycles, then the switch will open the solenoid valve and vent the tank down to proper pressure.

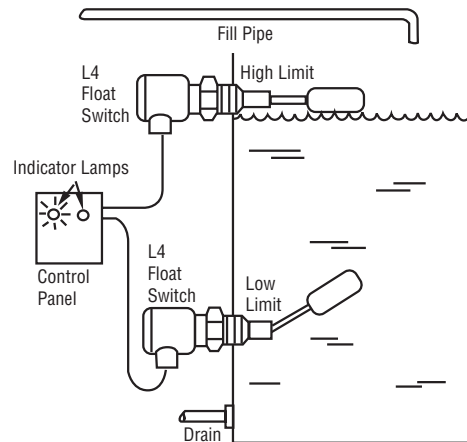

Reliable float switches monitor and control liquid level.

The W.E. Anderson® L4 float switch provides a simple, reliable means for monitoring and controlling the level of a liquid in a large tank. In this holding tank application, the lower L4 indicates to the operator that a tank fill cycle is required; the L4 can also control the necessary valve or pump to provide an automatic fill cycle. When the level of the liquid reaches the upper L4, the switch activates another indicator lamp or terminates the automatic fill cycle. The L4 float switch in optional stainless steel is recommended for level control of corrosive liquids, while the lower cost standard brass L4 serves well in most water and oil applications.

level

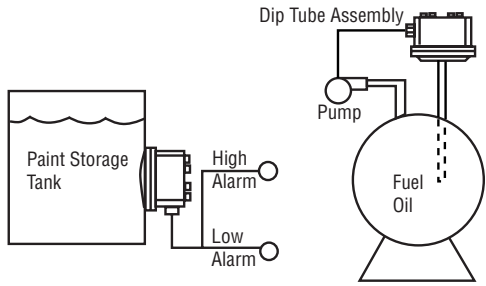

Fuel oil and paint liquid level switch applications require the Proximity® Sliquid™ pressure sensitive, magnetic diaphragm switches with one, two, or three precision switches.

A 3-switch Proximity® Sliquid™ model in the fuel oil application above turns a fuel pump on at low level (12"), turns the pump off at high level (48"), and activates the emergency shutoff at 51". In the paint storage application shown, a 2-switch Sliquid™ model operates a low level alarm (6" above the control) in an automated paint system. The high level switch activates a high level alarm when the paint level is 5' above the control. This unit can be applied for point levels up to 200 in. w.c. In the fuel oil application shown, a dip tube provides non-contact liquid level control. A flange-mounted contact method is illustrated in the paint application. Field adjustment is simple with high and low level springs that are adjusted using a screwdriver. Flexibility in models offered makes the Proximity® liquid level switch applicable for many requirements that vary from system to system.

Proximity® explosion-proof Ultra-Mag™ level switches provide powder and bulk solids level monitoring with suspended ("S") or flange ("F") mounted models.

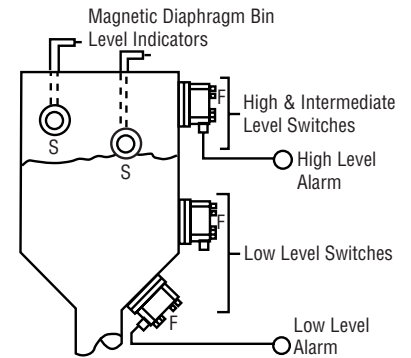

A magnetic coupling completely seals the switch(es) in the housing from the product and environment, ensuring high reliability and enhanced safety. Alarm capability is depicted above. Side mounted flange models are applicable for all bin levels. Top-of-the-bin suspension-mounted models for high and intermediate point level provide improved sensitivity (in materials with bulk densities as low as 5 pounds per cubic foot), and enhanced vertical adjustment capability compared to flange-mounted models. Elastomeric diaphragms are typically used in products such as fly ash, plastics, grain, powders, foundry sand, cement, aggregate, coal, metal chips, and glass. For pneumatic (pressure) applications the porous filter fabric diaphragms eliminate venting requirements due to an inherent ability to breathe. Many different diaphragm materials are available to fill the wide variety of needs in the industrial market.

Chemical waste and petroleum recycling are applications for the Proximity® S-D™ model, pressure sensitive magnetic diaphragm liquid level switches.

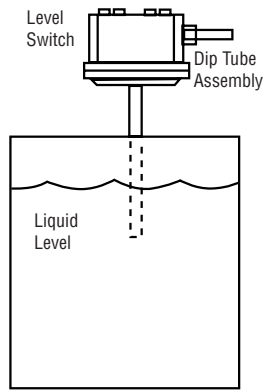

The magnetic coupling provides complete protection against environmental damage to the precision switch(es) in the housing. Protection is further enhanced in the convenient top-mounted dip tube application depicted, in which product does not touch the diaphragm. One or two switches in the housing are used to indicate point level of the liquid, or mixture, as it rises in the dip tube. Rising level causes static pressure in the dip tube to increase, depressing the diaphragm and causing repelling magnets on the diaphragm and switch arm(s) to actuate the switch(es) in the sealed housing. Falling level causes decreased static pressure in the dip tube and decreased repelling magnetic force(s). This allows spring force to overcome the magnetic force and return both the diaphragm and switch arm(s) to original positions. The S-D™ model is applicable for point levels up to 48 in. w.c. Thumbscrews in the housing allow simple adjustment of set points in the field. Both high and low levels can be monitored with the Proximity® S-D™ model. A variety of diaphragm materials make this a flexible product applicable in many industries.

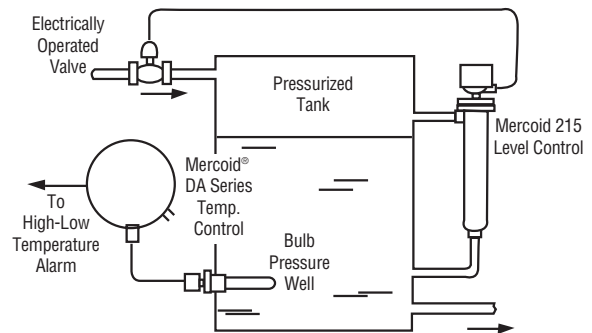

Mercoïd® level and temperature controls find wide application in high pressure and temperature processes.

In the example above, a pressurized holding tank in the process system is replenished with the process media by a supply line and electrically operated valve. The valve is controlled by a Mercoïd® 215 level control which can operate at system pressure to 300 psi at 500°F and features an adjustable level change from 1-1/2" to 24". The temperature of the media in the holding tank is monitored by a Mercoïd® DA Series bulb and capillary temperature control which has independent, externally adjustable high and low setpoints. The temperature control can actuate an alarm should the media temperature exceed the desired limits. A well in the side of the tank protects the bulb from the system pressure as well as allowing removal of the bulb and control without disrupting the process.

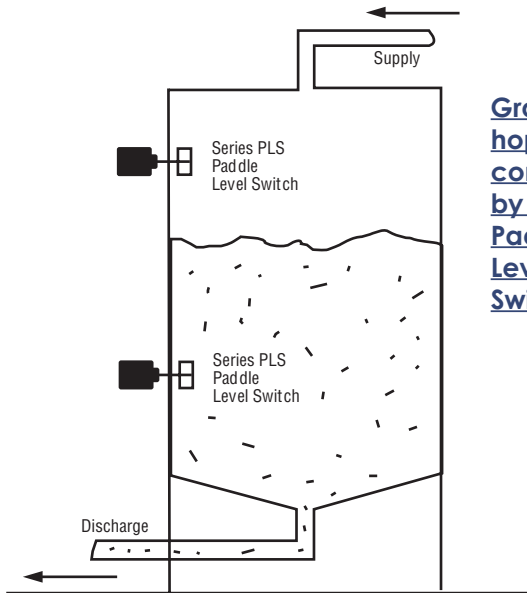

Grain hopper level controlled by Series PLS Paddle Level Switch.

The supply of grain pneumatically conveyed to this dispensing hopper is controlled by two Proximity® Series PLS paddle level switches. When the grain level falls to the low limit switch, the supply is turned on until the hopper fills to the level of the high limit switch which turns off the supply. Since grain dust is explosive, the explosion-proof Series PLS provides the required safety protection. The PLS is a paddle level switch and is not affected by the varying pressure in the hopper due to the cycling of the pneumatic conveying system.

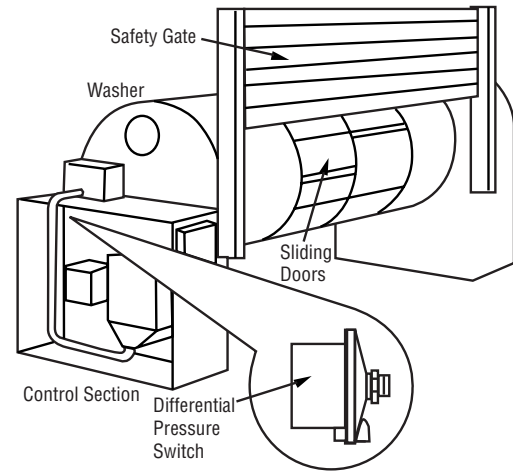

Differential pressure switch controls washer water level.

This large commercial automatic washing machine requires control of the wash and rinse water levels independent of the timed flow of inlet water which can vary with pressure. A Dwyer differential pressure switch is specified to sense the pressure developed by the head of water required for proper washer operation. The switch activates the appropriate valves to achieve the exact water level required each time. Sensing lines must be arranged to trap air on the fill cycle and drain completely with each completed cycle of the machine, or else they must be purged with instrument air.

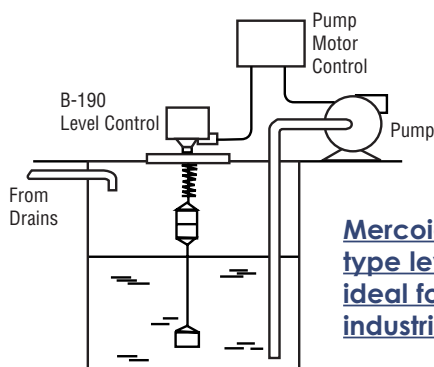

Mercoid® displacer type level control is ideal for controlling industrial sump pumps.

Industrial sumps and other underground tanks are ideal applications for top-mounted Mercoid® displacer type level controls. Easily installed, these controls use porcelain displacers that do not float on the surface of liquids, but are suspended on a coil spring and cable. As the liquid in the tank reaches the level of the upper displacers, their weight decreases by an amount equal to the liquid displaced, allowing the spring to move the cable upward, actuating the switch and the pump is turned on. As the liquid level falls below the upper displacers they move only a small amount, staying within the switch deadband until the liquid level falls to the center of the bottom displacer. At this point the switch is deactivated stopping the pump. The pump will remain deactivated until the water level rises to the upper displacers, repeating the cycle. The displacers are not affected by turbulence, pressure or chemicals and are excellent for tanks with viscous or dirty liquids. The level differential is easily adjusted by repositioning of the displacers on the 316SS cable.

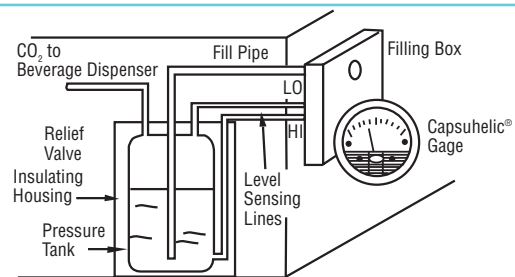

Fast-food restaurant liquid CO₂ tank uses gage as level indicator.

Many fast-food restaurants utilize liquid carbon dioxide as the source for pressurized CO₂ gas for dispensing soft drinks. Liquid CO₂ requires less storage space and avoids moving heavy compressed gas tanks in and out of the building. The storage tank also requires less frequent servicing which can be done from outside the building without interrupting operations. A Capsuhelic® differential pressure gage with its 500 psi rated operating pressure can safely handle the vapor pressure in the tank and indicate the level of the tank contents by monitoring the difference in pressure between the top and bottom of the insulated tank. The gage can be calibrated in empty-full increments, inches or gallons as desired. The high pressure (tank bottom) sensing line is run along the warm surface of the outer insulating housing to insure the liquid CO₂ is vaporized in the sensing line, keeping the cryogenic liquid from reaching the gage. Not all the piping and the system does include an over-pressure relief valve for safety reasons.

level

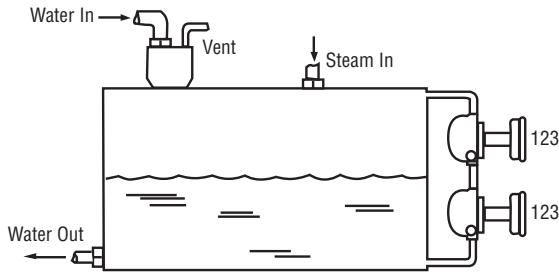

Mercoid® model 123 level controls provide high and low alarm on large de-aerator tank.

Liquid level in the external piping equals level in the tank. When level rises to high limit, float in upper model 123 is lifted, actuating switch to sound high level alarm. When level drops to low limit, lower model 123 sounds low level alarm.

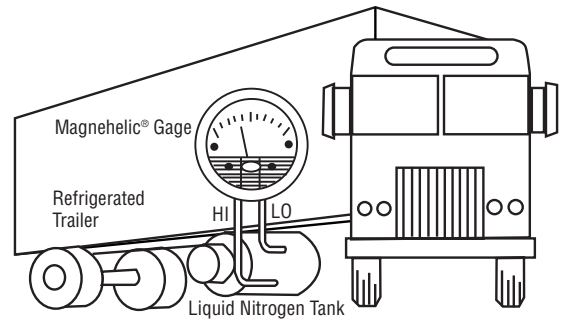

Differential pressure gage measures level of liquid nitrogen in tank.

Liquid nitrogen forms the basis for a simple, reliable and effective in-transit refrigeration system. When sprayed under its own gas pressure from the tank into the cargo space, the nitrogen changes from a liquid to a gas and absorbs heat. Depending on the tank vapor pressure, a Magnehelic® differential pressure gage with a medium or high pressure option or a Dwyer Capsuhelic® gage measures the level of liquid nitrogen in the closed tank. The high pressure tap samples hydrostatic pressure of the fluid at the tank bottom and the low pressure tap samples the gas pressure at the top of the tank. Normally, the small amount of liquid nitrogen entering the sensing line will be vaporized by ambient heat, thus purging the sensing line. The differential pressure is a function of the liquid nitrogen level. The gage can be calibrated for a given tank size in either percent of tank capacity or in pounds of liquid nitrogen. The Magnehelic® gage has proved its toughness by operating reliably in this over-the-road application for periods exceeding ten years.

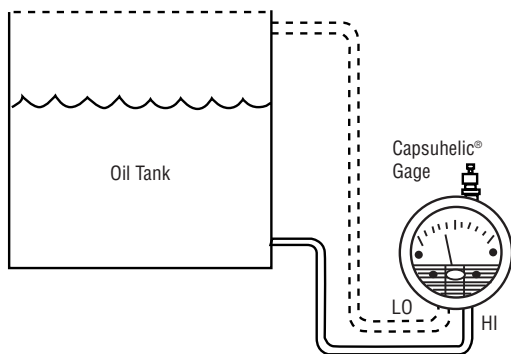

Dwyer gage indicates liquid level directly.

When used with a compatible liquid, a Dwyer Capsuhelic® differential pressure gage serves as a simple liquid level indicator. With the high pressure port connected to a tap at the bottom of the tank and the low pressure port vented to the atmosphere, the oil level can be read as a function of the head with direct calibration in feet or inches, taking into account the specific gravity of the liquid. If the tank is closed, as indicated by the dotted lines, the differential pressure produced by the head (and measured by having the low pressure port connected to a tap at the top of the tank) will yield the same results regardless of total tank pressure. As the gage will indicate head from its location to the level in the tank, the gage must be mounted at the same elevation as the bottom of the tank or some datum line. A minor amount of elevation correction can be made with the zero adjust screw. A brass housing is available for water level applications.

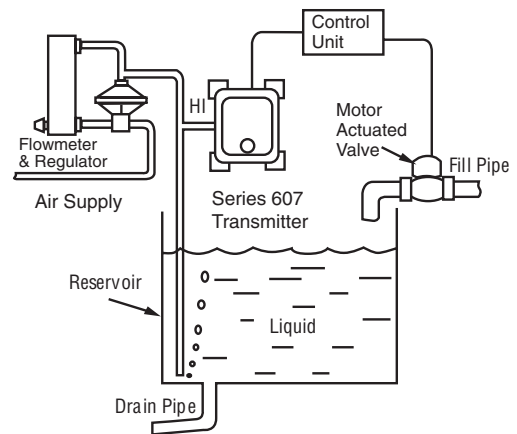

Transducer maintains constant liquid level in reservoir by controlling motor-actuated fill valve.

The liquid in this reservoir is maintained at a constant level by means of the motor actuated valve controlled by the pressure signal from a Dwyer Series 607 differential pressure transducer. The air pressure required to purge the dip tube of liquid is equal to the reservoir depth expressed in inches of water after taking into account the specific gravity of the liquid. Any change in reservoir level results in a proportional change in output current from the transducer which, when fed back through the control circuit, adjusts the valve to either increase or decrease the fill pipe flow to maintain the desired level.

level/temperature

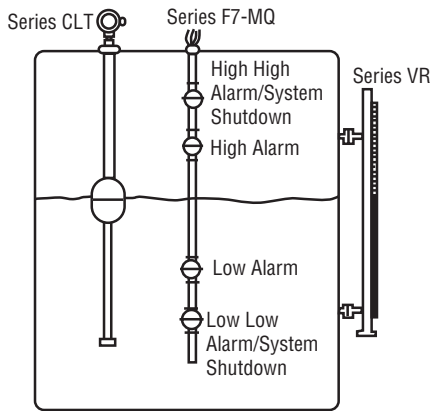

Custom level sensing devices are built to meet each customer's specific requirements, providing visual indication, continuous measurement, and point level control.

To meet various tank level measuring needs, Dwyer offers custom-configured products built to customer specifications that provide visual indication, continuous level measurement, and multiple point level measurement. Series VR or MVR View-Rite Level Indicators are a safe way to keep the process isolated while providing true visible indication. Unlike sight glasses, which can crack or break, View-Rite Indicators contain liquids entirely within their stainless steel enclosure. For continuous level measurement needs, the Series CLT uses reed switch technology to offer a more economical solution than expensive ultrasonic, submersible or RT transmitters. Lastly, the Series F7-MQ can be used in virtually any tank to indicate high and low alarms or to control pumps and valves.

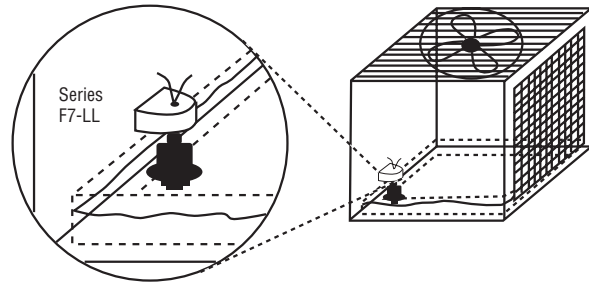

Low level float switch enables sensing in air conditioner drip pans and other shallow level applications.

Standard float switches require at least an inch of liquid to attain enough buoyancy to switch. This can be a problem in applications where low level sensing is required. The hat-shaped design of Dwyer's F7-LL provides necessary buoyancy for switching in only 5/8" of water. This is essential for air conditioner drip pans, low level sumps, and drains. The F7-LL is also ideal for low alarms, where running the process dry can result in catastrophic failure.

W.E. Anderson® Series OLS indicates level in heavy equipment radiator.

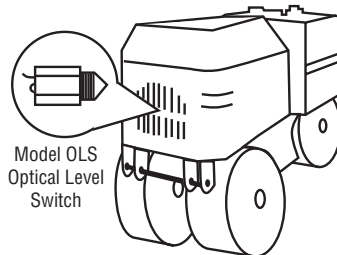

Many types of heavy industrial equipment use a liquid cooling system for the motor. A vibratory trench roller is a machine that compacts sub-bases for roads, parking lots, etc., and is an example of the type of equipment that would utilize this system. This machine incorporates a radiator cooling system. In the system, cooling liquid circulates through the engine preventing it from over heating. As the engine is cooled the cooling fluid heats up. The fluid returns to the radiator to cool down before being circulated through again. If there is not enough cooling fluid in the system the engine will not be cooled enough and damage will occur. A W. E. Anderson® Series OLS optical level switch is installed as a low level alarm. The level alarm is signaled by the OLS before the cooling fluid gets to a critical low level, warning the operator of the problem. The OLS uses an optical detection system superior for this application as float controls may trip from machine vibration. Also the compact insertion length is ideal for a small radiator.

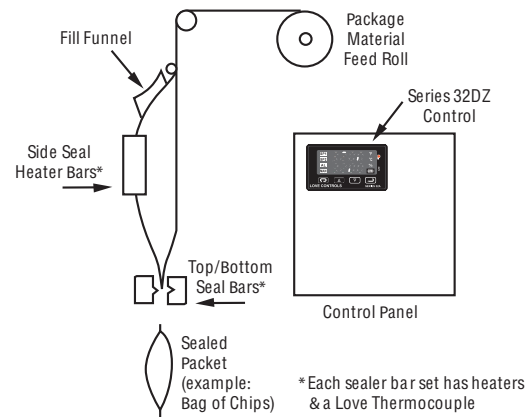

Form, fill and seal machine control simplified with dual zone control.

Form, fill and seal machines traditionally have used separate controls to handle the temperature control requirement for the side and top/bottom seal bars. The Love Controls 32DZ with Love 5000 Series thermocouples allows for a single small format (1/32 DIN) control to handle both zones, simplifying wiring and reducing panel costs.

The 32DZ can switch small resistive loads directly or, when used with the Love 2981 Series solid state relays (not shown), can switch larger loads.

temperature

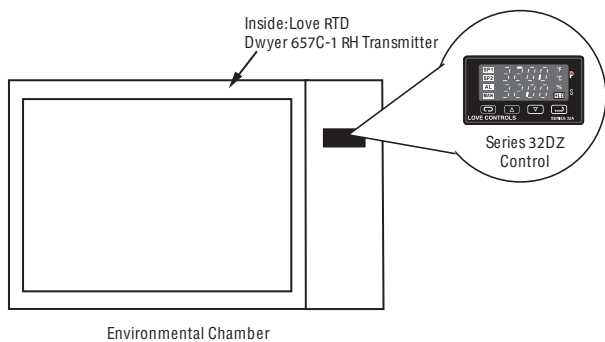

Environmental chamber control simplified with dial zone control.

Environmental chambers have traditionally used separate controls to handle the temperature and relative humidity control tasks. The Love Controls 32DZ dual zone control with Love 5000 Series RTD and Dwyer Series 657 Humidity transmitter controls both parameters in a single small format (1/32 DIN) control to handle both zones, simplifying wiring and reducing panel costs.

The 32DZ can switch small resistive loads directly or, when used with Love 2981 Series solid state relays (not shown), can switch larger loads.

For inductive loads (solenoids, motor starters, etc.) use the internal relays of the 32DZ to drive external contactors such as the Love 2481 Series.

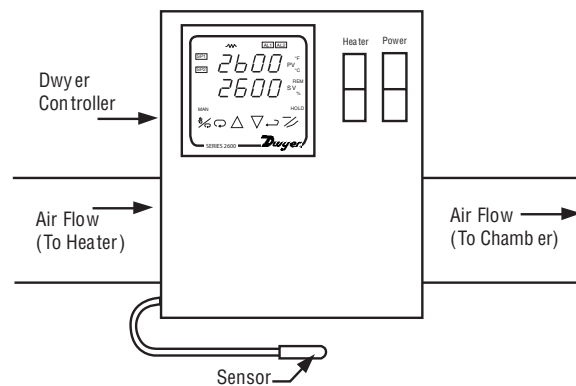

Dwyer controllers used within heater controllers.

In bioscience laboratories, the preferred methods of temperature control for experiments are heated water baths. There are experiments where water cannot be used, so the next feasible option is to send temperature controlled air to the experiment site. In order to use temperature controlled air, an air heater is needed. Within this product, a Dwyer temperature controller is used for accurate and responsive temperature control. The Dwyer controller can adapt to a different environment through different operating modes such as SELF-TUNE® or manual PID adjustments, or preset PID responses.

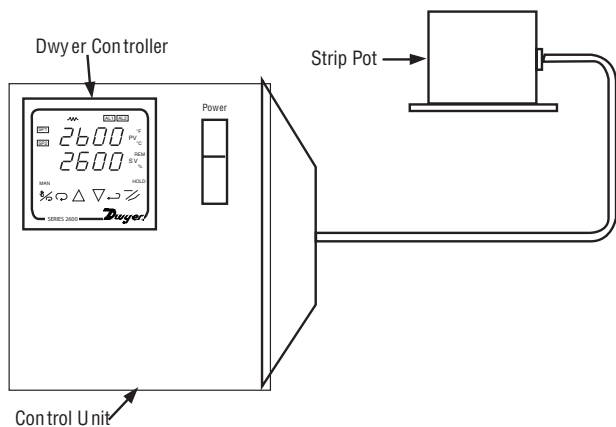

Dwyer controllers involved in insulation removal.

For most wires, removing the insulation is easy, but for magnetic and enamel wires, removing the insulation is very difficult. One way to easily remove the insulation of the magnetic or enamel wire is to dip them in a solution of molten fused salts. The salts are heated to a temperature high enough to melt the salts into a liquid, but not deteriorate them. This process uses a Dwyer feedback temperature controller. The Dwyer controller allows the operator to input a desired temperature and maintain that temperature accurately. The Dwyer controller will also retain the input temperature after the power is disconnected.

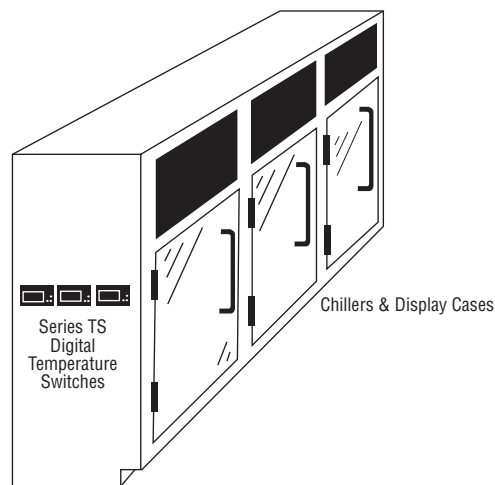

Series TS Digital Temperature Switches regulate temperature in chillers and display cases.

When storing food or other perishables in chillers or display cases, temperature must be carefully regulated to ensure the products remain fresh. If the storage area rises above the critical preservation temperature, products can have their shelf life dramatically shortened or be spoiled altogether. A Dwyer Series TS Digital Temperature Switch will prevent these scenarios by monitoring temperature and activating refrigeration and defrost cycles to ensure the storage temperature stays within safe limits.

temperature

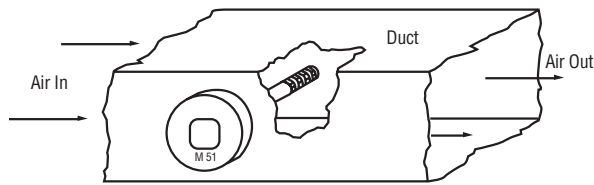

Mercoid® Model M-51R duct temperature switch provides high temperature cut-off on textile drying unit.

Hot air from a dryer flows past the Mercoid® Model M-51 duct temperature switch. If the temperature reaches a high set point, the bi-metal element rotates, actuating the switch to shut down the dryer. The unit will not re-start until the Model M-51 manual reset is actuated. The Model M-51 is mounted in a special well to prevent fouling by textile particles.

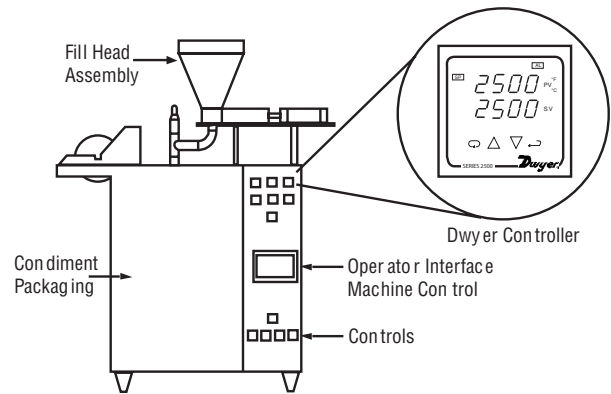

Dwyer controllers used in the packaging of condiments.

Packaging of condiments require the sealing bars to be heated to a temperature hot enough to seal the packages, but not destroy the packaging material. The heat on the sealing bars needs to be controlled to ensure the heat does not become excessive. Dwyer controllers are used in this process to accurately control the heat on the sealing bars. The sensors from the Dwyer controllers are placed on the sealing bars to ensure accurate temperature readings. Should the heat become excessive, an alarm light on the controller notifies the operator of the impending conditions.

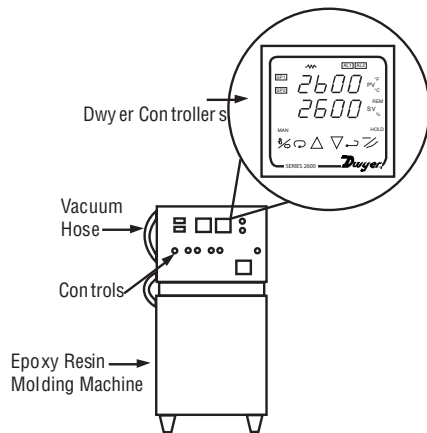

Resin transfer molding.

Accurate control of temperature and epoxy resin flow is important during resin transfer molding. For the epoxy resin to have an even and thorough flow, the resin must be at a temperature high enough to allow it to flow, yet not burn the resin. With the help of a Dwyer controller, the temperature of the resin is accurately controlled under different conditions through the different PID operating modes. Another Dwyer controller, with a flow transducer, is used in this process to control the flow of the epoxy resin. The Dwyer controller provides information on the temperature and flow rate to the computer through an RS485 serial communication option.

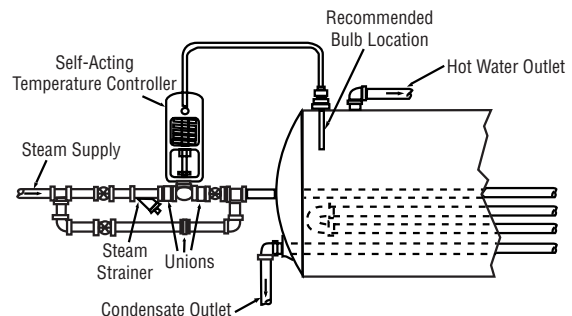

Regulating process temperature using W.E. Anderson® self-acting temperature control valve.

The self-acting temperature control valve features a self-contained valve, controller, and sealed thermal system in one compact package providing installation economy and long-term reliability. This package eliminates the temperature controller required with standard control valves. The dispensing application shown includes a 36R valve that opens when the temperature in the hot water tank decreases allowing the steam to heat the water and bring the temperature up to a required set point, at which point the valve will close. A valve that closes on temperature rise (direct acting) would be required for this application. The W.E. Anderson® Hi-Flow™ quick-opening, double seated valve enables fast response for improved process control in this application. If your application requires valve to open on temperature rise, then a reverse acting 36R is also offered.

temperature/valves

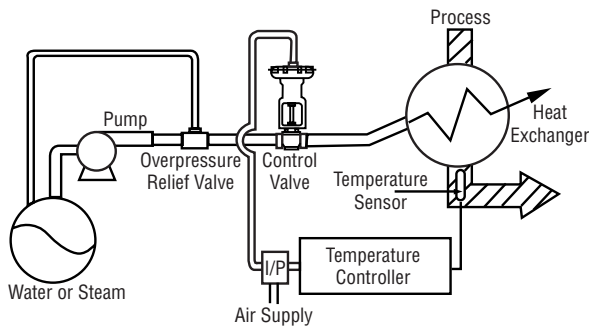

Process temperature control using pneumatic Hi-Flow™ control valves.

Pneumatic Hi-Flow™ control valves provide excellent control with high flow, wide rangeability and tight shutoff capabilities. The dispensing application shown uses a Lin-E-Aire® pneumatic actuator, operating off standard 3-15 psi control air signals, and a Hi-Flow™ linear control valve that apportions steam or water to a user process. The valve regulates cooling water or steam flow depending on the process requirement resident in the temperature controller program. This package can be provided with a Precisor® positioner and Proximity® position transmitter which provides an excellent process control application problem solution.

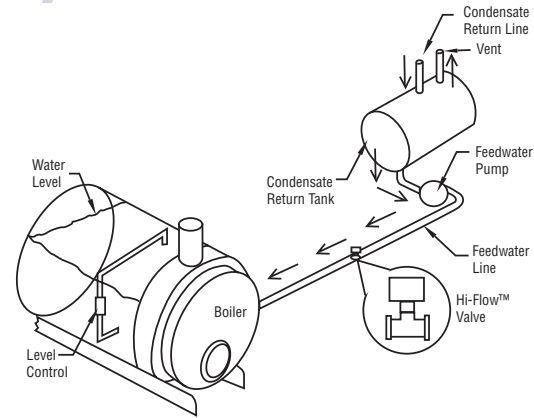

W.E. Anderson® Series Hi-Flow™ valves are used for flow control of water into industrial boilers.

Maintaining the proper water level in a boiler is critical to its proper operation. Too much water and water can get into the steam lines, while too little water and the boiler can over heat. Both conditions can lead to damage of the boiler or heating system. Feedwater going into the boiler needs to be controlled to maintain the proper boiler water level. The W. E. Anderson® Hi-Flow™ globe valve is used to control the flow of the feedwater to maintain that proper water level. The control valve is used with a proportioning electric actuator that is directly controlled by a level transmitter in the boiler. As the water level drops in the boiler the valve lets in more water and as water level increases the valve lets in less water. Thus proper water levels are always maintained keeping the boiler operating properly and efficiently.

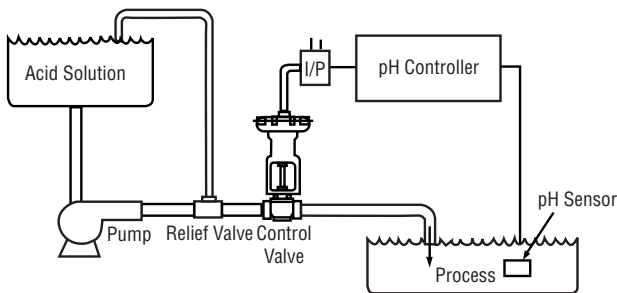

Regulating pH for food and dairy applications using linear or rotary pneumatic control valves.

Hi-Flow™ pneumatic control valve, available with bronze or 316 stainless steel body and 316 stainless steel trim, provides superior corrosion resistance and durability. A lined Plast-A-Vane® butterfly valve with pneumatic actuator could also be used to provide excellent corrosion resistant characteristics. Both types of valves yield superb flow characteristics and enhanced shut-off capabilities ensuring years of trouble-free, reliable operation. In the application shown, throttle action of the High-Flow™ linear globe valve, or the rotary movement of the Plast-A-Vane® quarter-turn butterfly valve, is used to regulate the flow of acid solution into a food/dairy process to accurately control the pH of the system.

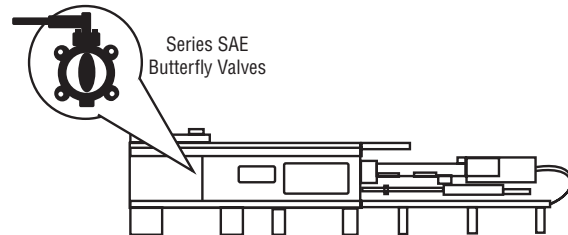

W.E. Anderson® Series SAE Butterfly Valves are utilized on hydraulic reservoirs on injection molding machines.

The SAE valve is used as a shut off valve on the hydraulic system on injection molding machines. Normally the valve is in the open position during operation. When the hydraulic pump needs servicing the valve is closed to isolate the hydraulic reservoir to prevent loss of hydraulic fluid. The SAE valve has connections conforming to SAE J518, which is a four screw split flange port. An o-ring seal is utilized in the connection design that reduces leaks associated with tapered thread and gasket type seals. The connection allows for the reduction of unneeded adapters and has a low profile reducing space requirements.

valves

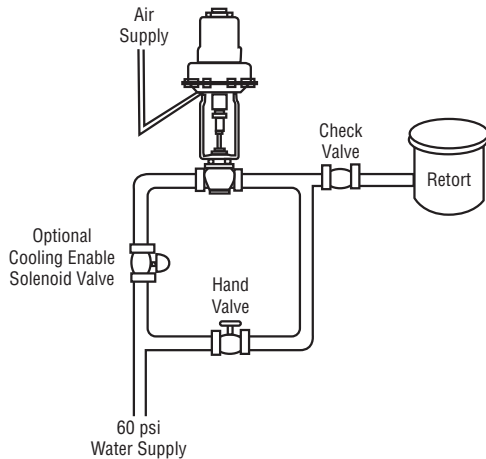

Quick response Hi-Flow™ valves control water flow in cooling process.

Dependable W.E. Anderson® Hi-Flow™ control valves with Lin-E-Aire® air-to-raise actuators combine to provide unsurpassed water flow management. This retort system employs the Hi-Flow™ valve because of its excellent control capabilities, which are necessary for this application. After the cooking process, the valve is opened slowly. Once the desired temperature has been reached, the supply is shut off and any additional cooling is done by use of the hand valve.

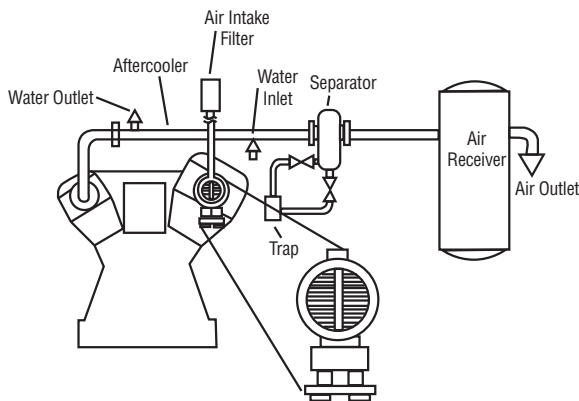

Compressor unloading using W.E. Anderson® Plast-A-Vane® butterfly valve.

When receiver pressure rises to a predetermined setting, the total closure valve closes automatically, blocking the air inlet and preventing air from entering the compressor. After all compressed air is evacuated from the cylinders and intercooler, the solenoid control valve on the high-pressure cylinder is opened to atmosphere allowing that minute amount of air remaining in the high-pressure cylinder to be exhausted. The compressor is now operating in a vacuum with minimal losses due only to mechanical friction in bearings and on sliding surfaces. Minimal horsepower is needed to overcome the mechanical losses.

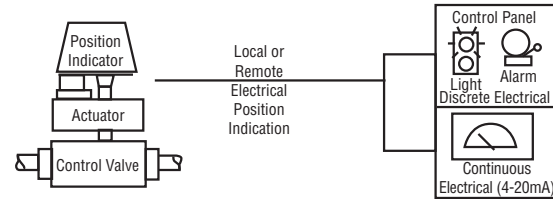

Proximity® Mark Series valve position indicator is perfect for valve position indication on offshore oil rigs.

Proximity® Mark Series position indicator is utilized in valve automation packages in harsh environments. The Mark Series mounts onto the top of rotary valve actuators and connects to the actuator shaft or attaches to the shaft of a linear valve for indicating valve position. Standard with the Mark Series is visual position indication with “OPEN”, “CLOSED”, and degree position status. The Mark Series is available with continuous position retransmission with a 4 to 20 mA output and up to six adjustable position indication switches for remote indication of valve status. Remote status transmitter is used for indication of exact valve position and switches provide discrete indication of valve open and closed status in the control room. The Mark Series is perfect for this application because of the 316 SS enclosure that withstands the sea spray environment, and the magnetic drive mechanism that completely seals the switch cavity from the environment.

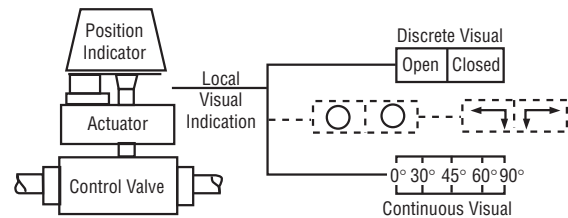

Visual valve position indication with Proximity® explosion-proof position indicators provides convenience and enhanced safety in valve monitoring.

For the convenience of the control valve user, a compact, adjustable stainless steel visual indicator is provided on all direct-drive Proximity® position indicating switches and transmitters. These industrial switches are commonly mounted on quarter-turn pneumatic actuators and valves. A magnetic design provides maximum safety by allowing complete sealing of the switch cavity. Over 2000 specific applications are covered with an extensive line of mounting kits built for individual valve and actuator brands and model numbers. As the valve and actuator is cycled, the input shaft of the position indicator rotates, causing a stainless steel cylinder to rotate inside a second stainless steel cylinder with windows. When the valve is open the word “OPEN” appears in the two windows located 180° apart. The compact and durable visual indicator displays discrete endpoints (OPEN or CLOSED) as well as scaled degrees (0-90). LED and flow path outputs are available options. Up to 3 conduit entrances allow utilization of this flexible indicator as a junction box for additional convenience as well as material and labor cost reduction to the user.

valves/miscellaneous

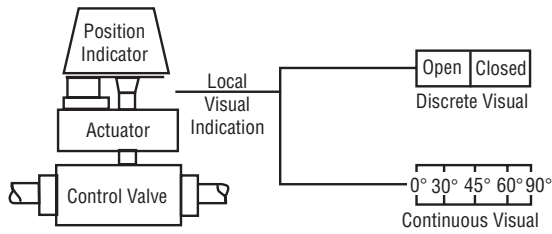

Proximity® Series QV indicates valve position locally and remotely.

Proximity® Series QV position indicator is utilized in valve automation package. Quarter turn valves such as ball and butterfly valves are often automated with pneumatic or electric actuators. The actuator connects to the shaft of the valve and rotates it. Usually the actuator has a shaft of its own that comes out of the top and rotates as the actuator rotates the valve. The QV mounts onto the top of the actuator and connects to this actuator shaft for indicating valve position. When the valve is open or closed, the corresponding word “OPEN” or “CLOSED” appears in four windows 90° apart. The visual indicator also includes degree position indication of 0 to 90°. The QV is compact yet the visual indicator is large and easy to view from a distance. Adjustable position indication switches are available to remotely indicate if the valve is fully opened or closed. The QV assures proper operation of the valve and indicates problems so they can quickly be addressed.

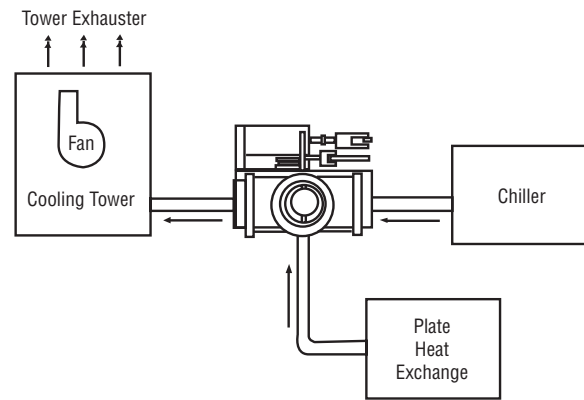

Water-side Economizer System includes Plast-A-Vane® 3-way butterfly valve for accurate control of flow.

To ensure efficient utilization of cold water in HVAC systems, W.E. Anderson® Plast-A-Vane® 3-way butterfly valves are called upon to modulate flow. This common “water-side economizer” allows water from the plate heat exchanger to be diverted directly to the cooling tower if the temperature is cool enough, instead of coming directly from the condenser on the chiller.

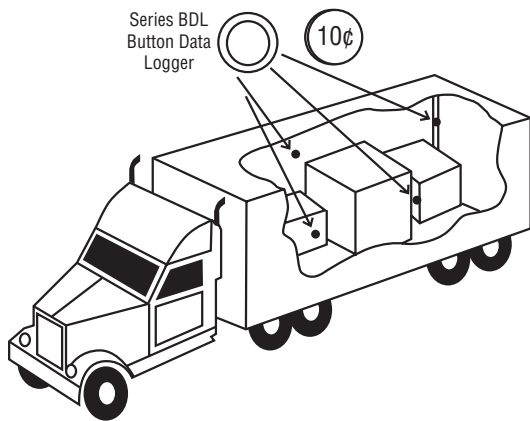

Button Datalogger monitors food and beverage temperature in refrigerated transport vehicles.

When transporting temperature-sensitive products such as meat, produce, beer and wine over long distances, it is necessary to verify that the storage compartment has not exceeded the critical preservation temperature at any time. Dwyer BDL Button Dataloggers offer a low cost way to measure and record storage temperatures throughout transport. By placing several “buttons” throughout the storage compartment and setting an appropriate measurement interval, transportation services can retrieve data at the completion of delivery to assure their customers of adequate preservation temperatures.

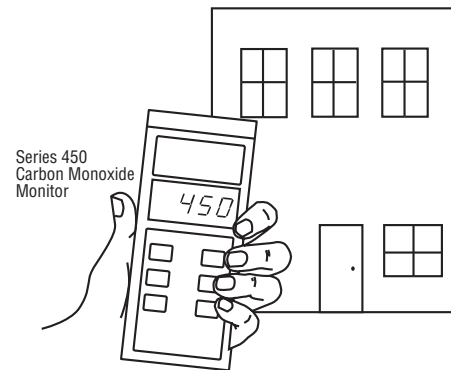

Quickly determine a building's carbon monoxide levels with Carbon Monoxide Monitor

The Dwyer Series 450 Carbon Monoxide Monitor is the ideal handheld instrument used by Building Inspectors and Building Maintenance Supervisors for inspecting indoor carbon monoxide (CO) levels. To determine if a building's indoor air meets safe allowable levels set by ASHRAE, an inspector can easily walk through a building with the 450 to see if the building meets code. With the 450's peak CO recording feature, the user can quickly determine if any part of the facility surpassed the safe allowable level. An audible and visual light respond when user programmed limits are exceeded. The 450 CO Monitor is also used by workers in tunnels, mines and sewers.

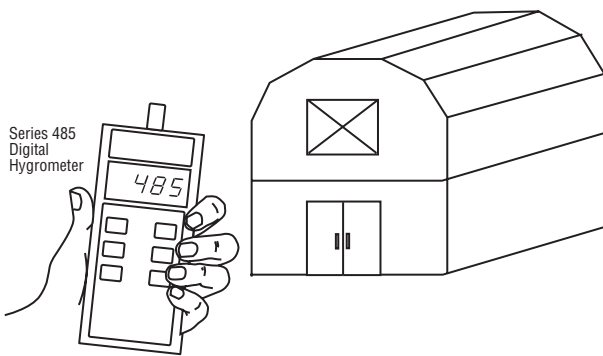

Quickly measure humidity and temperature levels in ambient air.

The Dwyer 485 Handheld Digital Hygrometer is a simple, portable device for quickly measuring humidity and temperature levels in ambient air. The dew point and wet-bulb temperature readings are derived from relative humidity and temperature measurements. The 485 is often used in agricultural applications where proper humidity and temperature levels are critical in plant or animal well being.

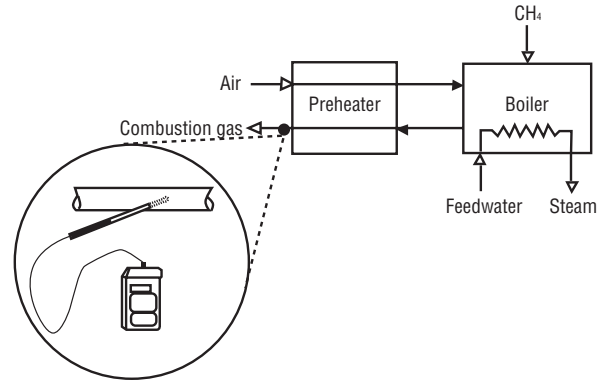

Combustion analyzer maximize boiler efficiency while monitoring harmful products of combustion.

There are several critical factors in attaining efficient combustion for boilers and other combustors. Monitoring the temperature of combustion and minimizing the amount of excess air in the system are undoubtedly essential steps. A Dwyer 1207-NO_x Flue Gas Analyzer can break down the products of combustion, giving an accurate volumetric composition of harmful NO_x compounds, O₂, CO₂, and CO. Additionally, the 1207-NO_x will monitor differential temperature, excess air and poison index. Results can be easily viewed on screen or uploaded to a PC via the user-friendly software.

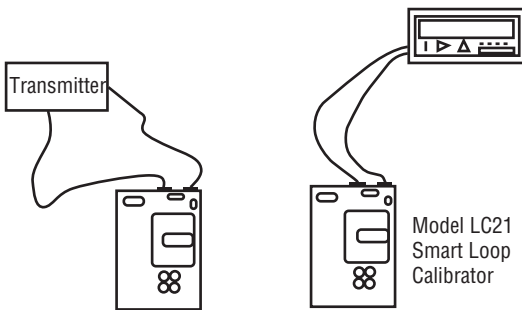

Perform field calibration of transmitters and control systems.

For testing transmitters and other process loop components, Dwyer's LC21 Smart Loop Calibrator is the ideal instrument. The LC21 can be used to simulate any two of the three basic components of an analog process loop, the transmitter, indicator, or power supply. To perform calibration tests on an indicator, panel meter, or PLC, the LC21 will simulate a transmitter by sourcing an analog output signal while providing the loop power supply. To perform calibration tests on a transmitter, the Smart Loop Calibrator will simulate the indicator while providing the power supply. The end result is a compact, portable, easy-to-use calibration tool for analog systems.

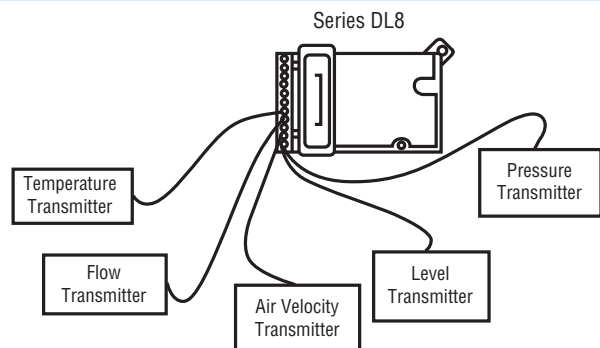

Dataloggers simplify performance assessment for multiple transmitters and other measurement devices.

Data acquisition is an essential tool for process monitoring and system evaluation. It is also an integral factor in troubleshooting and malfunction testing. Dwyer's DL8 Process Datalogger enables users to acquire data from up to seven transmitters or other instruments by accepting industry standard analog inputs. With easy-to-use software, plots of the instruments' performance can be conveniently uploaded and viewed graphically or numerically on a PC or laptop. Additionally, the DL8 can monitor data in real time for instant results or acquire data over a user-defined interval for long-term monitoring.

reference

reference

SPECIFIC GRAVITY OF LIQUID	
Liquid	Specific Gravity
Acetone	0.792
Alcohol, ethyl	0.791
Alcohol, methyl	0.810
Ammonia, saturated	0.655
Benzene	0.9
Brine (10% Na Cl)	1.08
Carbolic acid	0.950 to 0.965
Carbon disulfide	1.293
Carbon tetrachloride	1.595
Chloroform	1.489
Ether	0.736
Fuel Oils	
1	0.82 to 0.95
2	0.82 to 0.95
3	0.82 to 0.95
5A	0.82 to 0.95
5B	0.82 to 0.95
6	0.82 to 0.95
Gas oils	0.89
Gasolines	
a	0.74
b	0.72
c	0.68
Glycerine	1.260
Heptane-n	0.688
Hexane	0.664
Kerosene	0.820
Mercury	13.600
Methyl acetate	0.93
Methyl iodide	2.28
Milk	1.028 to 1.035
Naptha, petroleum ether	0.665
Naptha, wood	0.848 to 0.810
Oils	
Castor	0.969
Coconut	0.925
Cotton seed	0.926
Creosote	1.040 to 1.200
Linseed, boiled	0.924
Olive	0.918
Palm	0.924
Peanut	0.92
Sesame Seed	0.923
Soy Bean	0.924 to .928
Pentane	.623
Propylene glycol	1.038
SAE 30 Lube Oil	0.9
Sea Water	1.025
Sodium chloride	
5%	1.037
25%	1.196
	1.19
Sodium hydroxide (caustic soda)	
20%	1.22
30%	1.33
40%	1.43
Turpentine (spirits)	0.870
Water	1.000

ALTITUDE PRESSURE TABLE		
Mercury at 0°C (32°F)		
Altitude in feet	Inches of Mercury	In Millimeters of Mercury
-1,000	31.02	787.9
0	29.921	760.0
1,000	28.86	732.9
2,000	27.82	706.6
3,000	26.81	681.1
4,000	25.84	656.3
5,000	24.89	632.3
6,000	23.98	609.0
7,000	23.09	586.4
8,000	22.22	564.4
9,000	21.38	543.2
10,000	20.58	522.6
15,000	16.88	428.8
20,000	13.75	349.1
25,000	11.10	281.9
30,000	8.88	225.6
35,000	7.04	178.7
40,000	5.54	140.7
45,000	4.36	110.8
50,000	3.436	87.30

AREA OF CIRCLES IN FT ²			
Diam. in Inches	AREA Square Feet	Diam. in Inches	AREA Square Feet
1	.0054	30	4.909
1½	.0123	31	5.241
2	.0218	32	5.585
2½	.0341	33	5.940
3	.0491	34	6.305
3½	.0668	35	6.611
4	.0873	36	7.069
4½	.1105	37	7.467
5	.1364	38	7.876
5½	.1650	39	8.296
6	.1964	40	8.727
6½	.2305	41	9.168
7	.2673	42	9.621
7½	.3068	43	10.08
8	.3491	44	10.56
8½	.3940	45	11.04
9	.4418	46	11.54
9½	.4923	47	12.05
10	.5454	48	12.57
11	.6600	49	13.10
12	.7854	50	13.64
13	.9218	51	14.19
14	1.069	52	14.75
15	1.227	53	15.32
16	1.396	54	15.90
17	1.576	56	17.10
18	1.767	58	18.35
19	1.969	60	19.63
20	2.182	62	20.97
21	2.405	64	22.34
22	2.640	66	23.76
23	2.885	68	25.22
24	3.142	70	26.73
25	3.409	72	28.27
26	3.687	74	29.87
27	3.976	76	31.50
28	4.276	78	33.18
29	4.587	80	34.91

SPECIFIC GRAVITIES OF GASES		
(BASED ON 68°F AND 14.7 LBS. ABS.)		
ACETYLENE	C ₂ H ₂	.897
AIR	1.000
AMMONIA	NH ₃	.587
ARGON	A	1.378
BUTANE-N	C ₄ H ₁₀	2.390
BUTANE-ISO	(CH ₃) ₂ CH CH ₃	1.990
CARBON DIOXIDE	CO ₂	1.517
CARBON MONOXIDE	CO	.966
CHLORINE	Cl ₂	2.452
ETHANE	C ₂ H ₆	1.035
HELIUM	He	.138
HYDROGEN	H ₂	.070
METHANE	CH ₄	.553
NATURAL GAS665
		(Approx. Avg.)
NITRIC OXIDE	NO	1.035
NITROGEN	N ₂	.966
NITROUS OXIDE	N ₂ O	1.518
OXYGEN	O ₂	1.103
PROPANE	C ₃ H ₈	1.550
SULPHUR DIOXIDE	SO ₂	2.209

VOLUME EQUIVALENTS	
1 CU. FT. =	1728 Cu. In. 7.481 Gal. (U.S.) 28.317 Liters
1 GAL. (U.S.) =	231 Cu. In. .1337 Cu. Ft. 3.785 Liters 3785 Cu. Cm.
1 LITER =	.0353 Cu. Ft. .2642 Gal. (U.S.) 1000 Cu. Cm.

FLOW EQUIVALENTS			
1 Cu. Ft./Hr.	1 Cu. Ft./Min.	1 CC/Min.	1 CC/Hr.
.0166 Cu. Ft./Min.	60 Cu. Ft./Hr.	60 CC/Hr.	.0167 CC/Min.
.4719 LPM	28.316 LPM	.000035 Cu. Ft./Min.	.0000005 Cu. Ft./Min.
28.316 LPH	1699 LPH	.0021 Cu. Ft./Hr.	.00003 Cu. Ft./Hr.
471.947 CC/Min.	28317 CC/Min.	.001 LPM	.000017 LPM
28317 CC/Hr.	1,699,011 CC/Hr.	.06 LPH	.001 LPH
.1247 Gal./Min.	7.481 Gal./Min.	.00026 Gal./Min.	.000004 Gal./Min.
7.481 Gal./Hr.	448.831 Gal./Hr.	.0159 Gal./Hr.	.00026 Gal./Hr.
1 LPM	1 LPH	1 Gal./Min.	1 Gal./Hr.
60 LPH	.0166 LPM	60 Gal./Hr.	.0167 Gal./Min.
.035 Cu. Ft./Min.	.00059 Cu. Ft./Min.	.1337 Cu. Ft./Min.	.002 Cu. Ft./Min.
2.1189 Cu. Ft./Hr.	.035 Cu. Ft./Hr.	8.021 Cu. Ft./Hr.	.1337 Cu. Ft./Hr.
1000 CC/Min.	16.667 CC/Min.	3.785 LPM	.063 LPM
60,002 CC/Hr.	1000 CC/Hr.	227.118 LPH	3.785 LPH
.264 Gal./Min.	.004 Gal./Min.	3,785.412 CC/Min.	63.069 CC/Min.
15.851 Gal./Hr.	.264 Gal./Hr.	227,125 CC/Hr.	3785 CC/Hr.

Pressure Conversion Chart

in/H ₂ O	P.S.I.	in/Hg	mm/H ₂ O	mm/Hg	kg/cm ²	bar	mbar	Pa	kPa
.1	.0036	.0073	2.534	.1863	.0002	.0002	.2482	24.82	.0248
.2	.0072	.0146	5.067	.3726	.0005	.0005	.4964	49.64	.0496
.4	.0144	.0293	10.13	.7452	.0010	.0010	.9928	99.28	.0993
.6	.0216	.0440	15.20	1.118	.0015	.0015	1.489	148.9	.1489
.8	.0288	.0588	20.34	1.496	.0020	.0020	1.992	199.2	.1992
1.0	.0361	.0735	25.41	1.868	.0025	.0025	2.489	248.9	.2489
2	.0722	.1470	50.81	3.736	.0051	.0051	4.978	497.8	.4978
3	.1083	.2205	76.22	5.604	.0076	.0076	7.467	746.7	.7476
4	.1444	.2940	101.62	7.472	.0102	.0099	9.956	995.6	.9956
5	.1804	.3673	127.0	9.335	.0127	.0124	12.44	1244	1.244
6	.2165	.4408	152.4	11.203	.0152	.0149	14.93	1493	1.493
7	.2526	.5143	177.8	13.072	.0178	.0174	17.42	1742	1.742
8	.2887	.5878	203.2	14.940	.0203	.0199	19.90	1990	1.990
9	.3248	.6613	228.6	16.808	.0228	.0224	22.39	2239	2.239
10	.3609	.7348	254.0	18.676	.0254	.0249	24.88	2488	2.488
11	.3970	.8083	279.4	20.544	.0279	.0274	27.37	2737	2.737
12	.4331	.8818	304.8	22.412	.0304	.0299	29.86	2986	2.986
13	.4692	.9553	330.2	24.280	.0330	.0324	32.35	3235	3.235
14	.5053	1.029	355.6	26.148	.0355	.0348	34.84	3484	3.484
15	.5414	1.102	381.0	28.016	.0381	.0373	37.33	3733	3.733
16	.5774	1.176	406.4	29.879	.0406	.0398	39.81	3981	3.981
17	.6136	1.249	431.8	31.752	.0431	.0423	42.31	4231	4.231
18	.6496	1.322	457.2	33.616	.0457	.0448	44.79	4479	4.479
19	.6857	1.396	482.6	35.484	.0482	.0473	47.28	4728	4.728
20	.7218	1.470	508.0	37.352	.0507	.0498	49.77	4977	4.977
21	.7579	1.543	533.4	39.22	.0533	.0523	52.26	5226	5.226
22	.7940	1.616	558.8	41.09	.0558	.0547	54.74	5474	5.474
23	.8301	1.690	584.2	42.96	.0584	.0572	57.23	5723	5.723
24	.8662	1.764	609.6	44.82	.0609	.0597	59.72	5972	5.972
25	.9023	1.837	635.0	46.69	.0634	.0622	62.21	6221	6.221
26	.9384	1.910	660.4	48.56	.0660	.0647	64.70	6470	6.470
27	.9745	1.984	685.8	50.43	.0685	.0672	67.19	6719	6.719
28	1.010	2.056	710.8	52.26	.0710	.0696	69.64	6964	6.964
29	1.047	2.129	736.8	54.18	.0736	.0722	72.19	7219	7.219
30	1.083	2.205	762.2	56.04	.0762	.0747	74.67	7467	7.467
31	1.119	2.278	787.5	57.91	.0787	.0772	77.15	7715	7.715
32	1.155	2.352	812.8	59.77	.0812	.0796	79.63	7963	7.963
33	1.191	2.425	838.2	61.63	.0837	.0821	82.12	8212	8.212
34	1.227	2.498	863.5	63.49	.0862	.0846	84.60	8460	8.460
35	1.263	2.571	888.9	65.36	.0888	.0871	87.08	8708	8.708
36	1.299	2.645	914.2	67.22	.0913	.0896	89.56	8956	8.956
37	1.335	2.718	939.5	69.08	.0938	.0920	92.04	9204	9.204
38	1.371	2.791	964.9	70.95	.0964	.0945	94.53	9453	9.453
39	1.408	2.876	990.9	72.86	.0990	.0971	97.08	9708	9.708
40	1.444	2.949	1016	74.72	.1015	.0996	99.56	9956	9.956
41	1.480	3.013	1042	76.59	.1040	.1020	102.04	102.04	10.204
42	1.516	3.086	1067	78.45	.1066	.1045	104.5	1045	10.45
43	1.552	3.160	1092	80.31	.1091	.1070	107.0	1070	10.70
44	1.588	3.233	1118	82.18	.1116	.1095	109.5	1095	10.95
45	1.624	3.306	1143	84.04	.1142	.1120	112.0	1120	11.20
46	1.660	3.378	1168	85.90	.1167	.1144	114.5	1145	11.44
47	1.696	3.453	1194	87.76	.1192	.1169	116.9	1169	11.69
48	1.732	3.526	1219	89.63	.1218	.1194	119.4	1194	11.94
49	1.768	3.600	1244	91.49	.1243	.1219	121.9	1219	12.19
50	1.804	3.673	1270	93.35	.1268	.1244	124.4	12438	12.44
51	1.841	3.748	1296	95.27	.1294	.1269	126.9	12693	12.69
52	1.877	3.822	1321	97.13	.1320	.1294	129.4	12941	12.94
53	1.913	3.895	1346	98.99	.1345	.1319	131.9	13190	13.19
54	1.949	3.968	1372	100.8	.1370	.1344	134.4	13438	13.44
55	1.985	4.041	1397	102.7	.1395	.1369	136.9	13686	13.69
56	2.021	4.115	1422	104.6	.1421	.1393	139.3	13934	13.93
57	2.057	4.188	1448	106.4	.1446	.1418	141.8	14182	14.18
58	2.093	4.261	1473	108.3	.1471	.1443	144.3	14431	14.43
59	2.129	4.335	1498	110.2	.1497	.1468	146.8	14679	14.68
60	2.165	4.408	1524	112.0	.1522	.1493	149.3	14927	14.93
61	2.202	4.483	1550	113.9	.1548	.1518	151.8	15182	15.18
62	2.238	4.556	1575	115.8	.1573	.1543	154.3	15430	15.43
63	2.274	4.630	1600	117.7	.1599	.1568	156.8	15679	15.68
64	2.310	4.703	1626	119.5	.1624	.1593	159.3	15927	15.93
65	2.346	4.776	1651	121.4	.1649	.1618	161.8	16175	16.18
66	2.382	4.850	1676	123.3	.1674	.1642	164.2	16423	16.42
67	2.418	4.923	1702	125.1	.1700	.1667	166.7	16672	16.67
68	2.454	4.996	1727	127.0	.1725	.1692	169.2	16920	16.92
69	2.490	5.070	1752	128.8	.1750	.1717	171.7	17168	17.17
70	2.526	5.143	1778	130.7	.1776	.1742	174.2	17416	17.42
71	2.562	5.216	1803	132.6	.1801	.1766	176.6	17664	17.66
72	2.598	5.290	1828	134.4	.1826	.1791	179.1	17912	17.91
73	2.635	5.365	1854	136.4	.1852	.1817	181.7	18168	18.17
74	2.671	5.438	1880	138.2	.1878	.1842	184.2	18416	18.42
75	2.707	5.511	1905	140.1	.1903	.1866	186.6	18664	18.66
76	2.743	5.585	1930	141.9	.1928	.1891	189.1	18912	18.91
77	2.779	5.658	1956	143.8	.1954	.1916	191.6	19160	19.16
78	2.815	5.731	1981	145.7	.1979	.1941	194.1	19409	19.41
79	2.851	5.805	2006	147.5	.2004	.1966	196.6	19657	19.66
80	2.887	5.878	2032	149.4	.2030	.1991	199.1	19905	19.90
81	2.923	5.951	2057	151.2	.2055	.2015	201.5	20153	20.15
82	2.959	6.024	2082	153.1	.2080	.2040	204.0	20402	20.40
83	2.996	6.100	2108	155.0	.2106	.2066	206.6	20657	20.66
84	3.032	6.173	2134	156.9	.2131	.2091	209.1	20905	20.90
85	3.068	6.246	2159	158.8	.2157	.2115	211.5	21153	21.15
86	3.104	6.320	2184	160.6	.2182	.2140	214.0	21401	21.40
87	3.140	6.393	2210	162.5	.2207	.2165	216.5	21650	21.65
88	3.176	6.466	2235	164.4	.2233	.2190	219.0	21898	21.90
89	3.212	6.540	2260	166.2	.2258	.2215	221.5	22146	22.15
90	3.248	6.613	2286	168.1	.2283	.2239	223.9	22394	22.39
91	3.284	6.686	2311	169.9	.2309	.2264	226.4	22642	22.64
92	3.320	6.760	2336	171.8	.2334	.2289	228.9	22890	22.89
93	3.356	6.833	2362	173.7	.2359	.2314	231.4	23139	23.14
94	3.392	6.906	2387	175.5	.2384	.2339	233.9	23387	23.39
95	3.429	6.981	2413	177.4	.2410	.2364	236.4	23642	23.64
96	3.465	7.055	2438	179.3	.2436	.2389	238.9	23890	23.89
97	3.501	7.128	2464	181.2	.2461	.2414	241.4	24138	24.14
98	3.537	7.201	2489	183.0	.2486	.2439	243.9	24387	24.39
99	3.573	7.275	2514	184.9	.2512	.2464	246.4	24635	24.64
100	3.609	7.348	2540	186.8	.2537	.2488	248.8	24883	24.88

P.S.I.	in/H ₂ O	in/Hg	mm/H ₂ O	mm/Hg	kg/cm ²	bar	mbar	Pa	kPa
1.0	27.71	2.036	703.1	51.75	.0703	.0689	68.95	6895	6.895
1.1	30.45	2.240	773.4	56.89	.0773	.0758	75.84	7584	7.584
1.2	33.22	2.443	843.7	62.06	.0844	.0827	82.74	8274	8.274
1.3	35.98	2.647	914.0	67.23	.0914	.0896	89.63	8963	8.963
1.4	38.75	2.850	984.3	72.40	.0984	.0965	96.52	9652	9.652
1.5	41.52	3.054	1055	77.57	.1055	.1034	103.4	10340	10.34
1.6	44.29	3.258	1125	82.74	.1125	.1103	110.3	11030	11.03
1.7	47.06	3.461	1195	87.92	.1195	.1172	117.2	11720	11.72
1.8	49.82	3.665	1266	93.09	.1266	.1241	124.1	12410	12.41
1.9	52.59	3.868	1336	98.26	.1336	.1310	131.0	13100	13.10
2.0	55.36	4.072	1406	103.4	.1406	.1379	137.9	13790	13.79
2.1	58.13	4.276	1476	108.6	.1476	.1448	144.8	14480	14.48
2.2	60.90	4.479	1547	113.8	.1547	.1517	151.7	15170	15.17
2.3	63.67	4.683	1617	118.9	.1617	.1586	158.6	15860	15.86
2.4	66.43	4.886	1687	124.1	.1687	.1655	165.5	16550	16.55
2.5	69.20	5.090	1758	129.3	.1758	.1724	172.4	17240	17.24
2.6	71.97	5.294	1828	134.5	.1828	.1793	179.3	17930</	



DWYER INSTRUMENTS, INC.

P.O. Box 373
Michigan City, IN 46361-9986

Return Service Requested

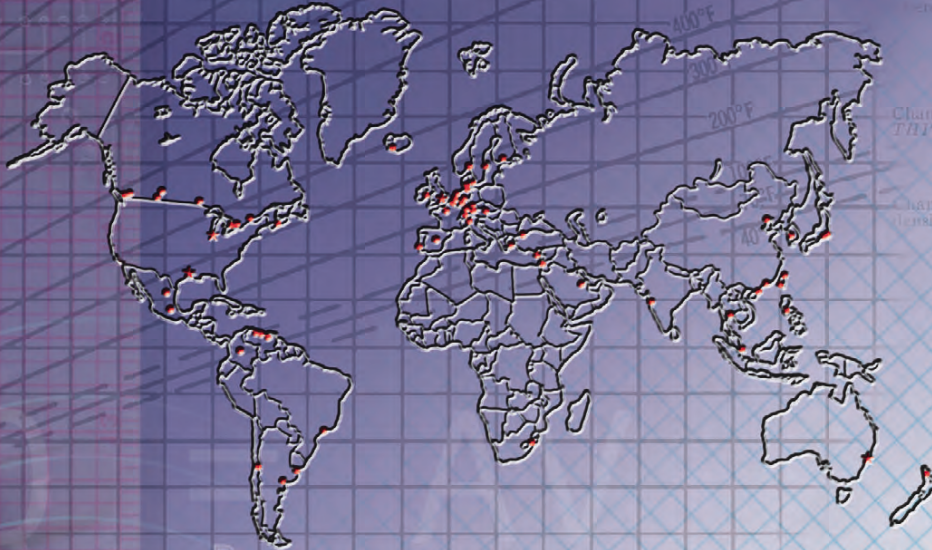

Dwyer Instruments, Incorporated, has presence in 45 countries. Please contact us for your nearest Dwyer representative.

Dwyer Instruments, Incorporated, hat Niederlassungen in 45 Ländern. Bitte setzen Sie sich wegen Ihres nächsten Kontaktmannes mit uns in Verbindung.

Dwyer Instruments, Incorporated, ha una presenza in 45 nazioni. Chiamateci per il nome del rappresentante più vicino.

Dwyer Instruments, Incorporated, a établi une présence dans 45 pays. Prière de nous contacter pour savoir le nom du représentant Dwyer le plus proche.

Relationships

number $dl = \frac{V_a}{C} = V_a \sqrt{\frac{\rho_1}{\rho_2}}$

- V_a = true airspeed
- C = sound velocity
- γ = specific heat ratio
- g = gravitational constant
- R = gas constant
- T = ambient temperature

Change in velocity with change in air density at constant temperature

$V_2 = V_1 \sqrt{\frac{\rho_1}{\rho_2}}$ (approximate)

Change in velocity with change in power at constant density

$V_2 = V_1 \sqrt{\frac{hp_2}{hp_1}}$ (approximate)

Corporate Headquarters

Dwyer Instruments, Inc.
102 Indiana Highway 212
P.O. Box 373
Michigan City, IN 46361 U.S.A.
Telephone: 219/879-8000
Fax: 219/872-9057

Houston Office:

Telephone: 281/446-1146
Fax: 281/446-0696

Australia



Dwyer Instruments, Pty. Ltd.
Unit 4, 11 Waverley Drive
Unanderra, NSW 2526 Australia
Telephone: 61 2 4272 2055
Fax: 61 2 4272 4055

United Kingdom



Dwyer Instruments Limited
Unit 16, The Wye Estate, London Road
High Wycombe, Bucks HP11 1LH-U.K.
Telephone: (+44) (0)1494 461707
Fax: (+44) (0)1494 465102