

WIRELESS HYDRONIC DIFFERENTIAL PRESSURE MANOMETER

Liquid and Gas Pressure Measurement, $\pm 2\%$ of Reading Accuracy

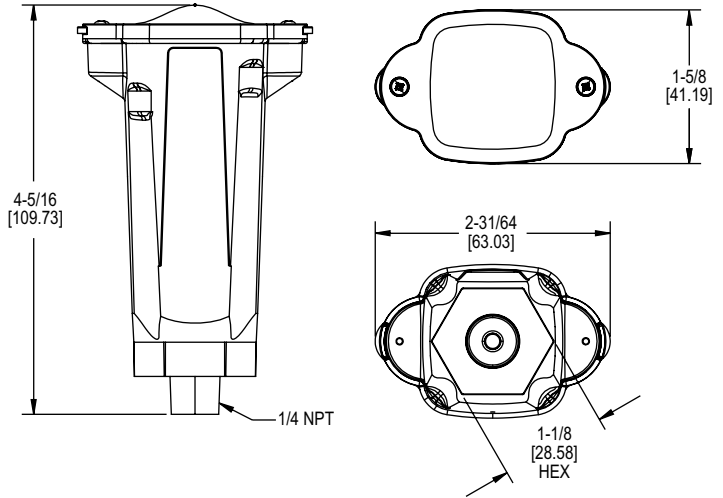

The **Series 490W Wireless Hydronic Differential Pressure Manometer** is the most accurate and easy to operate manometer on the market. By using wireless transducers and a mobile device, a single operator can monitor and balance a hydronic system in less time than traditional hydronic balancers. The Series 490W transducers connect wirelessly to a UHH6 or newer handheld device, or your own mobile device, to monitor differential pressure and flow on up to three different valves. Being wireless, there are no hoses to carry, snag on equipment or needing to be drained. The 490W utilizes Dwyer's hydronic application software that contains valve charts for numerous manufacturers, which converts differential pressure to flow directly on the screen.

BENEFITS/FEATURES

- Rugged weatherproof handheld housing withstands 1.0 meter drop test
- Wireless measurement of differential pressure, single pressure and air flow
- Bluetooth direct wireless communication provides range up to 65 ft (19.8 m)
- The ergonomic design is much lighter and easier to work with, providing greater maneuverability and quick install setup

APPLICATIONS

- Refrigerant pressure testing
- Hydronic valve balancing
- Measure pressure drop across pumps
- Measure pressure drop across chiller and coils for freeze protection

SPECIFICATIONS	
Wireless Distance:	Up to 65' (19.8 m).
Service:	Compatible gases and liquids.
Wetted Materials:	Transducer: 316L SS.
Accuracy:	2% of reading, ± 0.5 psi.
Compensated Temperature Range:	32 to 140°F (0 to 60°C).
Pressure Hysteresis:	$\pm 0.25\%$ FS.
Pressure Range:	0 to 200 psi (0 to 1379 kPa).
Maximum Pressure:	400 psi.
Engineering Units:	psi, ft w.c., in w.c., Pa, kPa, hPa, cm w.c., mm w.c.
Process Temperature Limits:	-4 to 185°F (-20 to 85°C).
Resolution:	0.0001 psi.
Process Connections:	Two 1/4" male NPT.
Power Requirements:	2x AAA batteries (each sensor), user replaceable.
Weight:	Kit: 5 lb (2268 g); Sensor: 0.25 lb (113 g).
Supported Devices:	UHH6 and newer, and smart devices with Bluetooth® v5.0 and Bluetooth® Low Energy (LE) wireless technology.
Supported Operating System:	Android® firmware version 8.0 and above.
Compliance:	CE, FCC.

MODEL CHART	
Model	Description
490W-6-HKIT	Full kit with (2) each 200 psi sensors
490W-6-HKIT-NIST	Full kit with (2) each 200 psi sensors with NIST certification
490W-6-INT-NIST	International version. Full kit with (2) each 200 psi sensors with NIST certification

ACCESSORIES	
Model	Description
A-HKIT-500	Pressure test plug adapter for the 490A-HKIT, 1/8" dia x 1-1/2" length (2 per kit)
A-HKIT-510	Pressure test plug adapter for the 490A-HKIT, 1/16" dia x 1-1/2" length (2 per kit)
A-HKIT-500XL	Pressure test plug adapter for the 490A-HKIT, 1/8" dia x 3" length (2 per kit)
A-490W-6	Replacement sensors, (2) each, 0-200 psi
A-490W-6-NIST	Replacement sensors, (2) each, 0-200 psi with NIST calibration
A-490W-CAPS	(2) each replacement caps for sensors
UHH7	Universal handheld test device with software

Manometers, Portable

USA: California Proposition 65
WARNING: This product can expose you to chemicals including Lead, which is known to the State of California to cause cancer and birth defects or other reproductive harm. For more information go to www.P65Warnings.ca.gov.

Android® is a registered trademark of Google, Inc.
 Bluetooth® is a registered trademark of Bluetooth SIG, Inc.