



November 06, 2024

Dwyer Instruments  
102 Indiana Highway 212  
Michigan City IN 46360

Our Reference: File SV31316 / Project 4791482734

Subject: UL Standard 2043, Fifth Edition, dated September 14, 2023.  
"Fire Test for Heat and Visible Smoke Release for Discrete Products and Their  
Accessories Installed in Air-Handling Spaces".

CAN/ULC - S142, First Edition, dated September 1st, 2016 - R2021  
Fire Test for Heat and Visible Smoke Release For Discrete Products.

Dear Jeff Meuli:

This Report summarizes the data developed on the samples you provided, which were subjected to the flame test described in UL Standard 2043, Fifth Edition, dated September 14, 2023 and CAN/ULC S142-R2021, First Edition, dated September 2016. Testing was conducted at UL LLC (UL) on October 15, 2024 at our Northbrook testing facility.

**GENERAL:**

It should be understood that these results apply only to the particular sample submitted for testing. The test results indicated in this Report are not intended to imply Listing, Classification or Recognition of any product or materials.

It is important to understand that authorities having jurisdiction may require that products such as covered by this report, intended for installation in a building plenum, be listed and labeled for such use in accordance with UL2043 and CAN/ULC-S142, based on current model building and electrical codes. Accordingly, you may wish to consider undergoing a Listing program with UL on your product(s) to address this possible need.

The Classification Marking or Listing Mark of UL on the product is the only method provided by UL to identify products that have been produced under its Classification or Listing and Follow-Up Service.

In no event shall UL be responsible to anyone for whatever use or nonuse is made of the information contained in this Report and in no event shall UL, its employees, or its agents incur any obligation or liability for damages, including, but not limited to, consequential damages, arising out of or in connection with the use, or inability to use, the information contained in this Report.

# TEST RECORD

## SAMPLES:

The product evaluated are described in Table 1. UL did not witness the production of the test sample, nor were we provided with information relative to the formulation or identification of component materials used in the manufacture of the test samples.

Table 1 - Sample Description

Sample Reference	Description
A	616KX - NPT Version with Makrolon Plastic Material

Test results are representative for the three models shown below.

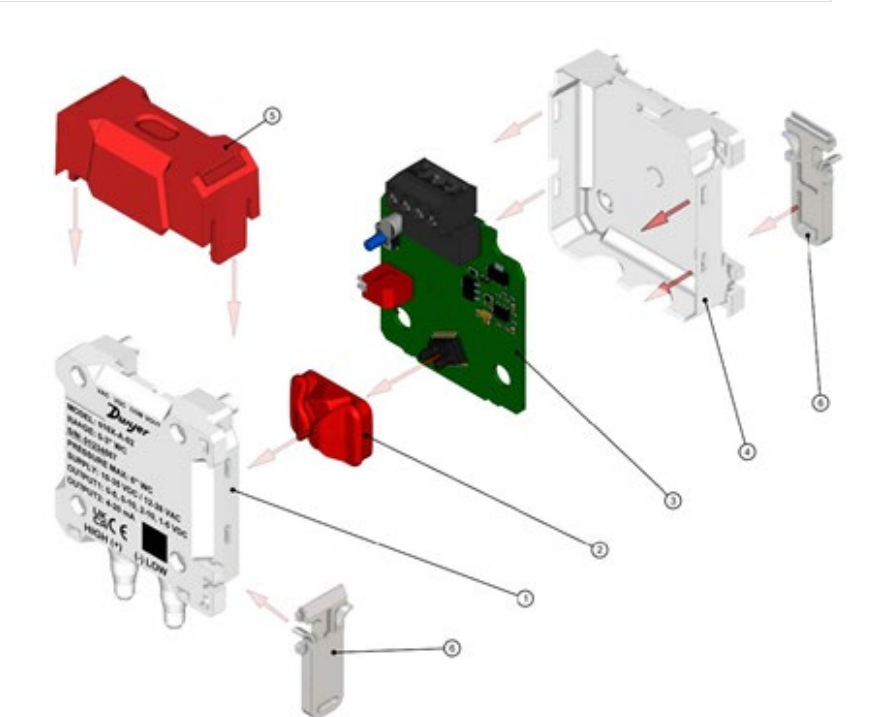
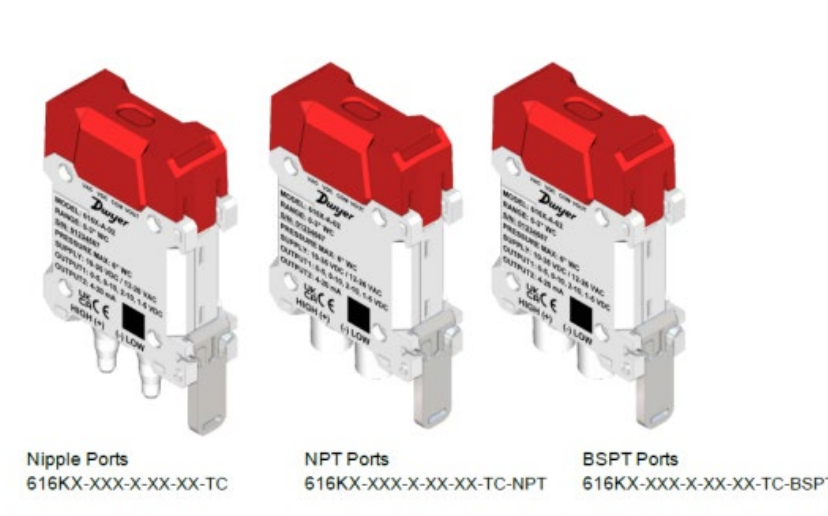

The BOM and materials for the 3 similar samples are below (Nipple Port).					
PN	Item	Rev.	Description	Qty	Material
411563-00	1	0	616KX Housing Top	1	MAKROLON 6487
411566-00/10	2	0	616KX Manifold - Silicone	1	SILICONE
204982-10, 204984-10	3	1	616KX PCB – TE/Honeywell	1	FR4
411564-00	4	0	616KX Housing Bot	1	MAKROLON 6487
411565-00	5	0	616KX Housing Cap (Term Cover)	1	MAKROLON 6487

**METHOD:**

The tests were conducted in accordance with the test procedure described in UL Standard 2043, Fifth Edition, dated September 14, 2023 – “Fire Test for Heat and Visible Smoke Release for Discrete Products and Their Accessories Installed in Air-Handling Spaces” and CAN/ULC-S142, Standard Method of Fire Test for Heat and Visible Smoke Release for Discrete Products , First Edition, dated September 2016 – R2021. This test method is used to determine the heat release rate, smoke release and optical density of the samples. The test samples were positioned and installed in the test enclosure as described in Appendix A.

**ACCEPTANCE CRITERIA:**

Per the requirements of UL 2043, each product specimen shall have the following properties when tested as described herein:

- a) The peak rate of heat release measured during each test shall be 100 kilowatts or less, HRRs.
- b) The peak smoke release rate measured during each test shall be 0.21 m<sup>2</sup> /s or less, SRRs.
- c) The total smoke released (10 minute test duration) shall be 75 m<sup>2</sup> or less, TSR.

Per the requirements of CAN/ULC-S142, each product specimen shall have the following properties when tested as described herein:

- a) The peak rate of heat release measured during each test shall be 100 kilowatts or less.
- b) The peak normalized optical density measured during each test shall be 0.50 or less.
- c) The average normalized optical density (10 minute test duration) shall be 0.15 or less.

Note: The above criteria do not include the contribution of the propane ignition burner.

**RESULTS:**

The summary of test results is tabulated in Table 2 below. Graphs of heat release rate, smoke release rate, and normalized optical density are given in Appendix B. Pre and post-test photographs for each test are given in Appendix A. In addition, video records can be provided upon request.

Table 2 - Test Results

<b>Sample - Test Ref.</b>	<b>Peak Heat Release Rate (kW)</b>	<b>Peak Normalized Optical Density</b>	<b>Average Normalized Optical Density</b>	<b>Peak Smoke Release Rate (m<sup>2</sup> /s)</b>	<b>Total Smoke Released (m<sup>2</sup> )</b>
A-1	10	0.16	0.02	0.07	10.9
A-2	13	0.25	0.02	0.10	8.8
A-3	17	0.20	0.01	0.08	6.3

Please note that the values in Table 2 above as well as the graphs in Appendix B omit the heat and smoke contribution from the propane ignition burner.

**CONCLUSION:**

The product, identified by the test sponsor as shown in Table 1 - Sample Description, in the form it was submitted to UL LLC, was evaluated in accordance with UL2043 and CAN/ULC-S142 standards and it was found compliant with standard's requirements.

**COMPLETION OF INVESTIGATION**

Since this completes the anticipated work, we have instructed our Accounting Department to terminate the investigation and invoice you for the charges incurred to date.

If you have any questions, please do not hesitate to contact the undersigned.

Very truly yours

Reviewed by:

DAN BOGDAN (847)-664-1229  
Building Materials & Systems  
Daniel.Bogdan@ul.com

ANISH CHACKO (847)-664-1273  
Building Materials & Systems  
Anish.Chacko@ul.com

## APPENDIX A

### TEST NOTES:

File SV31316, Project 4791482734

#### TEST A-1

10152405

**Sample Description:** 616KX - NPT Version

**Test Notes:** The sample was positioned on fine wire mesh and situated above the center of the test burner. The sample was placed face up.

**Post Test Observations:** The sample was still burning with light smoke at the conclusion of the test.

#### **Photos:**

**Pre-Test**

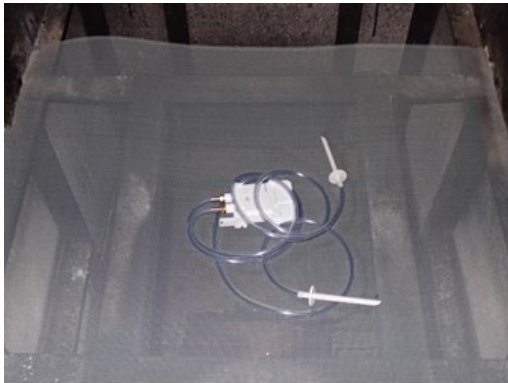

**Post-Test**



**TEST A-2**

10152406

**Sample Description:** 616KX - NPT Version

**Test Notes:** The sample was positioned on fine wire mesh and situated above the center of the test burner. The sample was placed face down.

**Post Test Observations:** The sample was still burning with light smoke at the conclusion of the test.

**Photos:**

**Pre-Test**

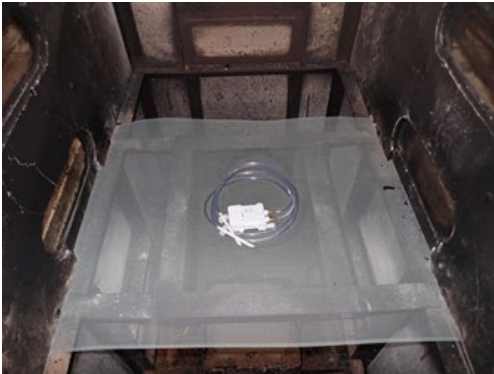

**Post-Test**



**TEST A-3**

10152407

**Sample Description:** 616KX - NPT Version

**Test Notes:** The sample was positioned on fine wire mesh and situated above the center of the test burner. The sample was placed Vertical.

**Post Test Observations:** No burning, only light smoke at the conclusion of the test.

**Photos:**

**Pre-Test**



**Post-Test**



**APPENDIX B**

**GRAPHICAL DATA**

**File SV31316, Project 4791482734**



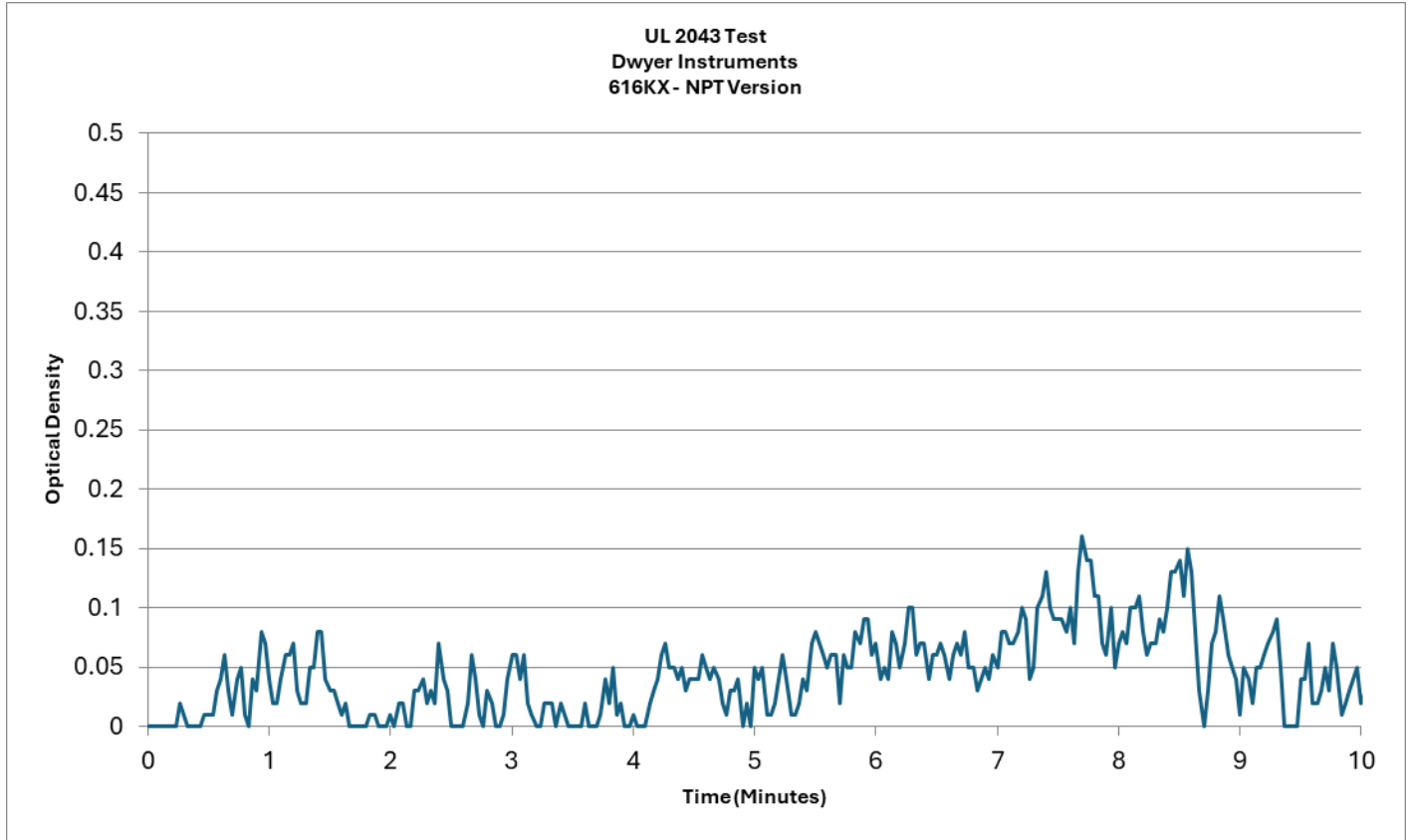

<b>Test Number</b>	<b>Test Code</b>	<b>Description</b>	<b>Peak Normalized Optical Density</b>	<b>Average Normalized Optical Density</b>
A-1	10152405	616KX - NPT Version	0.16	0.02

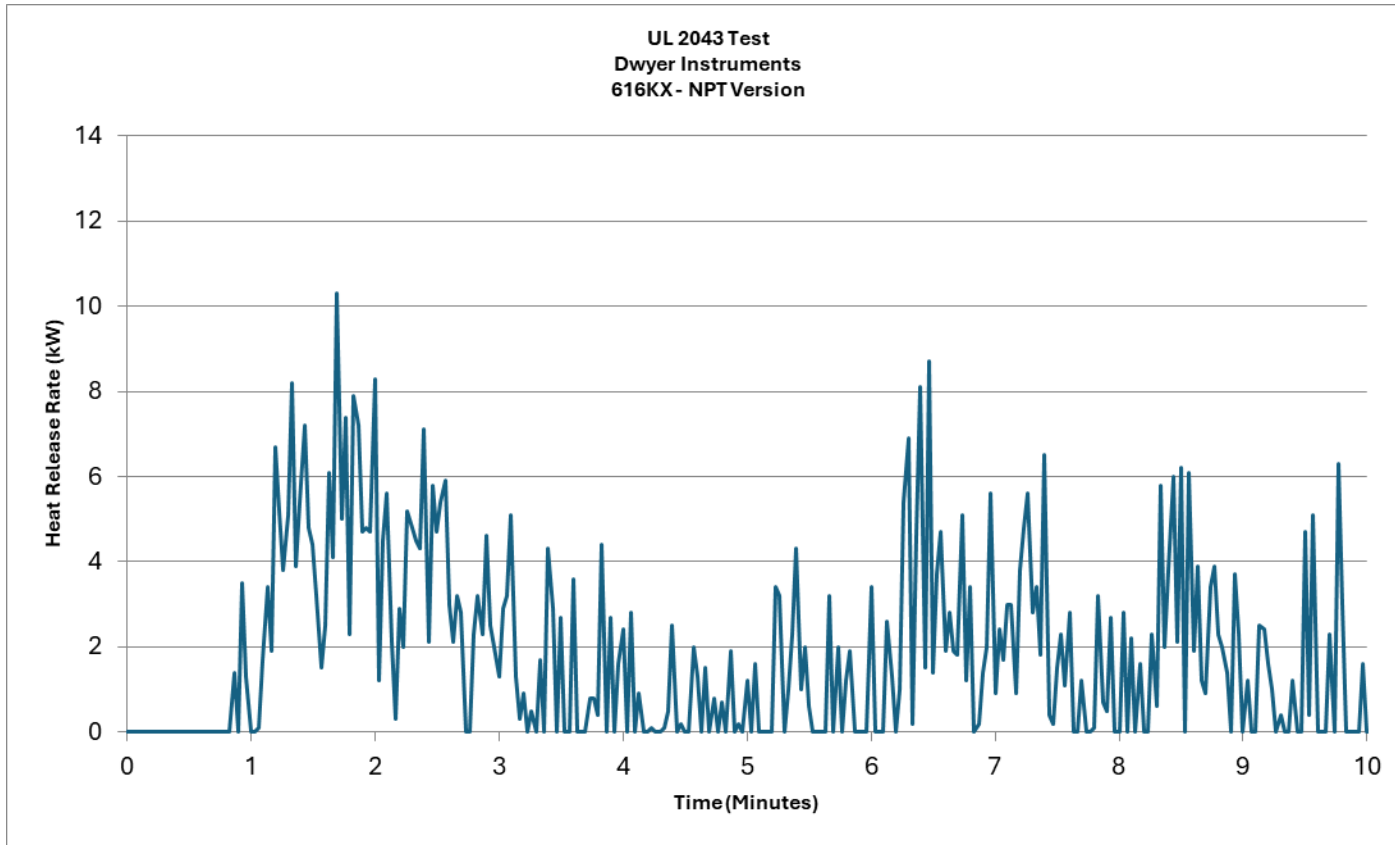

Test Number	Test Code	Description	Peak Heat Release Rate (kW)
A-1	10152405	616KX - NPT Version	10

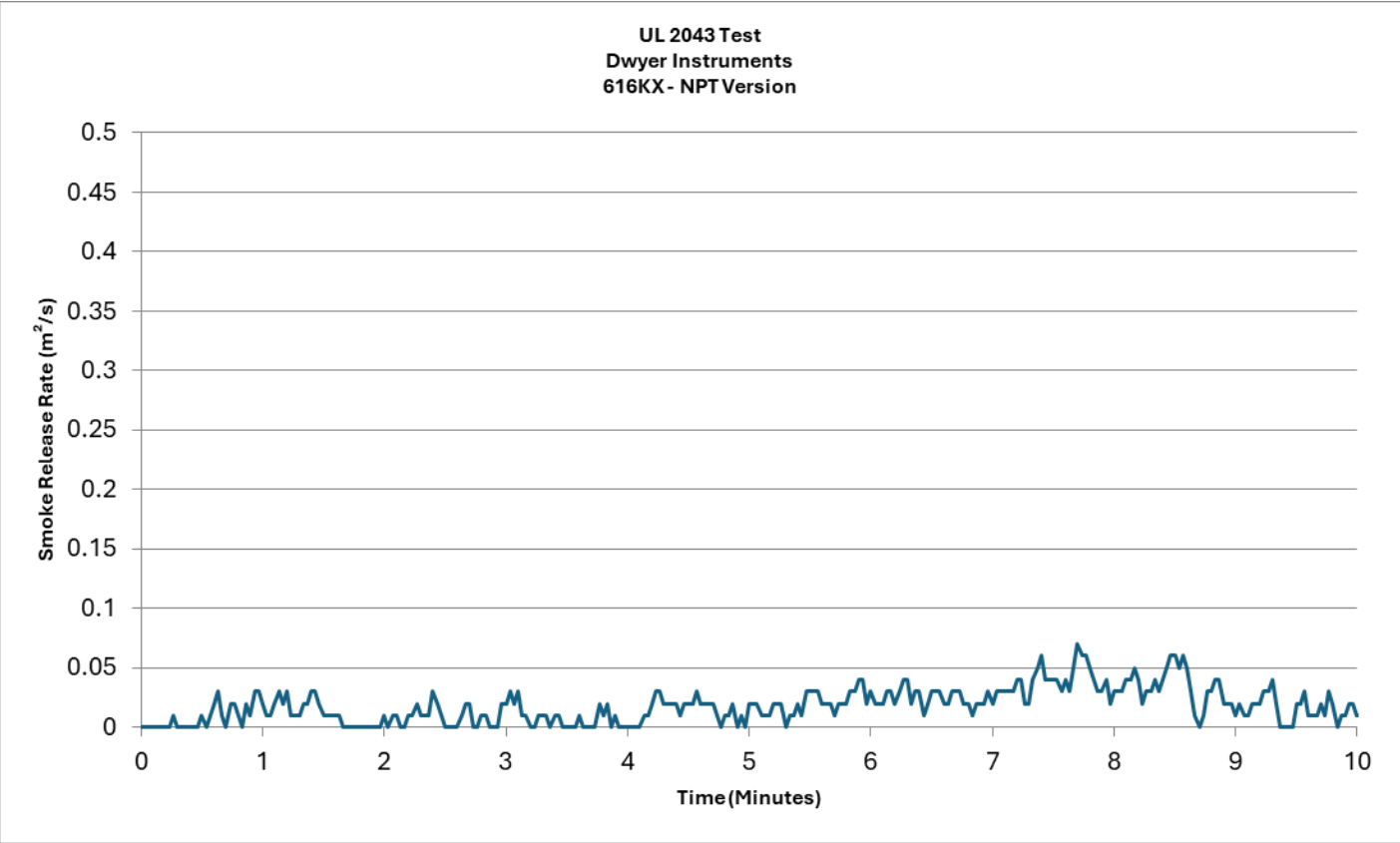

Test Number	Test Code	Description	Peak Smoke Release Rate (m <sup>2</sup> /s)	Total Smoke Released (m <sup>2</sup> )
A-1	10152405	616KX - NPT Version	0.07	10.9

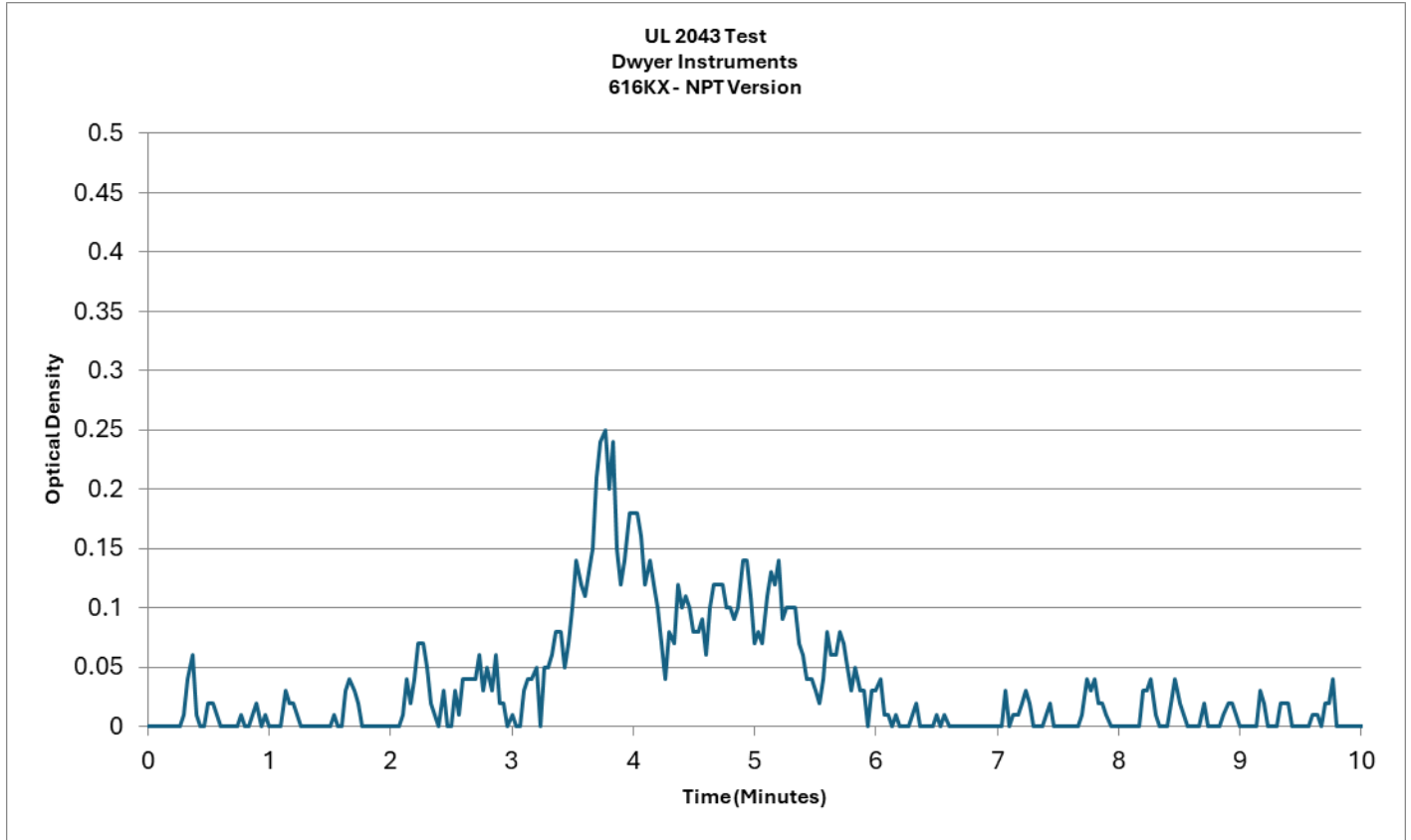

<b>Test Number</b>	<b>Test Code</b>	<b>Description</b>	<b>Peak Normalized Optical Density</b>	<b>Average Normalized Optical Density</b>
A-2	10152406	616KX - NPT Version	0.25	0.02

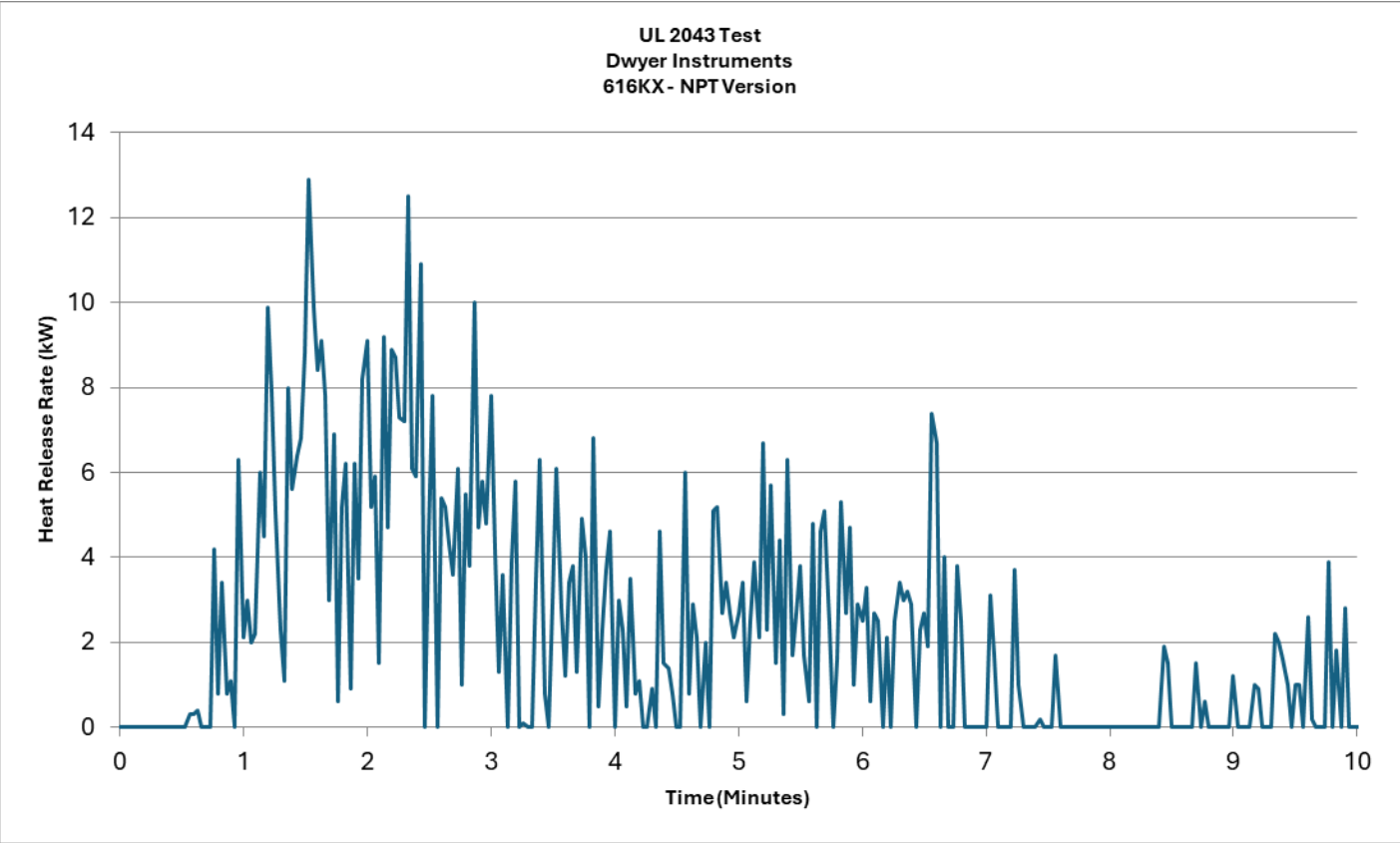

<b>Test Number</b>	<b>Test Code</b>	<b>Description</b>	<b>Peak Heat Release Rate (kW)</b>
A-2	10152406	616KX - NPT Version	13

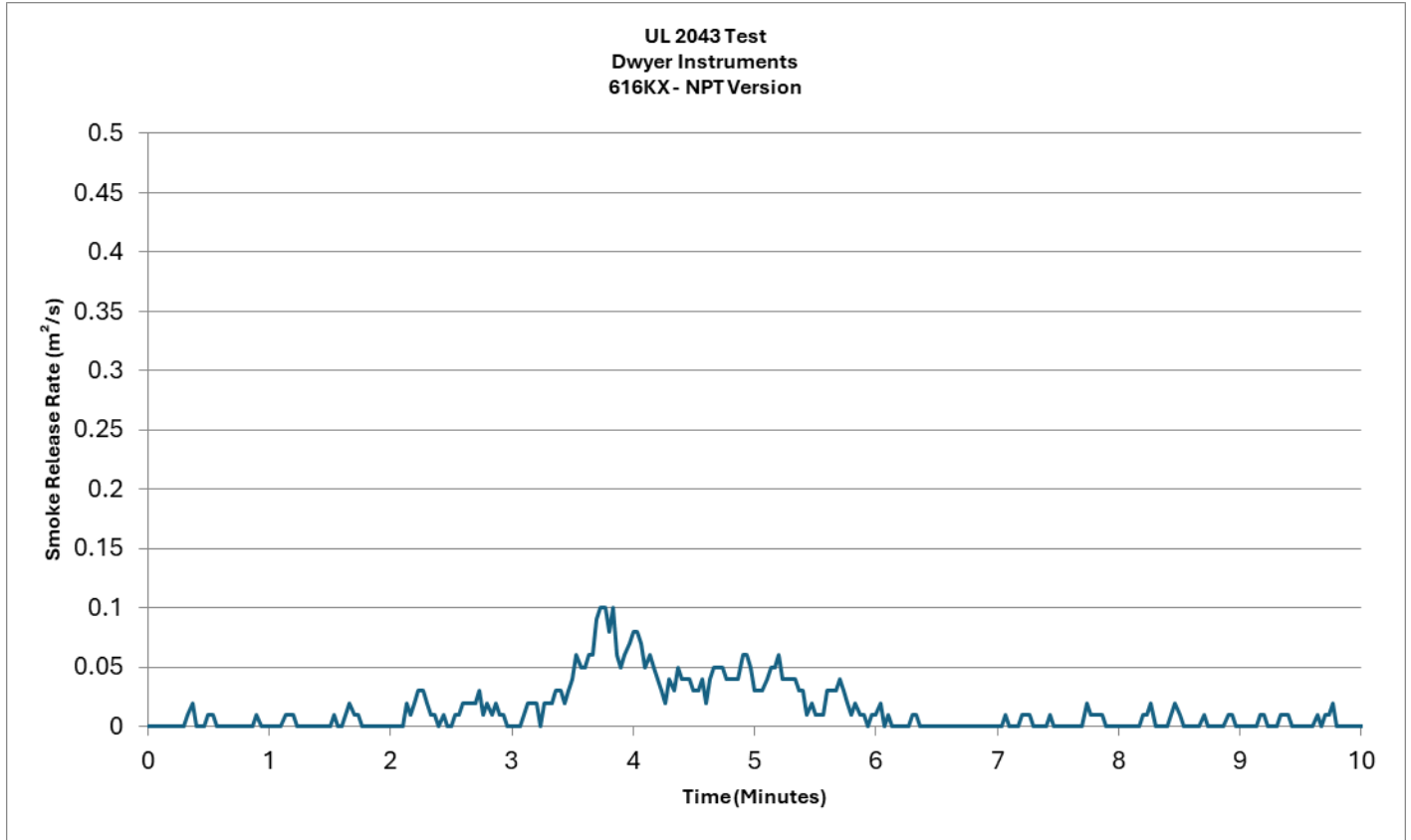

Test Number	Test Code	Description	Peak Smoke Release Rate (m <sup>2</sup> /s)	Total Smoke Released (m <sup>2</sup> )
A-2	10152406	616KX - NPT Version	0.10	8.8

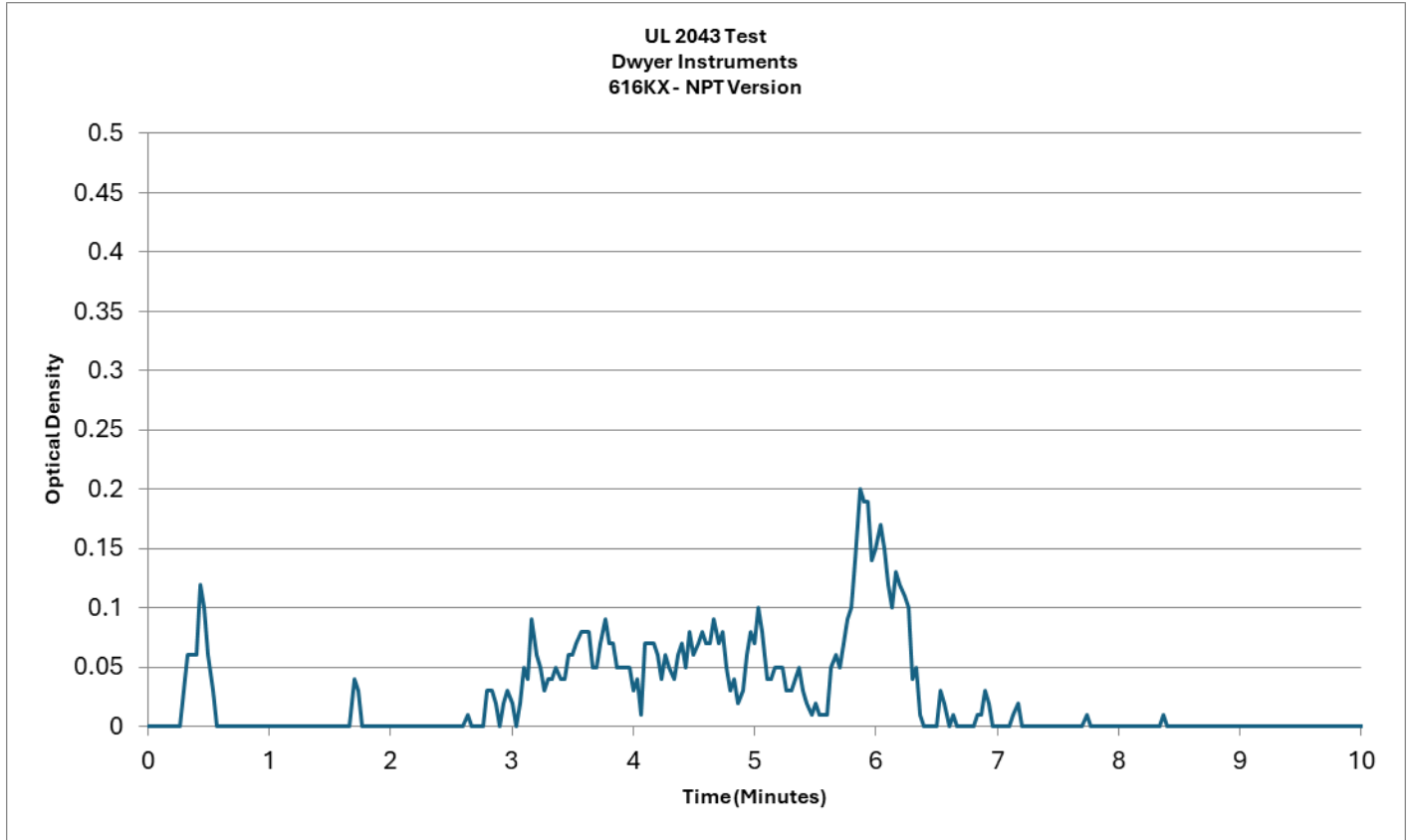

Test Number	Test Code	Description	Peak Normalized Optical Density	Average Normalized Optical Density
A-3	10152407	616KX - NPT Version	0.20	0.01

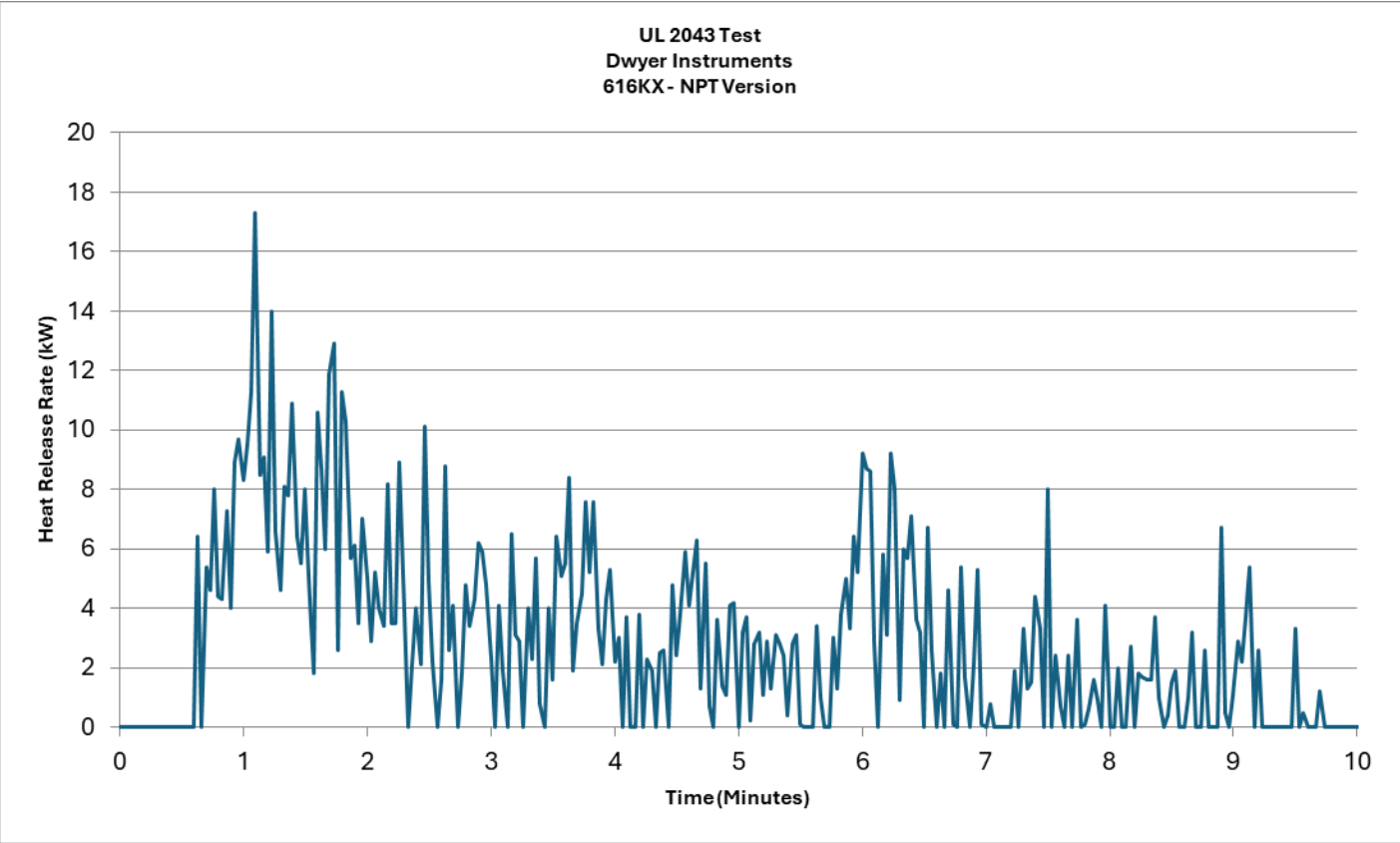

Test Number	Test Code	Description	Peak Heat Release Rate (kW)
A-3	10152407	616KX - NPT Version	17



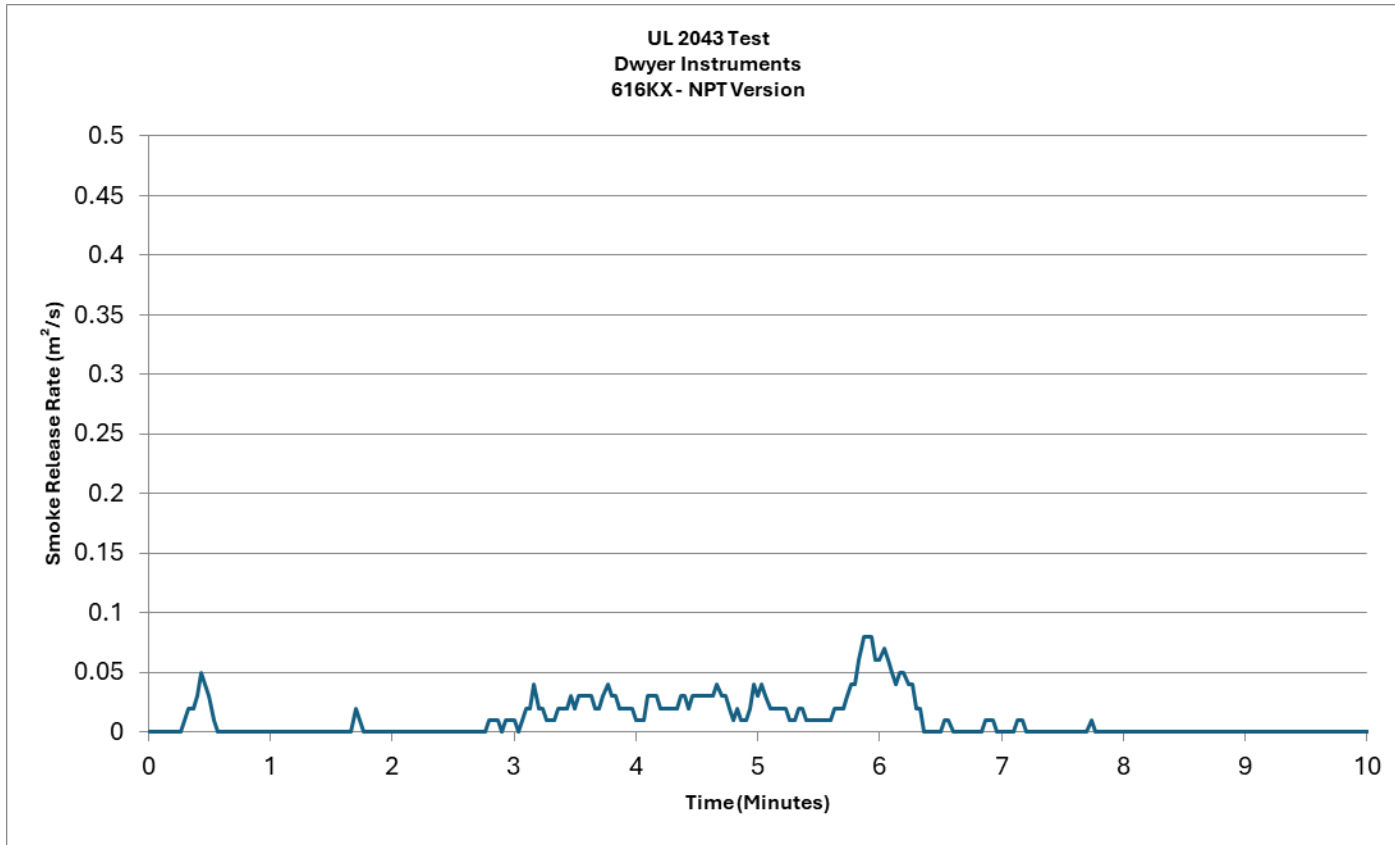

Test Number	Test Code	Description	Peak Smoke Release Rate (m <sup>2</sup> /s)	Total Smoke Released (m <sup>2</sup> )
A-3	10152407	616KX - NPT Version	0.08	6.3