

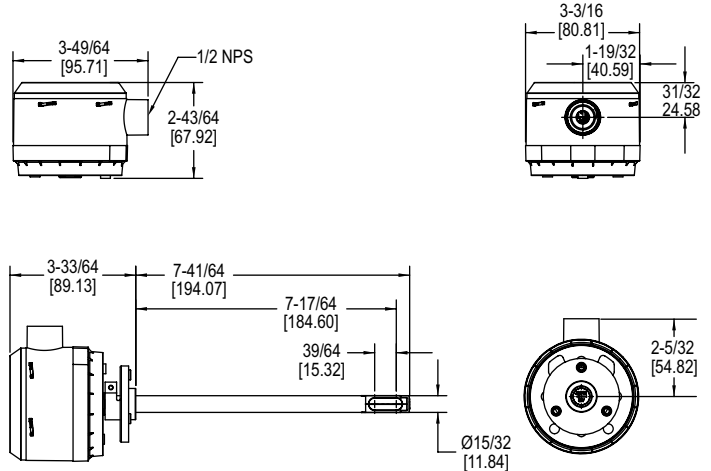

# Series AVLV Low Air Velocity Transmitter with BACnet Communication

## Specifications - Installation and Operating Instructions



The **Series AVLV Low Air Velocity Transmitter** quickly and accurately measures air velocity or volumetric flow in imperial or metric units. Simultaneous current and voltage outputs on all models provide universal inputs to monitoring equipment while the output range, units, and 0-5/10 VDC output can be configured via local DIP switches. The optional integral display, or the portable remote display tool, provide a convenient way to locally monitor process values and configure the unit.

Models are available in 1% and 2% accuracy models and low velocity ranges to suit a variety of needs, and the optional BACnet MS/TP or Modbus® RTU/ASCII communication protocol allows units to be daisy-chained while providing access to all of the velocity and flow data, as well as additional information such as air temperature. The lower ranges in these high accuracy units allow for applications in quality intensive environments, such as the pharmaceutical industry.

SPECIFICATIONS	
<b>Service:</b> Clean air and non-combustible, compatible gases.	
<b>Wetted Materials:</b> Consult factory.	
<b>Range:</b> 100, 200, 300, 400 FPM (0.5, 1, 1.5, 2.0 m/s); field selectable.	
<b>Accuracy:</b> See chart.	
<b>Temperature Limits:</b> 32 to 122°F (0 to 50°C).	
<b>Power Requirements:</b> 24 VDC ±20% or 24 VAC ±20%.	
<b>Humidity Limits:</b> 5 to 95% RH, non-condensing.	
<b>Output Signals:</b> 4-20 mA, 0-5 VDC, 0-10 VDC.	
<b>Response Time (90%):</b> 4 s, typical; 1 s at constant temperature.	
<b>Zero and Span Adjustments:</b> Digital push buttons.	
<b>Output Load Resistance:</b> Current output: 0 to 1100 Ω max.; Voltage output: Minimum load resistance 1 kΩ.	
<b>Current Consumption:</b> 60 mA max.	
<b>Display:</b> 5 digit LCD (optional).	
<b>Electrical Connections:</b> Analog: Power and output: four wire removable European style terminal block for 16 to 26 AWG; Communication: Connections: BACnet MS/TP or Modbus® RTU/ASCII: three wire removable European style terminal block for 16 to 26 AWG.	
<b>Supported Communication Baud Rates:</b> 9600, 19200, 38400, 57600, 76800, 115200 (optional).	
<b>Device Load:</b> 1/8 unit load.	
<b>Electrical Entry:</b> 1/2" NPS thread; Accessory: Cable gland for 5 to 10 mm diameter cable, A-151.	
<b>Enclosure Rating:</b> NEMA 4X (IP66).	
<b>Mounting Orientation:</b> Flow direction must be parallel to the sensor tip.	
<b>Weight:</b> 6.0 oz (160 g).	
<b>Agency Approval:</b> BTL, CE.	

ACCURACY CHART	
Velocity Range	Accuracy Rating*
20 to 100 FPM (0.15 to 0.5 m/s)	± (2% of reading + 0.04 m/s [7.9 FPM]) ± (1% of reading + 0.04 m/s [7.9 FPM])
20 to 200 FPM (0.15 to 1.0 m/s)	± (2% of reading + 0.04 m/s [7.9 FPM]) ± (1% of reading + 0.04 m/s [7.9 FPM])
20 to 300 FPM (0.15 to 1.5 m/s)	± (2% of reading + 0.05 m/s [9.8 FPM]) ± (1% of reading + 0.05 m/s [9.8 FPM])
20 to 400 FPM (0.15 to 2.0 m/s)	± (2% of reading + 0.06 m/s [11.8 FPM]) ± (1% of reading + 0.06 m/s [11.8 FPM])

\*Accuracy dependent on model selected when ordering.

## INSTALLATION

### Duct Mount:

The transmitter should be mounted away from fans, corners, heating and cooling coils, and other equipment that will effect the measurement of the air velocity. It is recommended that the AVLV is mounted 10 duct diameters downstream of any disturbances and 5 duct diameters upstream of any disturbances, if possible.

1. Mark and drill a 0.750-0.938" (20-24 mm) diameter hole into the duct.
2. Insert and center the duct mount flange in the previously drilled hole and mark location of the three mounting screw holes.
3. Remove the mounting flange and drill or punch the mounting holes in the marked locations.
4. Fasten the flange to the duct using three #8 x 1/2 pan head sheet metal screws. Do not over tighten screws.
5. Insert the AVLV probe into the ducts mount flange and set the desired insertion depth.
6. Note the flow direction and unit alignment as shown on sensor tip and product label, tighten probe retention set screw on the duct mount flange screw to affix the probe in place.

### Electrical Connection:

The Series AVLV is powered and simultaneously transmits a two-wire 4-20 mA current output and a three-wire 0-5 VDC or 0-10 VDC voltage output via a removable four conductor terminal block. The transmitter power supply common is used to reference the current and voltage outputs so either current, voltage, or current and voltage may be wired according to the application. The range of the voltage output can be selected using the on board DIP switches as described in the Analog DIP Switch Settings section of this manual.

### Power Supply

Choose a power supply with a voltage and current rating sufficient to meet the power specifications under all operating conditions. If the power supply is unregulated, make sure the output voltage remains within the required voltage range under all power line conditions. Ripple on the supply should not exceed 100 mV.

**CAUTION** DO NOT EXCEED SPECIFIED SUPPLY VOLTAGE RATINGS. PERMANENT DAMAGE NOT COVERED BY WARRANTY WILL RESULT.

### Current Output Operation

**CAUTION** DO NOT EXCEED SPECIFIED SUPPLY VOLTAGE RATINGS. PERMANENT DAMAGE NOT COVERED BY WARRANTY WILL RESULT.

The terminal block is removable, and each of the terminals are labeled underneath the terminal block on the circuit board. As the power supply and outputs share the same common signal (GND), the outputs may have separate wires but must effectively join at terminal 2 of the transmitter, as shown in Figure 1. The connections to the transmitter are made to terminals 1, 2, and 3 (PWR, GND, and IOU respectively) on the terminal block as shown in Figure 4.

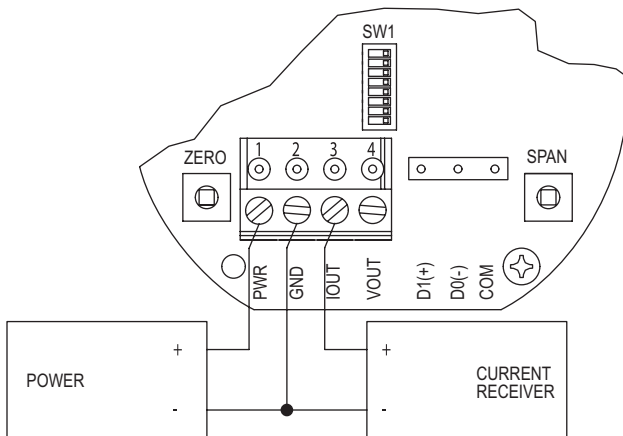

Figure 1: Current output wiring

Although low loop resistances are recommended, the absolute maximum current loop load resistance,  $R_{MAX}$ , is defined by the following equation:

$$R_{MAX} = (V_{PS} - 2.0) / 0.02 \text{ where } V_{PS} \text{ is the power supply voltage}$$

For a 24 VDC nominal power supply, this evaluates to  $R_{MAX} = 1100$  ohms.

Shielded two wire cable is recommended for current output loop wiring. Ground the shield at the power supply end only.

The maximum length of connecting wire between the current transmitter and the receiver is a function of wire size and receiver resistance. That portion of the total current loop resistance represented by the resistance of the connecting wires themselves should not exceed 10% of the receiver resistance. For extremely long runs (over 1,000 ft.), it is desirable to select receivers with higher resistances in order to keep the size and cost of the connecting leads as low as possible. In installations where the connecting run is no more than 100 ft, connecting lead wire as small as No. 22 Ga. can be used.

### Voltage Output Operation

**CAUTION** DO NOT EXCEED SPECIFIED SUPPLY VOLTAGE RATINGS. PERMANENT DAMAGE NOT COVERED BY WARRANTY WILL RESULT.

The terminal block is removable, and each of the terminals are labeled underneath the terminal block on the circuit board. The voltage output and the power supply must have separate wire leads that are only joined at terminal 2 of the transmitter, as shown in Figure 2. Additional error may occur for the voltage output if a single wire is used or if the wires are joined at the power supply or receiver. The connections to the transmitter are made to terminals 1, 2, and 4 (PWR, GND, and VOUT respectively) on the terminal block as shown in Figure 4.

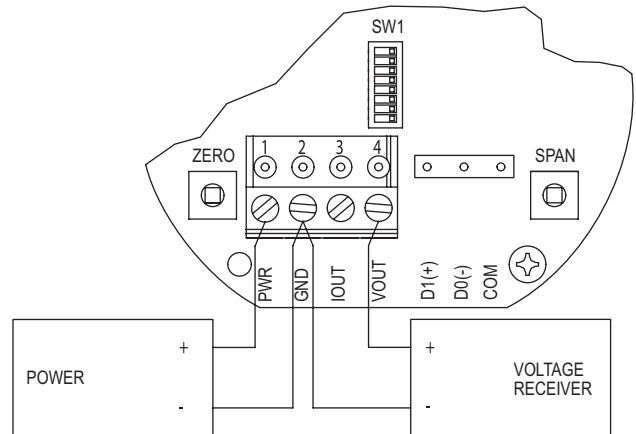

Figure 2: Voltage output wiring

The minimum receiver load is 1 kΩ. The resistance due to the wire should be low compared to the receiver load resistance. While the voltage at the terminal block remains unchanged with a 10 mA current flow, resistive losses in the wiring do cause errors in the voltage delivered to the receiver. For a 1% accurate gauge, the resistance of the wires should be less than 0.1% of the value of the receiver load resistance. This will keep the error caused by the current flow below 0.1%.

The output across VOUT and COM will be either 0-5 VDC, 0-10 VDC, or the inverse depending on the DIP switch setting. See the Analog DIP Switch Settings section for more information.

### Simultaneous Current and Voltage Output Operation

**CAUTION** DO NOT EXCEED SPECIFIED SUPPLY VOLTAGE RATINGS. PERMANENT DAMAGE NOT COVERED BY WARRANTY WILL RESULT.

The terminal block is removable, and each of the terminals are labeled underneath the terminal block on the circuit board. The voltage output and the power supply must have separate wire leads that are only joined at terminal 2 of the transmitter, as shown in Figure 3. Additional error may occur for the voltage output if a single wire is used or if the wires are joined at the power supply or receiver. The connections to the transmitter are made to terminals 1, 2, 3 and 4 (PWR, GND, IOU, and VOUT respectively) on the terminal block as shown in Figure 4, which reflects both the 4-20 mA and 0-5/10 VDC outputs in the same circuit. Details of each output are detailed in their electrical connection sections.

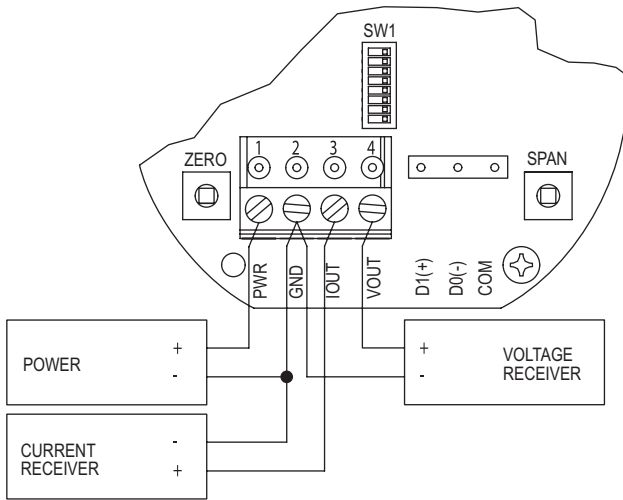

Figure 3: Simultaneous current and voltage output wiring

**ANALOG DIP SWITCH SETTINGS**

The analog output DIP switches (SW1) are located above the terminal blocks on the left as shown in Figure 4. A small screw driver or pen can be used to change the position of the switches as required.

**CAUTION** All power should be turned off to the transmitter before adjusting the DIP switch settings to avoid electrical shock.

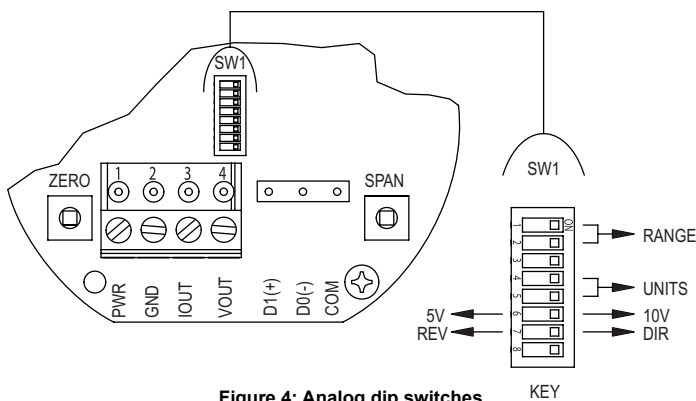

Figure 4: Analog dip switches

**Factory Default Settings (DIP SW1 – All Switches ON)**

Range = Highest Range Setting (400 FPM)  
 Units = Imperial (FPM)  
 Voltage Output Range = 0-10 VDC  
 Direct / Reverse Output Action = Direct

**Setting the Air Velocity Range**

The range of the instrument is selected by using DIP switches 1 and 2 on SW1. Table 1 shows the maximum full scale value for the selected range and unit. Refer to Setting the Engineering Units section for information on setting the unit.

DIP Switch SW1		Full Scale Range	
1	2	Imperial (FPM)	Metric (m/s)
ON	ON	400	2
ON	OFF	300	1.5
OFF	ON	200	1
OFF	OFF	100	0.5

Table 1: DIP Switch SW1 Settings for Full Scale Range

**Setting the Engineering Units**

The Series AVLV can be configured to indicate velocity in imperial (FPM, CFM) or metric (m/s, m³/h) units using DIP switches 4 and 5 on SW1, and Table 2 shows the values. The units will be displayed on the optional LCD display if connected.

DIP Switch SW1		Units	
4	5	Velocity Mode	Air Flow Mode
ON	ON	FPM	CFM
ON	OFF	m/s	m³/h
OFF	ON	m/s	m³/h
OFF	OFF	m/s	m³/h

Table 2: DIP Switch SW1 Settings for Units

The default operating mode is velocity, but changes can be made, such as flow mode, via the menu system while an optional display or remote display accessory is connected. Please refer to Appendix VII for a full menu flow chart.

**Setting the Output Voltage Range**

Voltage Output can be either 0-5 VDC or 0-10 VDC depending on the position of DIP Switch 6 ON SW1.

- When the switch is in the ON position, the output will be 0-10 VDC.
- When the switch is in the OFF position, the output will be 0-5 VDC.

**Setting the Input / Output Action**

The output will either follow the process directly (DIRECT) or inverted (REVERSED) based on the position of DIP Switch 7 on SW1.

- When the switch is in the ON position, the output directly follows the input (i.e. output increases as the input increases).
- When the switch is in the OFF position, the output acts in reverse of the input (i.e. output decreases as the input increases).

**CALIBRATION**

**NOTICE** There is a 5 second delay from the time the zero or span calibration buttons are released until the time that the change in calibration takes place. This delay is used to reduce vibration or disturbances of the user related to the button presses.

**NOTICE** The security level that is set in the Programming Menu section of the manual will determine which calibrations, if any, may be adjusted by the user.

**Zero Calibration**

The zero calibration can be set by covering the sensor to ensure no air flow and pressing the zero button for 3 seconds. If either the remote or local LCD is present, the display will read *ZERO* and then sequence back to the home display.

**SPAN Calibration**

The span calibration can be adjusted only after setting the zero adjustment. It must be completed within 5 minutes of the last zero calibration. The span calibration button will be ignored until the zero calibration is completed. Place the sensor in airflow that matches the maximum selected range of the transmitter. Press and hold the span button for 3 seconds. If either the remote or local LCD is present, the display will read *SPAN* and then sequence back to the home display. If the span calibration is attempted before adjusting the zero calibration, the *FAIL* error message will be displayed briefly before returning to the home display.

**LCD Display**

The Series AVLV can be ordered with an optional, integral LCD. It comes with a housing cover and overlay to protect the display. The display will plug into the pins as shown in Figure 5. If the display is not needed for normal operation, the transmitter can be ordered without the LCD.

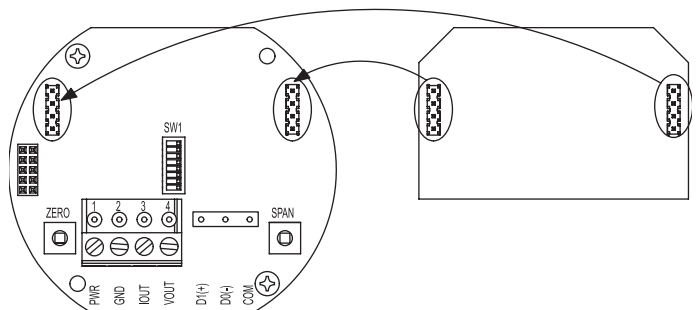

Figure 5: Pluggable display diagram

Another option for models that do not have a display would be to use a Model A-435-A remote display tool which can plug into the connector shown in Figure 6. The remote display tool has two buttons that function identically to the buttons on the PCB.

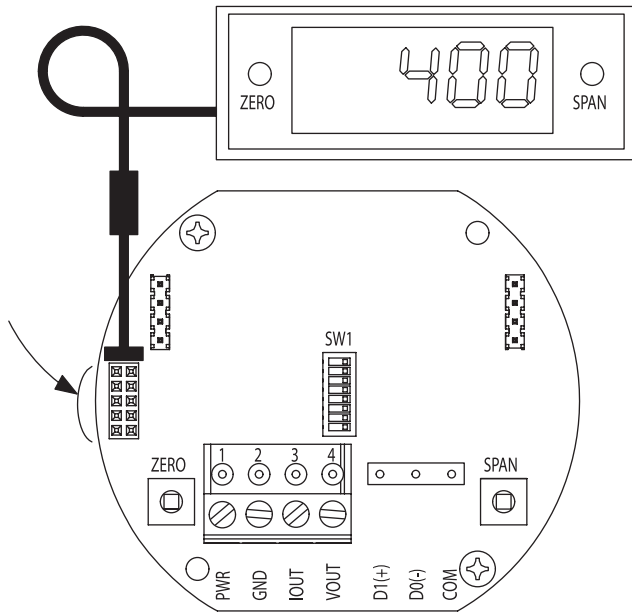

Figure 6: Remote display diagram

**Display Error Messages**

**OVER** = The air velocity is greater than the maximum span value causing an Over Range Error

**UNDER** = The air velocity is less than the minimum span value causing an Under Range Error

**FAIL** = When the span or zero buttons are pressed, the air velocity value is out of the range to allow a correct setting. This may be due to a sensor failure.

**ERR1** = The sensor is damaged.

**PROGRAMMING MENUS**

**Home Menu**

During normal operation, the display will be in the Home Menu and will display the current measured pressure and the engineering units.

**Menu Access Security**

While in the Home Menu, press and hold the Zero and Span buttons simultaneously until **SECUR** appears on the display in order to access the other programming menus. Upon releasing the buttons, the display will indicate the current security level.

If the current security level is the security level desired (i.e. Security Level 0), press and hold the span button for 3 seconds to enter the Velocity or Air Flow Menu.

If the security level is not the desired level, the security level can be changed temporarily to a lower security level or permanently to a higher level of security by pressing the zero button. A security code will appear on the display, and it can be changed to one of the codes listed in Table 3. The span button chooses which digit and the zero button increments the value of that digit. Pressing and holding the span button will store the value.

The level of access to the programming menus and the calibration is limited based on the security level. Table 3 details the level of access for each security level.

Security Level	Setting	Access			
		View Menu	Edit Menu	Span	Zero
0	000	Yes	Yes	Yes	Yes
1	111	Yes	No	No	Yes
2	222	No	No	No	No
3	333	No	No	No	No

Table 3: Security Settings

**Mode Selection / Digital Dampening Menu**

From the home display, pressing the span and zero button simultaneously for 3 seconds will access the Menu Security Level. If the level is set to 0 or 1, pressing and holding the span button for 3 seconds, a second time, will access the Mode Selection Menu. The display will default to air velocity when first powered up. Pressing the zero button will cycle to air flow.

Once the desired mode is displayed, pressing and holding the span button for 3 seconds will save the selected mode and display the digital dampening or averaging parameter. This parameter stabilizes the output and the display by averaging the readings. There are 2.5 readings taken each second and the user can select the number of seconds that they would like to average, up to 240 seconds. The display and the output will continue to update at a rate of 2.5 updates per second, but the moving average is used for these updates.

**Velocity Mode**

**K-Factor Adjustment**

If the Velocity Mode was selected, pressing and holding the span after adjusting the digital dampening will enter the Velocity Mode and the transmitter will display the engineering unit that has been selected by the DIP switch. Pressing and holding the span button for 3 seconds will enter the K – Factor adjustment. The K – Factor can be adjusted between 0.001 to 9.999. The K-Factor can be adjusted by pressing the span button to select the digit and pressing the zero button to increment the value of the digit. Pressing and holding the span button for 3 seconds will enter the Maximum Output Adjustment parameter.

**Flow Mode**

**K-Factor Adjustment**

If the Flow Mode was selected, pressing and holding the span after adjusting the digital dampening will enter the Flow Mode and the transmitter will display the engineering unit that has been selected by the DIP switch. Pressing and holding the span button for 3 seconds will enter the K-Factor adjustment. The K-Factor can be adjusted between 0.001 to 9.999. The K-Factor can be adjusted by pressing the span button to select the digit and pressing the zero button to increment the value of the digit. Pressing and holding the span button for 3 seconds will enter the Area Adjustment parameter.

**Area Adjustment**

For flow applications, the area is multiplied by the velocity to determine the volumetric air flow. The area will be listed in either CFM or m<sup>3</sup>/h depending on the DIP switch settings. The units will appear on the display at the time of adjustment. The area can be adjusted by pressing the span button to select the digit and pressing the zero button to increment the value of the digit. Pressing and holding the span button for 3 seconds will enter the Maximum Output Adjustment parameter.

**Maximum Output Adjustment**

The maximum output can be equivalent to air velocity or air flow. After adjusting the K-Factor, the display will indicate if the adjustment is set for velocity or air flow. Pressing the zero button will toggle between the selections. Pressing and holding the span button for 3 seconds will enter the maximum output adjustment. The maximum output can be adjusted by pressing the span button to select the digit and pressing the zero button to increment the value of the digit. Pressing and holding the span button for 3 seconds will save this value and go to the Security Update Menu.

**Security Update / Save Changes Menu**

The Security Update Menu allows the security level to be set either higher or lower than the current security level setting. This security level will be displayed the next time the Menus are accessed from the home screen. Pressing the zero button cycles through the security levels. Pressing and holding the span button for 3 seconds accepts the new security level and gives the option to save all the menu changes. Pressing the zero button will toggle between yes and no. Yes will save the changes made to all menu items and no will discard all the changes made to all menu items. If the display is set to yes, pressing and holding the span will save the menu items and return the display to the home position.

**FACTORY DEFAULT PROCEDURE**

In order to reset all of the menu settings back to their factory programmed values, press and hold both the span and zero buttons simultaneously for 10 seconds until **FACT** is displayed on the LCD. Upon releasing the buttons, the unit will be factory defaulted. Since resetting the transmitter will wipe out all changes, it is necessary to zero (and possibly span) the transmitter before taking measurements.

**MAINTENANCE/REPAIR**

Upon final installation of the Series AVLV Air Velocity Transmitter, no routine maintenance is required besides zeroing the transmitter occasionally. Besides routine calibration and installation of the LCD, the Series AVLV is not field serviceable, and it is not possible to repair the unit. Field repair should not be attempted and may void warranty.

**WARRANTY/RETURN**

Refer to “Terms and Conditions of Sales” in our catalog and on our website. Contact customer service to receive a Return Goods Authorization number before shipping the product back for repair. Be sure to include a brief description of the problem plus any additional application notes.

**APPENDIX I: Air Velocity / Air Flow Calculations**

Velocity in m/s is then calculated from the equation:

$$\text{Velocity (m/s)} = \text{Velocity (FPM)} \times 0.00508$$

Flow in m<sup>3</sup>/h is then calculated using the below equation:

$$\text{Flow (CFM)} = \text{Area (ft}^2\text{)} \times \text{K-Factor} \times \text{Velocity (FPM)}$$

$$\text{Flow (m}^3\text{/h)} = \text{Flow (CFM)} \times 1.6992$$

**APPENDIX II: Maximum Flow**

Max Flow		Max K Factor x Area	
CFM	m <sup>3</sup> /h	CFM Range	m <sup>3</sup> /h Range
5885000	9999000	14712.5	1388.75

Table 4: Maximum flow values

**APPENDIX III: BACnet MS/TP Operation**

**NOTICE** Wiring should comply with Electrical Characteristics of Generators and Receivers for Use in Balanced Digital Multipoint Systems, TIA/EIA-485-A-1998, Telecommunications Industry Association, 1998.

**NOTICE** Wiring should comply with ANSI/ASHRAE Standard 135-2010 BACnet A Data Communication Protocol for Building Automation and Control Networks, American Society of Heating, Refrigerating and Air-Conditioning Engineers, Inc., 2010.

**NOTICE** Communications wiring must be in a daisy-chain fashion. Star connections are not permitted.

**NOTICE** Cable shield must be connected to earth ground at one location only.

Figure 7 shows how to connect the AVLV in a network containing a common power supply. Use a cable containing two twisted pairs. One pair is to be used for D1(+) and D0(-). The other pair is to be used for power and common. This configuration is not suitable for AC supplies. Use a DC supply only. Care should be taken that there are not too many devices powered from the same supply as voltage drops will occur in the wiring. If you have many devices, or have long cable runs, the local supply configuration may be a better choice.

Figure 8 shows how to connect the AVLV in a network containing individual local supplies. Use a cable containing a twisted pair and a single conductor. The pair is to be used for D1(+) and D0(-). The single conductor is to be used for common. Both AC and DC supplies are suitable for this configuration.

In either configuration you must use shielded cable. The AVLV has a shield terminal for a convenient location to make connections. It is not electrically connected to the AVLV. Connect the shield to earth ground at one location only to prevent ground loops.

All devices in the network should be daisy chained. Star connections and T connections are not permitted.

The D1(+) and D0(-) lines must be terminated at both ends with a 120 ohm resistor. If the AVLV is an end device it has an on-board resistor that may be used. See BACnet MS/TP DIP Switch Settings to enable it.

The network must be biased properly. If needed, there are bias resistors on-board the AVLV. No more than two sets of bias resistors should be enabled in the network. See BACnet DIP Switch Settings to enable them.

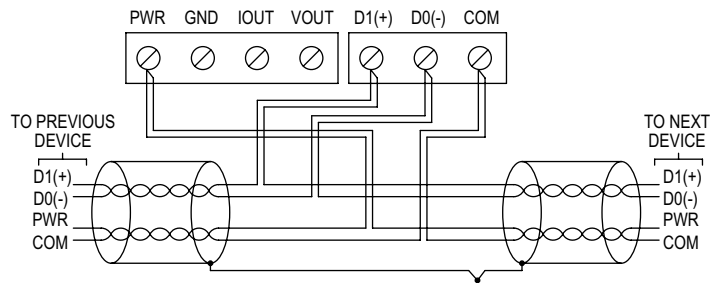

**Figure 7: Common power supply**

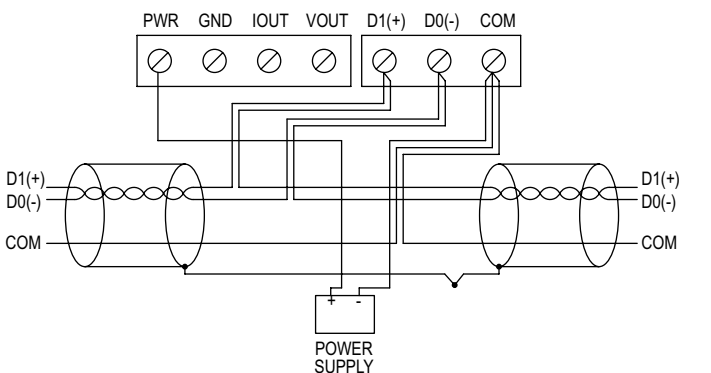

**Figure 8: Local power supply**

**BACnet MS/TP DIP Switch Settings**

Use the middle DIP Switch SW2 to configure the BACnet MS/TP MAC communication protocol address of the device. The LCD will show the address when the transmitter is powered on. Valid addresses range from 0 to 127. By default, the device is shipped with the address 127 (as shown in Figure 10). A valid and unused address should be set before connecting to an existing network. However, the address can be changed while the device is operational. If the address is changed, the device will stop responding to the currently configured address immediately. The device waits 15 seconds after the last switch change before applying the new address. The device will not function properly if an invalid address is set. The red LED will periodically blink once indicating an invalid address. The LCD will display *R ERR* when the transmitter is powered on if the address is invalid. See Appendix V for setting the BACnet MS/TP MAC address of the device. Use the right DIP Switch SW3 to configure other hardware and software options.

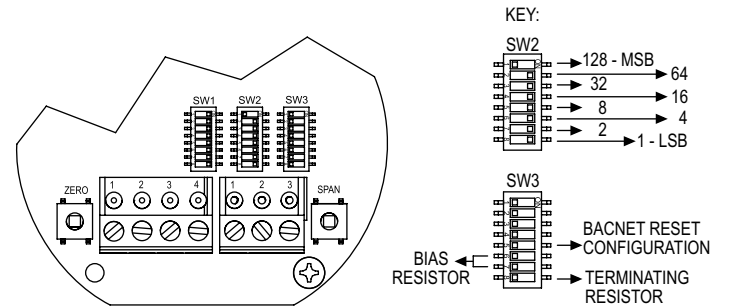

**Figure 9**

Switch	On	Off
1-2 – Display Units Selection		
3-4 – Reserved		
5 - Reset BACnet Configuration to Factory Defaults	Reset settings at Power On	Settings Preserved
6 – D1(+) Network Resistor	511Ω Pull-up to 5V	Pull-up not connected
7 – D0(-) Network Resistor	511Ω Pull-down to GND	Pull-down not connected
8 – Terminating resistor	120Ω between D0(-) and D1(+)	Open

**Table 5: DIP switch SW3 functions**

**APPENDIX IV: Programming Via BACnet MS/TP Communication Protocol**

Supported Baud Rates	Data Size	Parity	Stop Bits
9600	8	None	1
19200			
38400			
57600			
76800			
115200			

**Table 6: Supported BACnet communication protocol MS/TP configurations**

**Auto-Baud Serial Configuration**

Auto-baud serial configuration enables the device to determine the baud rate directly from the serial traffic. This allows a device to be quickly and easily deployed after a valid BACnet Communication Protocol MS/TP address is chosen.

To activate auto-baud serial configuration, set a valid BACnet Communication Protocol MS/TP address using the left DIP switch SW2, connect the serial bus and power wires, and then apply power. The device will power up and begin examining the serial bus for communication. The Red LED will repeatedly flash twice, indicating that auto-baud serial configuration is in progress.

If the device is setup offline or away from the main network, it is necessary to generate BACnet Communication Protocol MS/TP traffic in order to configure the serial communication. Initiating a Whols command is a good method to generate BACnet Communication Protocol MS/TP traffic and verify the device is working properly. Note that while serial configuration is in progress, the device may not respond to requests. The device may require multiple requests to complete the serial configuration process.

The auto-baud serial configuration process will complete once a Whols or ReadProperty command is successfully received and processed.

The auto-baud serial configuration procedure is started after a power-cycle and after a change to the MS/TP address.



**BACnet MS/TP Communication Protocol Object Overview**

Object Type	Dynamically Creatable	Dynamically Deletable	Object Identifier	Object Name
Device	No	No	607xxx	AVLV Velocity
Analog Input	No	No	AI1	Velocity FPM
			AI2	Velocity MPS
			AI3	Temperature F
			AI4	Temperature C
Analog Value	No	No	AV1	Flow CFM
			AV2	Flow CMH
			AV3	Flow Area SqFt
			AV4	Flow Area SqM
Binary Value	No	No	BV1	Zero
			BV2	Span
			BV3	Restore Factory
				Pressure Values

**Table 7: Supported BACnet MS/TP communication protocol objects**

**Device Information**

The default device object identifier is 607xxx, where xxx is replaced by the MS/TP MAC address set by the middle DIP switch SW2. The object identifier value will change as the MS/TP MAC address changes. However, if a specific object identifier is written via BACnet MS/TP Communication Protocol, then that value is stored and changes to the MS/TP MAC address will no longer affect the object identifier. See Appendix VI for the device object property tables.

**NOTICE** Changes to Max Master and Max Info frames require a power cycle/reset to take effect.

**Accessing the Measurements**

The analog input object AI1 through AI4 are for viewing Air Velocity or Temperature in the desired engineering units. The object property tables for these analog input objects can be found in Appendix VI.

Analog value object AV1 through AV4 are for viewing the Air Flow or Flow Area calculated values in the desired engineering units. The object property tables for the analog value objects can be found in Appendix VI.

**Zero Calibration**

Zero calibration can be done either with the push buttons or using BACnet MS/TP communications. The unit should have no air flowing through it. When using BACnet MS/TP communications, the binary value object (BV1) will be used to signal the transmitter to zero the reading. The present value of this object will be set to ACTIVE (1) to initiate the re-calibration of the zero point of the sensor. The zero function will only work if the current velocity is within ±2% of the span velocity of the previous zero. If the current velocity is outside of this valid band, the zero function will fail and the present value will be changed to INACTIVE (0). The zero function takes at most 10 seconds to complete. If after this time the present value remains ACTIVE (1), then the command was executed successfully. The object property tables for the binary value objects can be found in Appendix VI.

**Span Calibration**

In order to adjust the span calibration, place the unit in a flow with air velocity that is associated with the maximum end of the transmitter range. The binary value object (BV2) will be used to signal the transmitter to adjust span. The present value will be set to ACTIVE (1) to initiate the span calibration. The span calibration can be adjusted only after setting the zero adjustment. It must be completed within 5 minutes of the last zero calibration. The span calibration command will fail until the zero calibration is completed and the present value will be returned to INACTIVE (0). The span function takes at most 10 seconds to complete. If after this time, the present value remains ACTIVE (1), then the command was executed successfully. The object property tables for the binary value objects can be found in Appendix VI.

**Reset factory Defaults**

Present values for the zero, span, and area can be restored to the factory settings using the binary value object (BV3). The present value will be set to ACTIVE (1) to initiate the factory default procedure. The factory default takes at most 10 seconds to complete. If after this time, the present value remains ACTIVE (1), then the command was executed successfully. The object property tables for the binary value objects can be found in Appendix VI.

**BACnet MS/TP Communication Protocol Services**

**Device Communication Control Service (DM-DCC-B)**

This device supports the Device Communication Control Service BIBB. The optional time duration in minutes is also supported. This device is configured with a password that must be provided to successfully execute this command. The password is "Dwyer".

**Reinitialize Device Service (DM-RD-B)**

This device supports the Reinitialize Device Service BIBB. The supported device states are COLDSTART and WARMSTART. All other states return error. This device is configured with a password that must be provided to successfully execute this command. The password is "Dwyer".

**APPENDIX V: Setting BACnet Communication Protocol MS/TP MAC Address of Unit**

Switch Position	1	2	3	4	5	6	7	8
Address Value	128	64	32	16	8	4	2	1

**Table 8: Device objects**

The address assignment is determined by adding the values for each of the switches that are in the ON position. The transmitter comes from the factory with all of the DIP switches, except position 1, in the ON position as shown in Figure 10. The address of the transmitter would be 127 as it would be 64+32+16+8+4+2+1 = 127. Another example would be if the address desired was 008, the only DIP switch position in the ON position would be position 5 as shown in Figure 11.

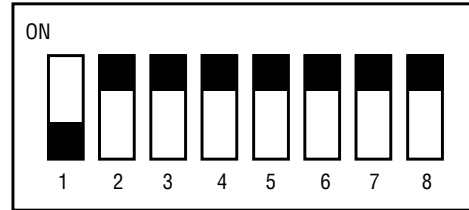

**Figure 10**

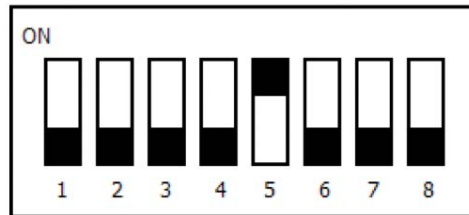

**Figure 11**

**NOTICE** Though the minimum possible address would be address 0 when all the DIP switch positions were set to OFF, and the maximum possible address would be address 255 when all of the DIP switches were set to ON, but the transmitter only has valid address from 0 to 127. Any address outside of this range will give an error code.

**APPENDIX VI: Property Tables**

Property	Default Value	Property Data Type	Access
Object Identifier	AI1	BACnetObjectIdentifier	Read
Object Name	Velocity FPM	CharacterString	Read
Object Type	ANALOG_INPUT (0)	BACnetObjectType	Read
Present Value	Current reading	Real	Read
Status Flags	0	BACnetStatusFlags	Read
Event State	NORMAL (0)	BACnetEventState	Read
Reliability	NO_FAULT_DETECTED(0)	BACnetReliability	Read
Out Of Service	FALSE (0)	Boolean	Read/Write
Units	Feet-per-minute (77)	BACnetEngineeringUnits	Read

**Table 9: Analog input – Velocity FPM**

Property	Default Value	Property Data Type	Access
Object Identifier	607xxx	BACnetObjectIdentifier	Read/Write
Object Name	"AVLV Velocity"	CharacterString(32)	Read/Write
ObjectType	DEVICE(8)	BACnetObjectType	Read
System Status	Operational(0)	BACnetDeviceStatus	Read
Vendor Name	"Dwyer Instruments, LLC"	CharacterString	Read
Vendor Identifier	607	Unsigned	Read
Model Name	"AVLV"	CharacterString	Read
Firmware Revision	"1.0.14"	CharacterString	Read
Application Software Version	"3.1.2.0"	CharacterString	Read
Location		CharacterString(32)	Read/Write
Description	"Thermal Anemometer"	CharacterString(32)	Read/Write
Protocol Version	1	Unsigned	Read
Protocol Revision	12	Unsigned	Read
Protocol Services Supported	See PICS	BACnetServicesSupported	Read
Protocol Object Types Supported	See Table 7	BACnetObjectTypesSupported	Read
Object List	See Table 7	BACnetArray	Read
Maximum APDU Length Accepted	128	Unsigned	Read
Segmentation Supported	NO_SEGMENTATION (3)	BACnetSegmentation	Read
APDU Timeout	0	Unsigned	Read
Number of APDU Retries	0	Unsigned	Read
Max Master	127	Unsigned	Read/Write
Max Info Frames	1	Unsigned	Read/Write
Device Address Binding	Empty	BACnetAddressBinding	Read
Database Revision	0	Unsigned	Read
Serial Number (1000)		CharacterString	Read
Sensor Serial Number (1001)		CharacterString	Read

Table 10: Device objects

Property	Default Value	Property Data Type	Access
Object Identifier	AI2	BACnetObjectIdentifier	Read
Object Name	Velocity MPS	CharacterString	Read
Object Type	ANALOG_INPUT (0)	BACnetObjectType	Read
Present Value	Current reading	Real	Read
Status Flags	0	BACnetStatusFlags	Read
Event State	NORMAL (0)	BACnetEventState	Read
Reliability	NO_FAULT_DETECTED(0)	BACnetReliability	Read
Out Of Service	FALSE (0)	Boolean	Read/Write
Units	Meters-per-second (74)	BACnetEngineeringUnits	Read

Table 11: Analog input – Velocity MPS

Property	Default Value	Property Data Type	Access
Object Identifier	AI3	BACnetObjectIdentifier	Read
Object Name	Temperature F	CharacterString	Read
Object Type	ANALOG_INPUT (0)	BACnetObjectType	Read
Present Value	Current reading	Real	Read
Status Flags	0	BACnetStatusFlags	Read
Event State	NORMAL (0)	BACnetEventState	Read
Reliability	NO_FAULT_DETECTED(0)	BACnetReliability	Read
Out Of Service	FALSE (0)	Boolean	Read/Write
Units	Degrees-fahrenheit (64)	BACnetEngineeringUnits	Read

Table 12: Analog input – Temperature F

Property	Default Value	Property Data Type	Access
Object Identifier	AI4	BACnetObjectIdentifier	Read
Object Name	Temperature C	CharacterString	Read
Object Type	ANALOG_INPUT (0)	BACnetObjectType	Read
Present Value	Current reading	Real	Read
Status Flags	0	BACnetStatusFlags	Read
Event State	NORMAL (0)	BACnetEventState	Read
Reliability	NO_FAULT_DETECTED(0)	BACnetReliability	Read
Out Of Service	FALSE (0)	Boolean	Read/Write
Units	Degrees-celsius (206)	BACnetEngineeringUnits	Read

Table 13: Analog input – Temperature C

Property	Default Value	Property Data Type	Access
Object Identifier	AV1	BACnetObjectIdentifier	Read
Object Name	Flow CFM	CharacterString	Read
Object Type	ANALOG_VALUE (2)	BACnetObjectType	Read
Present Value	Current reading	Real	Read
Status Flags	0	BACnetStatusFlags	Read
Event State	NORMAL (0)	BACnetEventState	Read
Reliability	NO_FAULT_DETECTED(0)	BACnetReliability	Read
Out Of Service	FALSE (0)	Boolean	Read/Write
Units	Cubic-feet-per-minute (84)	BACnetEngineeringUnits	Read

Table 14: Analog value – Flow CFM

Property	Default Value	Property Data Type	Access
Object Identifier	AV2	BACnetObjectIdentifier	Read
Object Name	Flow CMH	CharacterString	Read
Object Type	ANALOG_VALUE (2)	BACnetObjectType	Read
Present Value	Current reading	Real	Read
Status Flags	0	BACnetStatusFlags	Read
Event State	NORMAL (0)	BACnetEventState	Read
Reliability	NO_FAULT_DETECTED(0)	BACnetReliability	Read
Out Of Service	FALSE (0)	Boolean	Read/Write
Units	Cubic-meters-per-hour (135)	BACnetEngineeringUnits	Read

Table 15: Analog value – Flow CMH

Property	Default Value	Property Data Type	Access
Object Identifier	AV3	BACnetObjectIdentifier	Read
Object Name	Flow Area SqFt	CharacterString	Read
Object Type	ANALOG_VALUE (2)	BACnetObjectType	Read
Present Value	1	Real	Read
Status Flags	0	BACnetStatusFlags	Read
Event State	NORMAL (0)	BACnetEventState	Read
Reliability	NO_FAULT_DETECTED(0)	BACnetReliability	Read
Out Of Service	FALSE (0)	Boolean	Read/Write
Units	Square-feet (1)	BACnetEngineeringUnits	Read

Table 16: Analog value – Flow area SqFt

Property	Default Value	Property Data Type	Access
Object Identifier	AV4	BACnetObjectIdentifier	Read
Object Name	Flow Area SqM	CharacterString	Read
Object Type	ANALOG_VALUE (2)	BACnetObjectType	Read
Present Value	1	Real	Read/Write
Status Flags	0	BACnetStatusFlags	Read
Event State	NORMAL (0)	BACnetEventState	Read
Reliability	NO_FAULT_DETECTED(0)	BACnetReliability	Read
Out Of Service	FALSE (0)	Boolean	Read/Write
Units	Square-meters (0)	BACnetEngineeringUnits	Read

Table 17: Analog value – Flow area SqM

Property	Default Value	Property Data Type	Access
Object Identifier	BV1	BACnetObjectIdentifier	Read
Object Name	Zero	CharacterString	Read
Object Type	BINARY_VALUE (5)	BACnetObjectType	Read
Present Value	ACTIVE (1)	BACnetBinaryPV	Read/Write
Status Flags	0	BACnetStatusFlags	Read
Event State	NORMAL (0)	BACnetEventState	Read
Reliability	NO_FAULT_DETECTED(0)	BACnetReliability	Read
Out Of Service	FALSE (0)	Boolean	Read/Write

Table 18: Binary value - Zero

Property	Default Value	Property Data Type	Access
Object Identifier	BV2	BACnetObjectIdentifier	Read
Object Name	Span	CharacterString	Read
Object Type	BINARY_VALUE (5)	BACnetObjectType	Read
Present Value	INACTIVE (0)	BACnetBinaryPV	Read/Write
Status Flags	0	BACnetStatusFlags	Read
Event State	NORMAL (0)	BACnetEventState	Read
Reliability	NO_FAULT_DETECTED(0)	BACnetReliability	Read
Out Of Service	FALSE (0)	Boolean	Read/Write

Table 19: Binary value - Span

Property	Default Value	Property Data Type	Access
Object Identifier	BV3	BACnetObjectIdentifier	Read
Object Name	Restore Factory Pressure Values	CharacterString	Read
Object Type	BINARY_VALUE (5)	BACnetObjectType	Read
Present Value	INACTIVE (0)	BACnetBinaryPV	Read/Write
Status Flags	0	BACnetStatusFlags	Read
Event State	NORMAL (0)	BACnetEventState	Read
Reliability	NO_FAULT_DETECTED(0)	BACnetReliability	Read
Out Of Service	FALSE (0)	Boolean	Read/Write

Table 20: Binary value - Restore factory default values



### APPENDIX III: Menu Flow Chart

#### BUTTON PRESS LEGEND

- ZERO = PRESS ZERO BUTTON
- SPAN = PRESS SPAN BUTTON
- ZERO = PRESS AND HOLD ZERO BUTTON
- SPAN = PRESS AND HOLD SPAN BUTTON
- ZERO  
SPAN = PRESS AND HOLD ZERO AND SPAN BUTTONS

#### MENU CONVENTIONS

##### IN HOME POSITION:

- ZERO CALIBRATE UNIT TO ZERO PRESSURE.
- SPAN CALIBRATE UNIT TO SPAN PRESSURE.

  — DISPLAY IS NOT NECESSARY

- ZERO  
SPAN ENTER MENU DISPLAY

##### IN MENU DISPLAY:

- SPAN SEQUENCES TO NEXT MAIN MENU ITEM, AND IF A MENU ITEM IS CHANGED TEMPORARILY SAVES THE SELECTION
- ZERO SEQUENCES THROUGH SUB MENU SELECTIONS OR INCREMENTS DIGITS
- SPAN SEQUENCE TO NEXT DIGIT. ACTIVE DIGIT WILL BLINK. 3 = BLINKING DIGIT

### Averaging Menu

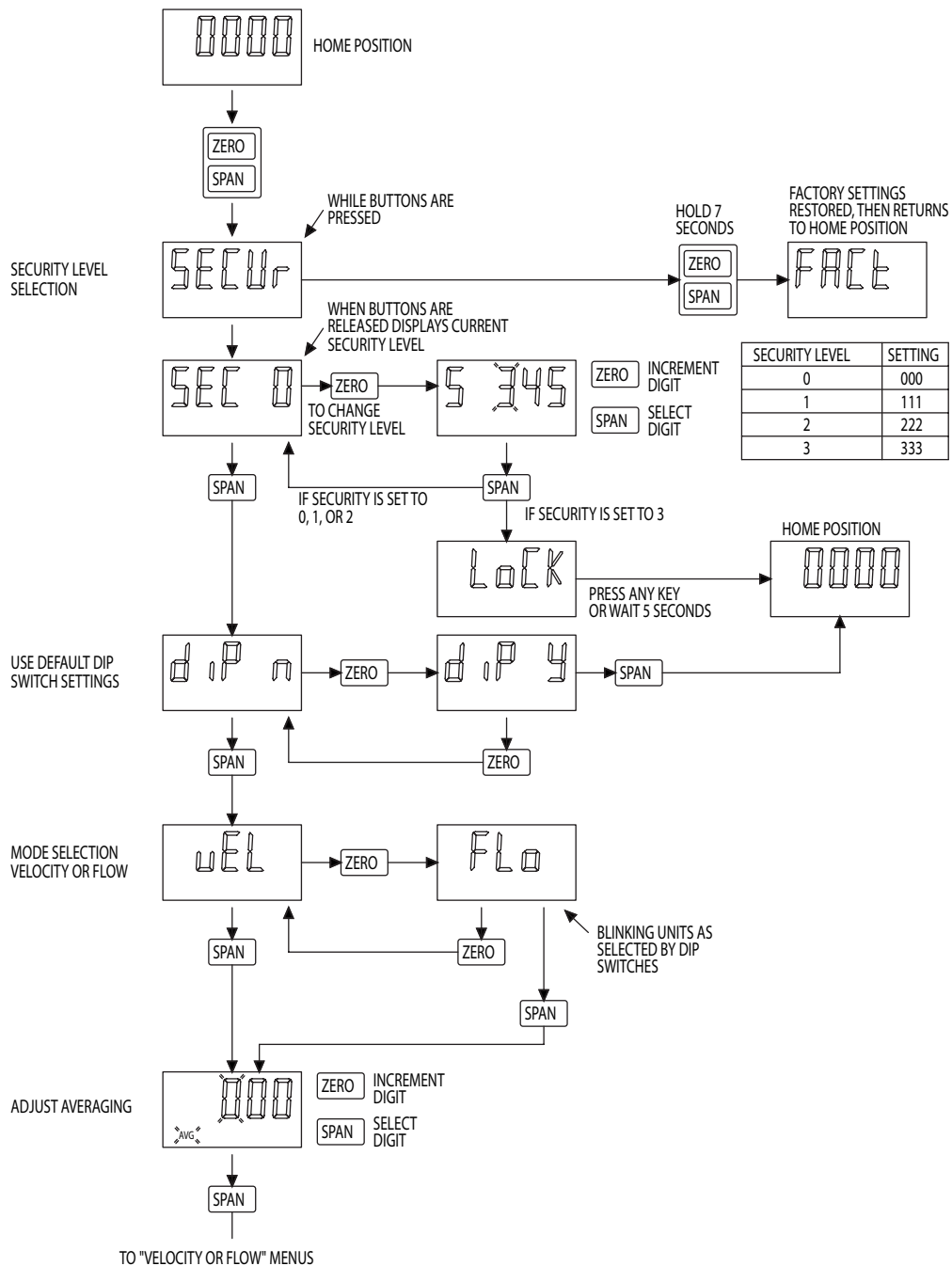

# Velocity Mode Menu

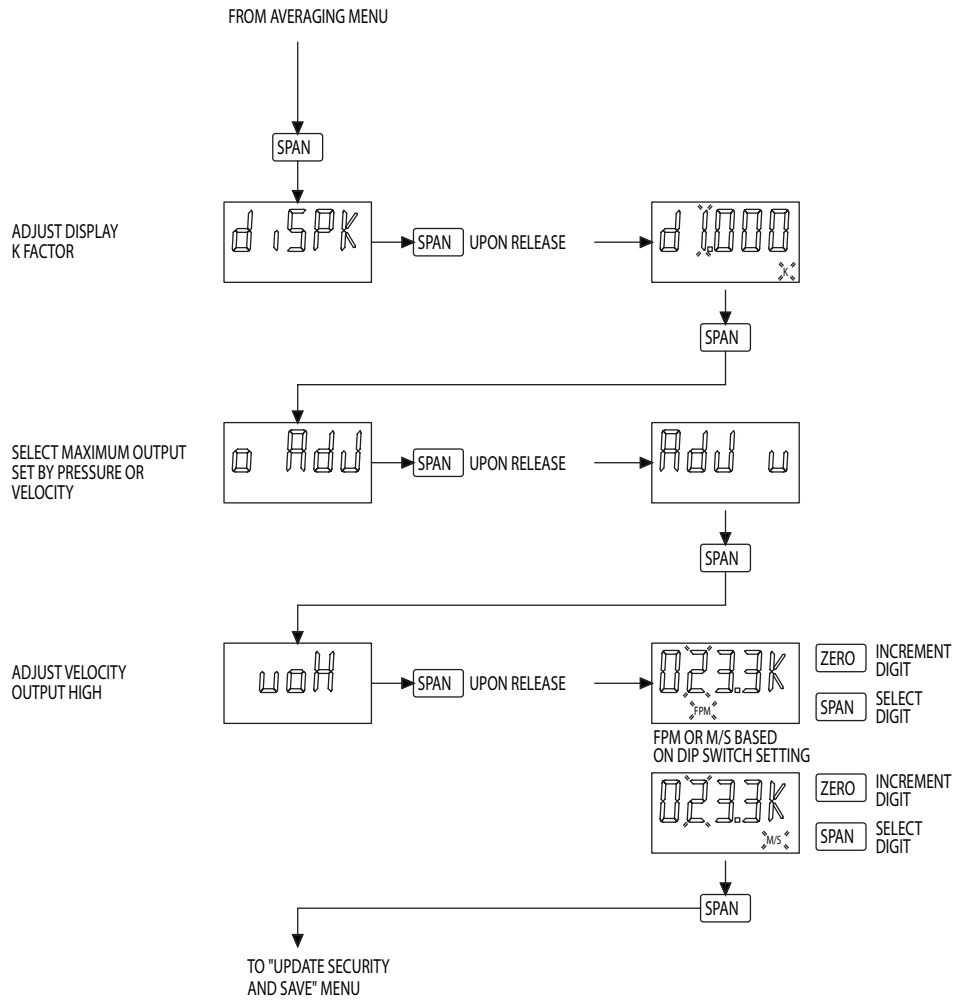

# Flow Mode Menu

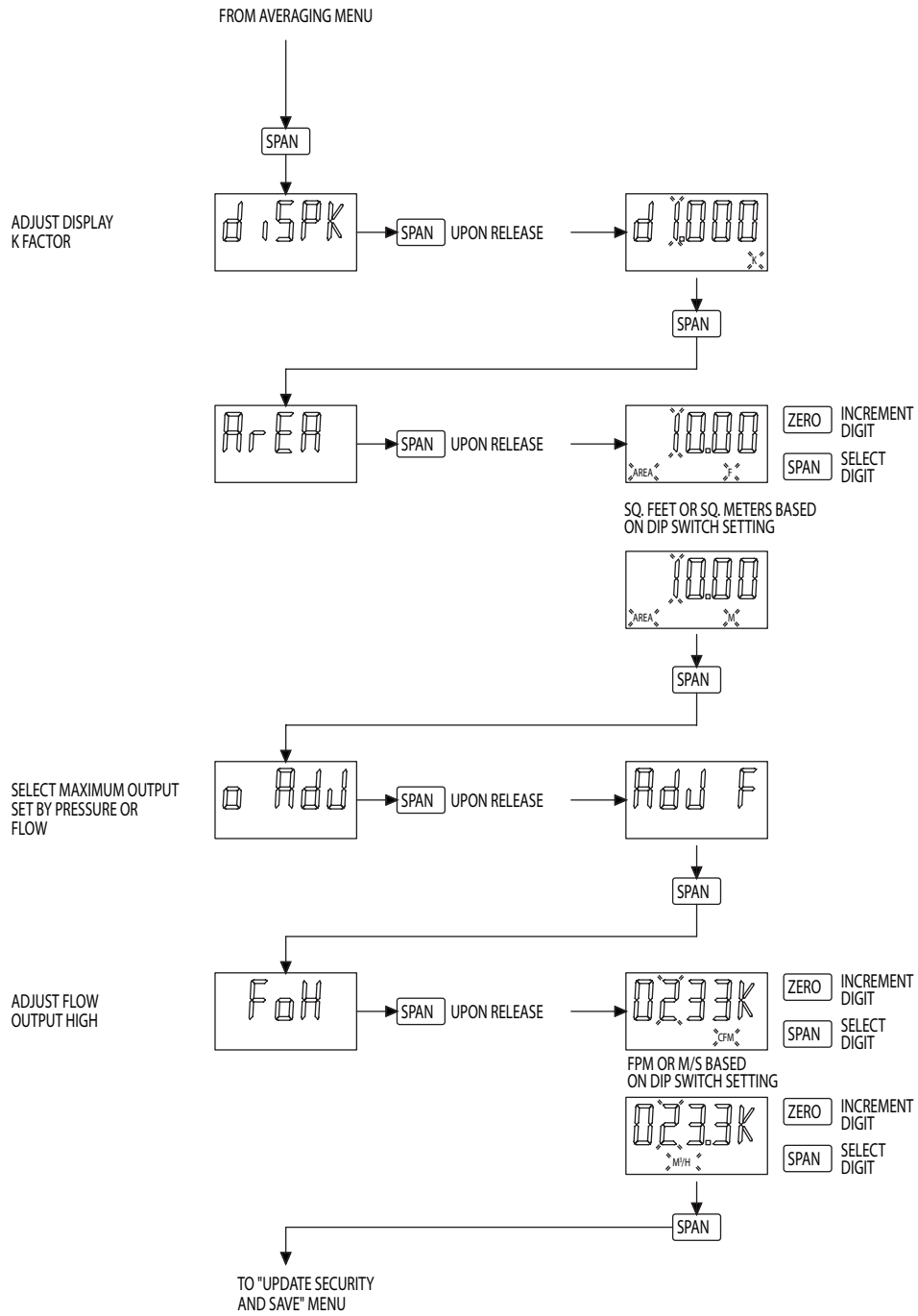

## Security Menu

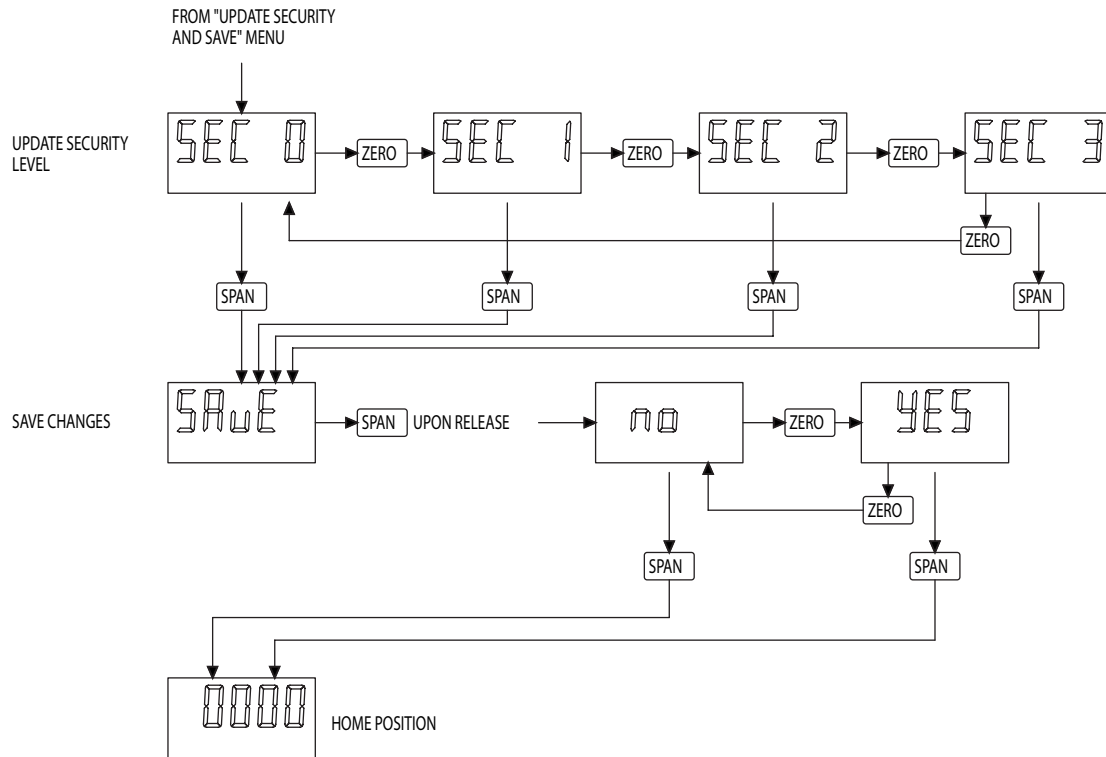

Modbus® is a registered trademark of Schneider Electric USA, Inc.