

STABILISENSE™ CRITICAL ROOM PRESSURE MONITOR

Room Status Indication, Magnehelic® Gage Size

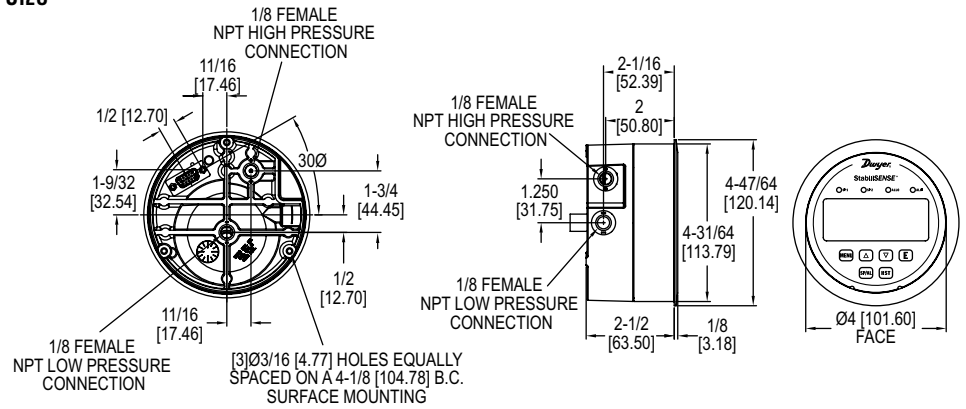

The Series RPMC StabilisENSE™ Critical Room Pressure Monitor is designed for critical low differential pressure applications that require stringent pressure monitoring and alarming. The Series RPMC can be configured to monitor positive or negative pressure in protected environments and clean manufacturing areas. The RPMC is a complete system which enables access to pressure, security, calibration, and alarm setup. The RPMC StabilisENSE™ critical room pressure monitor has a brushed stainless steel bezel that allows for easy cleaning.

The RPMC StabilisENSE™ critical room pressure monitor has built-in status indication LEDs that will appear green when within the user-defined pressure set range and will appear orange when outside of the pressure set range. 2 SPDT independent control relays with adjustable deadbands are also provided along with a 4-20 mA process output.

BENEFITS/FEATURES

- Long term stable pressure measurements
- 2 SPDT relays allow for local alarming and alarming to control system
- Automatic or manual alarm reset
- Visual LED alarms provide immediate local alert allowing corrective action to be taken quicker to eliminate the problem from becoming widespread
- Stores peak and valley process readings
- Same installation diameter as Magnehelic® gage which simplifies field upgrade to RPMC StabilisENSE™ critical room pressure monitor
- Password protected setup menu ensures no errors by untrained personnel

APPLICATIONS

- Clean manufacturing areas
- Semiconductor manufacturing
- Pharmaceutical
- Clean rooms
- Research labs
- Vivariums

SPECIFICATIONS

Service: Air and non-combustible, compatible gases.
Measurement Technology: Capacitance cell.
Wetted Materials: Consult factory.
Housing Material: Die cast aluminum case and SS bezel.
Accuracy: ±0.25% RSS (includes non-linearity: ±0.24%, hysteresis: ±0.05% and non-repeatability: ±0.05%), or ±0.5% RSS (includes non-linearity: ±0.49%, hysteresis: ±0.05% and non-repeatability: ±0.05%).
Pressure Limits: 2 psig.
Temperature Limits: 32 to 140°F (0 to 60°C).
Compensated Temperature Limits: 32 to 140°F (0 to 60°C).
Thermal Effects: 0.030%/°F (0.050/°C) from 77°F (25°C).
Power Requirements: 12-28 VDC, 12-28 VAC 50 to 400 Hz.
Power Consumption: 3 VA max.
Output Signal: 4-20 mA DC into 900 Ω max.
Zero and Span Adjustments: Accessible via menus.
Response Time: 8 ms.
Display: Backlit 4 digit LCD 0.4" height LED indicators for set point and alarm status.
Electrical Connections: 15 pin male high density D-sub connection. 18" (46 cm) cable with 10 conductors included.
Process Connections: 1/8" female NPT. Side or back connections.
Mounting Orientation: Mount unit in vertical plane. Size: 4-3/4" (120.7 mm) OD x 2-21/32 (67.5 mm).
Weight: 1.90 lb (862 g).
Compliance: CE.

SWITCH SPECIFICATIONS
Switch Type: 2 SPDT relays.
Electrical Rating: 1 A @ 30 VAC/VDC.
Set Point Adjustment: Adjustable via keypad on face.

MODEL CHART	
Model	Description
RPMC-A-002	StabilisENSE™ critical room pressure monitor, 0.25% accuracy, 0-0.25 in w.c. range
RPMC-A-003	StabilisENSE™ critical room pressure monitor, 0.25% accuracy, 0-0.5 in w.c. range
RPMC-A-013	StabilisENSE™ critical room pressure monitor, 0.25% accuracy, -0.25-0-0.25 in w.c. range
RPMC-A-014	StabilisENSE™ critical room pressure monitor, 0.25% accuracy, -0.5 0-0.5 in w.c. range
RPMC-B-002	StabilisENSE™ critical room pressure monitor, 0.5% accuracy, 0-0.25 in w.c. range
RPMC-B-003	StabilisENSE™ critical room pressure monitor, 0.5% accuracy, 0-0.5 in w.c. range
RPMC-B-013	StabilisENSE™ critical room pressure monitor, 0.5% accuracy, -0.25-0-0.25 in w.c. range
RPMC-B-014	StabilisENSE™ critical room pressure monitor, 0.5% accuracy, -0.5 0-0.5 in w.c. range

OPTIONS	
Model	Description
-FC	Factory calibration certificate
-NIST	NIST traceable calibration certificate

ACCESSORIES	
Model	Description
A-220	Clear flexible vinyl tubing is easily inspected, and is therefore best for test applications where a possibility of fluid entering the tubing exists. 3/16" ID x 5/16" OD, lengths to 500"; 45 psi maximum pressure @ 73°F
A-285	Remote alarm annunciator with visible/audible alarm and acknowledge switch
A-299	Mounting bracket flush mount Magnehelic® gage in bracket. Bracket is then surface mounted. Steel with gray hammertone epoxy finish. 6.3" x 7.7" x 4.0", 1.30 lb.
A-300	Flat aluminum bracket for flush mounting
A-417A	Static pressure pickup. For use in clean rooms, 60 micron filter picks up static pressure. SS wall plate fits 2" x 4" electrical box. Sealed with foam gasket, screws included. Barbed brass fitting holds 1/8" to 3/16" ID tubing
A-418A	Static pressure pickup. Room mount with delta style plastic enclosure fits 2" x 4" electrical box. Fine mesh screen hides static pressure pickup port. Clean connection to 1/8" to 3/16" I.D. tubing and pressure sensor. Sealed with foam gasket, screws included
A-465	Flush mount space pressure sensor, white plastic